

USING THIS MANUAL



POWERCUT 1600

Plasmarc Cutting Package



TABLE OF CONTENTS

SAFETY

INTRODUCTION

SPECIFICATIONS

MAIN SCHEMATIC

WIRING DIAGRAMS

REPLACEMENT PARTS

REMOVAL/
REPLACEMENT
PROCEDURES

MECHANIZED
CONVERSION

GENERAL

Service Manual

This manual provides service / troubleshooting instructions for PC1600 consoles beginning with Serial NumberPCJ912015

Manual # 0558008016- Rev. 1

3/2009

PART NO	DESCRIPTION
0558007230	PC1600 230/460V Console
0558007230F	PC1600 230/460V BL Console
0558007237	PC1600 575V BL Console
0558007636	PC1600 400V Console
0558007234	PC1600 400V CE Console
0558007883	PC1600 MECH 230/460V
0558007884	PC1600 MECH 400V CE
0558008323	PC1600 460V Console

(BL = Bilingual)

CAUTION

This Service Manual is for experienced technicians. If you are not fully familiar with the principles of operation and safe practices for arc welding and cutting equipment, we urge you to read our booklet, "Precautions and Safe Practices for Arc Welding, Cutting, and Gouging," Form 52-529. Do NOT permit untrained persons to install, operate, or maintain this equipment. Do NOT attempt to install or operate this equipment until you have read and fully understand these instructions. If you do not fully understand these instructions, contact your supplier for further information. Be sure to read the Safety Precautions before installing or operating this equipment.

USER RESPONSIBILITY

This equipment will perform in conformity with the description thereof contained in this manual and accompanying labels and/or inserts when installed, operated, maintained and repaired in accordance with the instructions provided. This equipment must be checked periodically. Malfunctioning or poorly maintained equipment should not be used. Parts that are broken, missing, worn, distorted or contaminated should be replaced immediately. Should such repair or replacement become necessary, the manufacturer recommends that a telephone or written request for service advice be made to the Authorized Distributor from whom it was purchased.

This equipment or any of its parts should not be altered without the prior written approval of the manufacturer. The user of this equipment shall have the sole responsibility for any malfunction which results from improper use, faulty maintenance, damage, improper repair or alteration by anyone other than the manufacturer or a service facility designated by the manufacturer.

SECTIONS

SAFETY		1
INTRODUCTION		2
SPECIFICATIONS		3
DESCRIPTION OF OPERATION		4
SCHEMATIC SECTION MAP		4.0
MAIN POWER SWITCH	S1	4.1
CONTROL TRANSFORMER	T2	4.2
INPUT BRIDGE	BR1	4.3
CONTACTOR	K1	4.4
VOLTAGE SELECTOR SWITCH	SW2	4.5
MAIN TRANSFORMER	T1	4.6
OUTPUT DIODES		4.7
PLASMA CONTROL / DISPLAY BOARD	PCB1	4.8
FILTERS	L1-L2	4.9
POWER BOARD	PCB2	4.10
POWER DRIVER	PCB3 - PCB4	4.11
THERMAL SWITCH	TS1	4.12
PILOT ARC CIRCUIT		4.13
HELP CODES		4.14
PRESSURE TRANSDUCER	PT1	4.15
EMC FILTER (CE UNITS)	PCB7	4.16
SOLENOID	SOL1	4.17
REMOTE	PCB6	4.18
TORCH	PT38	4.19
WIRING DIAGRAMS		5
REPLACEMENT PARTS		6
MECHANIZED CONVERSION		7
ERRORS		8
GENERAL INFORMATION		10

TABLE OF CONTENTS

Section / Title	Page
2.0 Introduction	12
3.0 Power Specifications	13
3.0 Specifications	13
3.1 Power Up Sequence	14
3.2 Parts In Place Check	14
3.3 Power Up Sequence	14
3.4 Machine Operation Flowchart	15
3.5 Component Locator	16
4.0 Machine Testing / Troubleshooting / Service	17
4.0 Schematic Section Map 230/460V- 0558007542	17
4.0 Schematic Section Map 400V/400V CE- 0558007546	18
4.0 Schematic Section Map 575V- 0558007544	19
4.1 Main Power Switch S1 (36107)	20
4.2 Control Transformer T2 (0558007188/0558008546)	21
4.3 Input Bridge (0558007068 / 0558007077)	26
4.4 Contactor K1 (950247 / 0558002576)	28
4.5 Voltage Selector Switch SW2 (0558007183)	29
4.6 Main Transformer T1 (0558007189 / 0558007190 / 0558007191)	30
4.7 Output Diodes D101, D102 – (951185)	32
4.8 PCB1 Control/Display Board (0558038317)	33
4.8.1 PCB1_Bias Supplies (0558038317)	35
4.8.2 PCB1_Display (0558038317)	36
4.8.3 PCB1_Error Amp / Current Reference (0558038317)	37
4.8.4 PCB1_Mode Switches (0558038317)	38
4.8.5 PCB1_Protection Circuit (0558038317)	39
4.8.6 PCB1_Gas Test Operate Switch (0558038317)	40
4.8.7 PCB1_PWM Circuit (0558038317)	41
4.8.8 PCB1_RS232 Input (0558038317)	42
4.8.9 PCB1_Current Reference (0558038317)	43
4.8.10 PCB1_Programming Port(0558038317)	44
4.8.11 PCB1_Thermal Sensing Circuit (0558038317)	44
4.8.12 PCB1_I/O (0558038317)	46
4.8.13 PCB1_Microcontroller U5 (0558038317)	46
4.9 Input Inductor L1 (0558007149/ / 0558007151)	50
4.9.1 Output Inductor (0558007152)	51
4.10 Power PC Board (0558038315)	52
4.10.1 Power PC Board Schematic (0558038315)	53
4.10.2 Power PC Board Schematic 2 (0558038315)	54
4.10.3 Power Board_PCB2 Bias Supply Circuit (0558038315)	55
4.10.4 Power PC Board Over Current Protection (0558038315)	57
4.10.5 Power PC Board_Pilot Arc / IGBT Driver Circuit (0558038315)	58
4.10.6 Power PC Board Single Phase Detection (0558038315)	59
4.10.7 Power Board_PCB2 Control Relays (0558038315)	60
4.10.7 Power Board_PCB2 Control Relays (0558038315)	61
4.10.8 Power Board_PCB2 Voltage Selection Circuit (0558038315)	62
4.10.9 Power Board_PCB2 CNC Interface (0558038315)	64

TABLE OF CONTENTS

Section / Title	Page
4.10.10 Power Board_PCB2 Output Circuit (0558038315)	65
4.10.11 Power Board_PCB2 V-Arc Circuit (0558038315)	66
4.10.12 Power Board_PCB2 Inrush Circuit (0558038315)	67
4.10.13 Power Board_PCB2 Pressure Transducer (0558038315)	68
4.10.14 Power Board_PCB2 Relay Boost Circuit (0558038315)	69
4.10.15 Power Board_PCB2 Torch Trigger Circuit (0558038315)	70
4.10.16 Buss Supply/IGBT	71
4.10.17 Power Board_PCB2 Microcontroller Circuit (0558038315)	76
4.10.18 Power Board_PCB2 Thermal Switch Circuit (0558038315)	77
4.10.19 Power Board_PCB2 Gate Driver Circuit (0558038315)	78
4.10.20 Power Board_PCB2 RS232 Interface (0558038315)	79
4.10.21 Power Board_PCB2 Layout (0558038315)	80
4.11 Power Driver_PCB3 / PCB4 (0558038335)	84
4.12 Thermal Switch TS1 (951085)	87
4.13 Pilot Arc Driver Board PCB5 (05580038344)	89
4.14 Help Codes	91
4.15 Pressure Transducer (0558006148)	92
4.16 EMC Filter 50A_PCB7 (CE Units_ 0455803880)	94
4.17 Solenoid SOL1 (0558007072)	95
4.18 Remote_PCB6 (0558038337)	96
4.19 PT38 Plasma Torch	99
5.0 Wiring Diagrams	106
5.1 Wiring Diagram 230/460 Volt (0558007543)	106
5.2 Wiring Diagram 400/400V CE (0558007547)	109
5.3 Wiring Diagram 575V (0558007545)	112
5.3 Wiring Diagram 575V (0558007545)	114
6.0 Replacement Parts	116
6.1 General	116
6.2 Ordering	116
6.3 Front (0558007540)	120
6.3 Fan Kit (0558008454)	120
6.3 Right Interior View (0558007540)	122
6.3 Top (0558007540)	124
6.3 Left Inside (0558007540)	126
6.3 Left Inside2 (0558007540)	128
6.3 Rear View (0558007540)	130
6.3 Front/Rear Isometric Views (0558007540)	132
6.4 Model Specific Parts BOM	134
6.4 Model Specific Parts BOM	136
7.0 MECHANIZED CONVERSION	137
8.0 ERRORS	145
8.0 Error 13	145
8.1 Error 15	147
9.0 Program Changes	148
10.0 General Information	149
Index	166



WARNING: These Safety Precautions are for your protection. They summarize precautionary information from the references listed in Additional Safety Information section. Before performing any installation or operating procedures, be sure to read and follow the safety precautions listed below as well as all other manuals, material safety data sheets, labels, etc. Failure to observe Safety Precautions can result in injury or death.

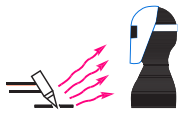

PROTECT YOURSELF AND OTHERS -- Some welding, cutting, and gouging processes are noisy and require ear protection. The arc, like the sun, emits ultraviolet (UV) and other radiation and can injure skin and eyes. Hot metal can cause burns. Training in the proper use of the processes and equipment is essential to prevent accidents. Therefore:

1. Always wear safety glasses with side shields in any work area, even if welding helmets, face shields, and goggles are also required.
2. Use a face shield fitted with the correct filter and cover plates to protect your eyes, face, neck, and ears from sparks and rays of the arc when operating or observing operations. Warn bystanders not to watch the arc and not to expose themselves to the rays of the electric-arc or hot metal.
3. Wear flameproof gauntlet type gloves, heavy long-sleeve shirt, cuffless trousers, high-topped shoes, and a welding helmet or cap for hair protection, to protect against arc rays and hot sparks or hot metal. A flameproof apron may also be desirable as protection against radiated heat and sparks.
4. Hot sparks or metal can lodge in rolled up sleeves, trouser cuffs, or pockets. Sleeves and collars should be kept buttoned, and open pockets eliminated from the front of clothing.
5. Protect other personnel from arc rays and hot sparks with a suitable non-flammable partition or curtains.
6. Use goggles over safety glasses when chipping slag or grinding. Chipped slag may be hot and can fly far. Bystanders should also wear goggles over safety glasses.



FIRES AND EXPLOSIONS -- Heat from flames and arcs can start fires. Hot slag or sparks can also cause fires and explosions. Therefore:

1. Remove all combustible materials well away from the work area or cover the materials with a protective non-flammable covering. Combustible materials include wood, cloth, sawdust, liquid and gas fuels, solvents, paints and coatings, paper, etc.
2. Hot sparks or hot metal can fall through cracks or crevices in floors or wall openings and cause a hidden smoldering fire or fires on the floor below. Make certain that such openings are protected from hot sparks and metal."
3. Do not weld, cut or perform other hot work until the workpiece has been completely cleaned so that there are no substances on the workpiece which might produce flammable or toxic vapors. Do not do hot work on closed containers. They may explode.
4. Have fire extinguishing equipment handy for instant use, such as a garden hose, water pail, sand bucket, or portable fire extinguisher. Be sure you are trained in its use.
5. Do not use equipment beyond its ratings. For example, overloaded welding cable can overheat and create a fire hazard.
6. After completing operations, inspect the work area to make certain there are no hot sparks or hot metal which could cause a later fire. Use fire watchers when necessary.
7. For additional information, refer to NFPA Standard 51B, "Fire Prevention in Use of Cutting and Welding Processes", available from the National Fire Protection Association, Batterymarch Park, Quincy, MA 02269.

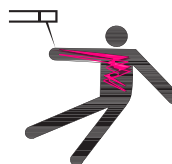

ELECTRICAL SHOCK -- Contact with live electrical parts and ground can cause severe injury or death. **DO NOT** use AC welding current in damp areas, if movement is con-

fined, or if there is danger of falling.

1. Be sure the power source frame (chassis) is connected to the ground system of the input power.
2. Connect the workpiece to a good electrical ground.
3. Connect the work cable to the workpiece. A poor or missing connection can expose you or others to a fatal shock.
4. Use well-maintained equipment. Replace worn or damaged cables.
5. Keep everything dry, including clothing, work area, cables, torch/Piston, and power source.
6. Make sure that all parts of your body are insulated from work and from ground.
7. Do not stand directly on metal or the earth while working in tight quarters or a damp area; stand on dry boards or an insulating platform and wear rubber-soled shoes.
8. Put on dry, hole-free gloves before turning on the power.
9. Turn off the power before removing your gloves.
10. Refer to ANSI/ASC Standard Z49.1 (listed on next page) for specific grounding recommendations. Do not mistake the work lead for a ground cable.



ELECTRIC AND MAGNETIC FIELDS — May be dangerous. Electric current flowing through any conductor causes localized Electric and Magnetic Fields (EMF). Welding and cutting current creates EMF around welding cables and welding machines. Therefore:

1. Welders having pacemakers should consult their physician before welding. EMF may interfere with some pacemakers.
2. Exposure to EMF may have other health effects which are unknown.
3. Welders should use the following procedures to minimize exposure to EMF:
 - A. Route the electrode and work cables together. Secure them with tape when possible.
 - B. Never coil the torch or work cable around your body.
 - C. Do not place your body between the torch and work cables. Route cables on the same side of your body.
 - D. Connect the work cable to the workpiece as close as possible to the area being welded.
 - E. Keep welding power source and cables as far away from your body as possible.



FUMES AND GASES -- Fumes and gases, can cause discomfort or harm, particularly in confined spaces. Do not breathe fumes and gases. Shielding gases can cause asphyxiation. Therefore:

1. Always provide adequate ventilation in the work area by natural or mechanical means. Do not weld, cut, or gouge on materials such as galvanized steel, stainless steel, copper, zinc, lead, beryllium, or cadmium unless positive mechanical ventilation is provided. Do not breathe fumes from these materials.
2. Do not operate near degreasing and spraying operations. The heat or arc rays can react with chlorinated hydrocarbon vapors to form phosgene, a highly toxic gas, and other irritant gases.

3. If you develop momentary eye, nose, or throat irritation while operating, this is an indication that ventilation is not adequate. Stop work and take necessary steps to improve ventilation in the work area. Do not continue to operate if physical discomfort persists.

4. Refer to ANSI/ASC Standard Z49.1 (see listing below) for specific ventilation recommendations.

5. **WARNING:** This product, when used for welding or cutting, produces fumes or gases which contain chemicals known to the State of California to cause birth defects and, in some cases, cancer. (California Health & Safety Code §25249.5 et seq.)

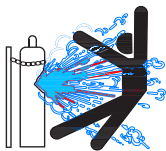

CYLINDER HANDLING -- Cylinders, if mishandled, can rupture and violently release gas. Sudden rupture of cylinder, valve, or relief device can injure or kill. Therefore:

1. Use the proper gas for the process and use the proper pressure reducing regulator designed to operate from the compressed gas cylinder. Do not use adaptors. Maintain hoses and fittings in good condition. Follow manufacturer's operating instructions for mounting regulator to a compressed gas cylinder.

2. Always secure cylinders in an upright position by chain or strap to suitable hand trucks, undercarriages, benches, walls, post, or racks. Never secure cylinders to work tables or fixtures where they may become part of an electrical circuit.

3. When not in use, keep cylinder valves closed. Have valve protection cap in place if regulator is not connected. Secure and move cylinders by using suitable hand trucks. Avoid rough handling of cylinders.

4. Locate cylinders away from heat, sparks, and flames. Never strike an arc on a cylinder.

5. For additional information, refer to CGA

Standard P-1, "Precautions for Safe Handling of Compressed Gases in Cylinders", which is available from Compressed Gas Association, 1235 Jefferson Davis Highway, Arlington, VA 22202.



EQUIPMENT MAINTENANCE -- Faulty or improperly maintained equipment can cause injury or death. Therefore:

1. Always have qualified personnel perform the installation, troubleshooting, and maintenance work. Do not perform any electrical work unless you are qualified to perform such work.

2. Before performing any maintenance work inside a power source, disconnect the power source from the incoming electrical power.

3. Maintain cables, grounding wire, connections, power cord, and power supply in safe working order. Do not operate any equipment in faulty condition.

4. Do not abuse any equipment or accessories. Keep equipment away from heat sources such as furnaces, wet conditions such as water puddles, oil or grease, corrosive atmospheres and inclement weather.

5. Keep all safety devices and cabinet covers in position and in good repair.

6. Use equipment only for its intended purpose. Do not modify it in any manner.



ADDITIONAL SAFETY INFORMATION -- For more information on safe practices for electric arc welding and cutting equipment, ask your supplier for a copy of "Precautions and Safe Practices for Arc Welding, Cutting and Gouging", Form 52-529.

The following publications, which are available from the American Welding Society, 550 N.W. LeJuene Road, Miami, FL 33126, are recommended to you:

1. ANSI/ASC Z49.1 - "Safety in Welding and Cutting"
2. AWS C5.1 - "Recommended Practices for Plasma Arc Welding"
3. AWS C5.2 - "Recommended Practices for Plasma Arc Cutting"
4. AWS C5.3 - "Recommended Practices for Air Carbon Arc Gouging and Cutting"
5. AWS C5.5 - "Recommended Practices for Gas Tungsten Arc Welding"
6. AWS C5.6 - "Recommended Practices for Gas Metal Arc Welding"
7. AWS SP - "Safe Practices" - Reprint, Welding Handbook.
8. ANSI/AWS F4.1, "Recommended Safe Practices for Welding and Cutting of Containers That Have Held Hazardous Substances."

MEANING OF SYMBOLS - As used throughout this manual:



Means Attention! Be Alert! Your safety is involved.



Means immediate hazards which, if not avoided, will result in immediate, serious personal injury or loss of life.



Means potential hazards which could result in personal injury or loss of life.



Means hazards which could result in minor personal injury.



When plasma cutting stainless steel, you must comply with the OSHA standard to protect your employees from Hexavalent Chromium exposure.



Engineering control must be used to reduce exposures to safe levels (in compliance with the new PEL). The specific details of the standard are complex and may require the assistance of an occupational health professional to reach full compliance

For additional information about Hexavalent Chromium contact your occupational health professional and read the OSHA web page at <http://www.osha.gov/SLTC/hexavalentchromium/>



**CHROMIUM (VI)
Cr(VI)
HEXAVALENT CHROMIUM)**

Hexavalent Chromium Cr(VI) is a toxic chemical component within fume and dust particles created in a variety of processes, including plasma cutting of stainless steel.

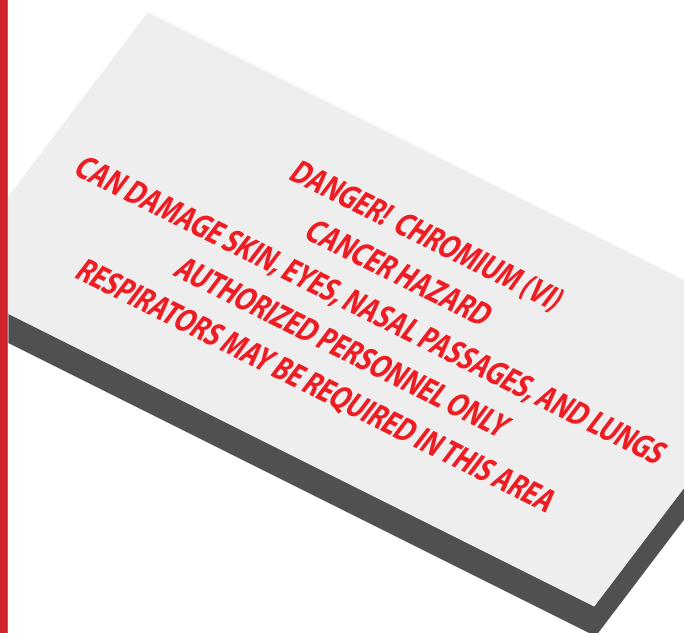

CANCER HAZARD; CAN DAMAGE SKIN, EYES, NASAL PASSAGES, AND LUNGS; AUTHORIZED PERSONNEL ONLY; RESPIRATORS MAY BE REQUIRED.

On February 28, 2006, the Occupational Safety and Health Agency (OSHA) published a revised standard to protect workers from the potential hazards of hexavalent chromium.

- Occupational exposure to hexavalent chromium (Cr(VI)) must be below the Permissible Exposure Limit (PEL) of 5 µg/m³ for an eight hour time weighted average.
- Workplace or job-specific monitoring must be done to establish areas of potential exposure and to quantify the potential exposure.
- Employees who may be exposed to levels of Cr(VI) at or above the new PEL must be informed and corrective measures implemented.
- Protective clothing and respiratory protection must be given to employees who have potential exposure.
- Medical surveillance of employees with potential exposure to Cr(VI) must be conducted.
- Areas of potential exposure to Cr(VI) must be indicated with warning signs containing the text shown at left.
- Engineering control must be used to reduce exposures to safe levels (in compliance with the new PEL). The specific details of the standard are complex and may require the assistance of an occupational health professional to reach full compliance

For additional information about Hexavalent Chromium contact your occupational health professional and read the OSHA web page at <http://www.osha.gov/SLTC/hexavalentchromium/>

2.0 Introduction

2.1 General

The Powercut 1600 is a compact plasma cutting system. As shipped, the system is fully assembled and ready to cut after being connected to input power and a source of compressed air (350 cfh @ 90 psi / 6.2 bar). The Powercut package uses the heavy-duty PT-38 (manual plasma) torch to deliver cutting power for selected materials up to 1.50 inch (38.1 mm) thick and severing selected materials up to 1.75 inch (45 mm) thick

2.2 Scope

The purpose of this manual is to provide qualified repair personnel with technical information which will assist in troubleshooting and repairing malfunctions.

2.3 Service Manual Format

The “machine operation” flow diagram starts the breakdown of the functionality of the PC-1600. Each of the major components is divided into sections, which are described in the pages that follow. Each section in the flow chart has a matching section on the main schematic and is applied to the description pages.

Each section starts with the schematic view with description, if the section includes a printed circuit PC board, it is followed by a PC board schematic, the layout of the board and then the component list for the board. Some PC boards will also have “mini descriptions” of selected circuits. This information is for troubleshooting purposes only, PC board repair is not recommended.

3.0**POWER SPECIFICATIONS****3.0 Specifications****Specifications: PowerCut -1600**

Cuts 1-1/2 in. (38 mm); severs 1-3/4 in. (45 mm)

1 ph. Input	208/230 vac, 1 ph, 50/60 Hz, 82/74 A
1 ph. Output	90 amps @ 40% duty cycle

3 ph. Input	208/230 vac, 3 ph, 50/60 Hz, 44/40 A
	230/460 vac, 3 ph, 50/60 Hz, 40/27 A
	400 vac, 3ph, 50/60 Hz, 26 A
	575 vac, 3ph, 50/60 Hz, 18 A
3 ph. Output	90 amps @ 60% duty cycle

Dimensions	W = 10.5" (267 mm)
	H = 15.0" (381 mm)
	D = 28.0" (711 mm)
Weight	90 lbs. (40.8 kg)
Air Requirements	350 cfh @ 80 psig (165 l/min @ 5.5 bars)

3.1 Power Up Sequence

Power up Sequence of Events

When the machine is turned on, a self diagnostic test is performed to determine the condition of the torch.

Sequence of events

The operator turns on the power switch

The Power Board PCB-1 determines if the input voltage is correct and connects input power.

The Control Board PCB-1 enables the In-rush circuit.

Power Board Relay K1 closes and pre-charges the buss supply.

The machine performs a Parts-in-Place check (PIP) and displays this on the front panel display. (See PIP test, below)

If the PIP test passes the machine is ready for operation.

3.2 Parts In Place Check

Parts-In-Place

The PC1600 performs a **Parts In Place** (PIP) check during initial power-up. The following steps are performed automatically each time power is applied:

- 1) Check For Air Pressure (**Error 5 invoked if No pressure**)
- 2) Open the gas valve
- 3) Close the Pilot Arc circuit
- 4) Pulse on the PWM - the unit looks for an open condition, an open electrode to nozzle. **Error 20 is invoked if there is current flow.**
- 5) Turns Off the Gas Valve
- 6) Pulses on the PWM again.
- 7) Looks for a Short between electrode and nozzle,(looks for current flow) **Error 21 is invoked if there is no current flow.**

3.3 Power Up Sequence

When the operator closes the torch switch the following occurs:

The Torch Trigger circuit is engaged

Power Board relay RL3, the Mains Contactor Relay, closes.

The Mains Contactor Closes

Power board Relay RL1, the gas solenoid relay, closes.

The gas valve opens

Full buss voltage is available

2 seconds of preflow

The piston in the torch cycles

The Control Board PCB-1 turns on the gating pulses

OCV is available

Control board PCB-1 enables the PA relay signal

The Pilot Arc IGBT passes the Pilot Arc current

Pilot Arc fires

Main Arc is established

Pilot Arc is disabled ***

3.4 Machine Operation Flowchart

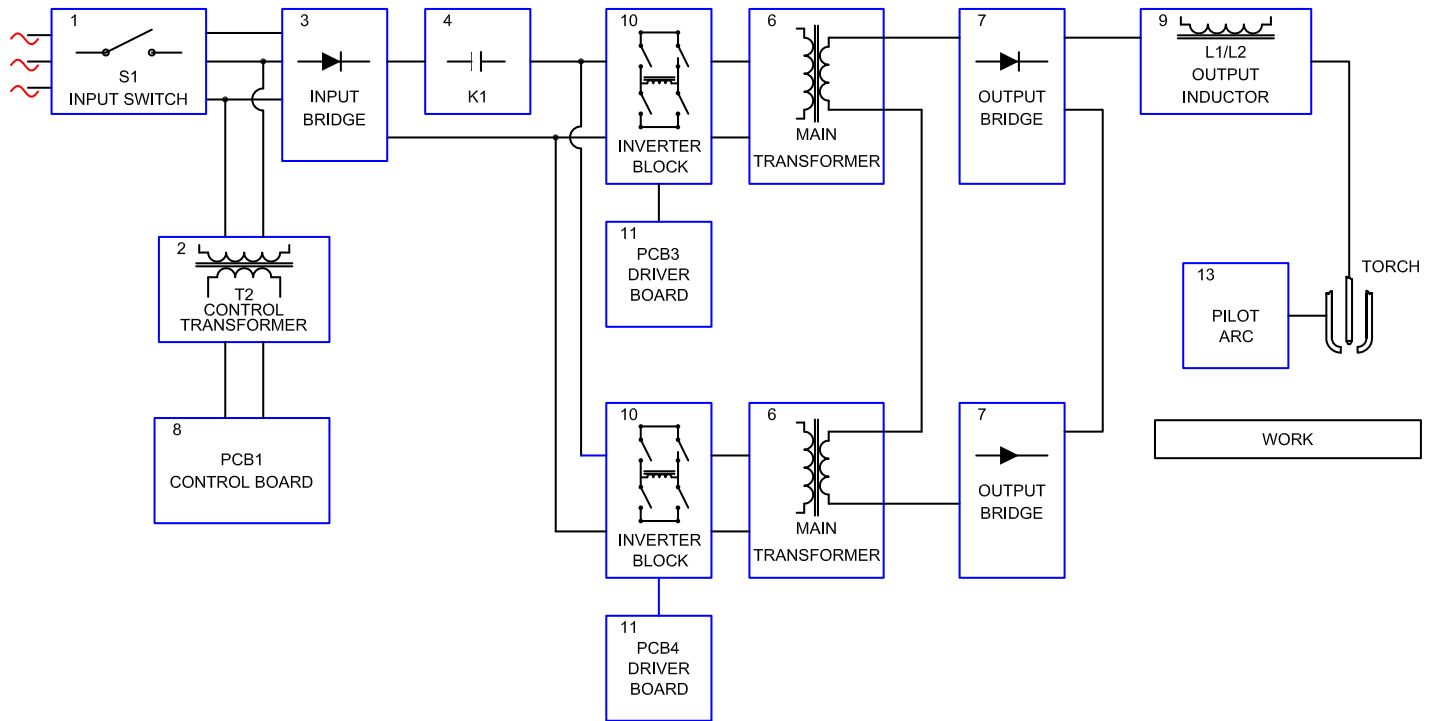

3.5 Component Locator

PC1600 Components		
Symbol	Description	Section # 4.
L1	INDUCTOR INPUT	9
	REACTOR LINE 3 PHASE	
L2	INDUCTOR OUTPUT	
T1	TRANSFORMER MAIN	6
T2	TRANSFORMER CONTROL	2
BR1	BRIDGE RECTIFIER 110A 1600V	3
Q101,102	IGBT DUAL 150A 600V	5
Q103	IGBT 50A 1200V	
D101,102	DIODE MODULE 100A 600V	7
PCB1	PC BOARD - CONTROL / DISPLAY	8
PCB2	PC BOARD - POWER	10
PCB3,4	PC BOARD - DRIVER BOARD	11
PCB5	PC BOARD - PILOT ARC DRIVER BOARD	13
PCB6	PC BOARD - REMOTE	18
PCB7	PC BOARD - EMC FILTER 50A	16
K1	RELAY SPST 24VAC 20A(110VDC) w/ MAG BLOWOUT	4
	CONTACTOR 3P 40A 24VAC	
M1	FAN 6" 230CFM 230V	2
SW1	SWITCH POWER 3P 60A 600V	1
SW2	SWITCH VOLTAGE SELECTOR	5
TS1	SWITCH THERMAL N/C 176°F	12
TS2	SWITCH THERMAL N/C 176°F - Solder	
SOL1	SOLENOID	17
C37, C40, C44,C47,	BUSS CAPACITORS	10.16
C101, C102, C103, C104	BUSS CAPACITORS	10.16

SECTION 4

DESCRIPTION OF OPERATION

4.0 Schematic Section Map 230/460V- 0558007542

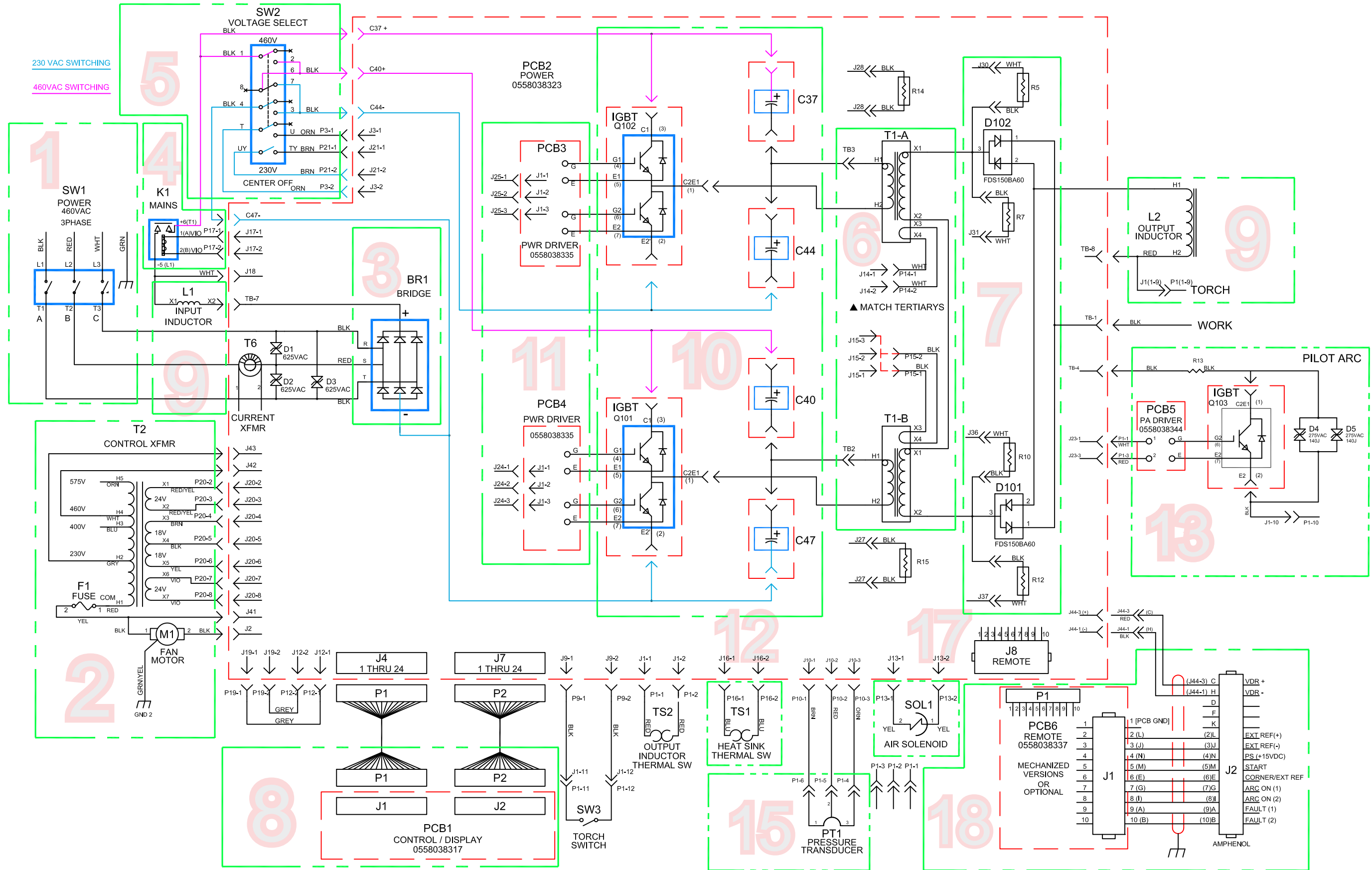

SECTION 4 DESCRIPTION OF OPERATION

4.0 Schematic Section Map 400V/400V CE- 0558007546

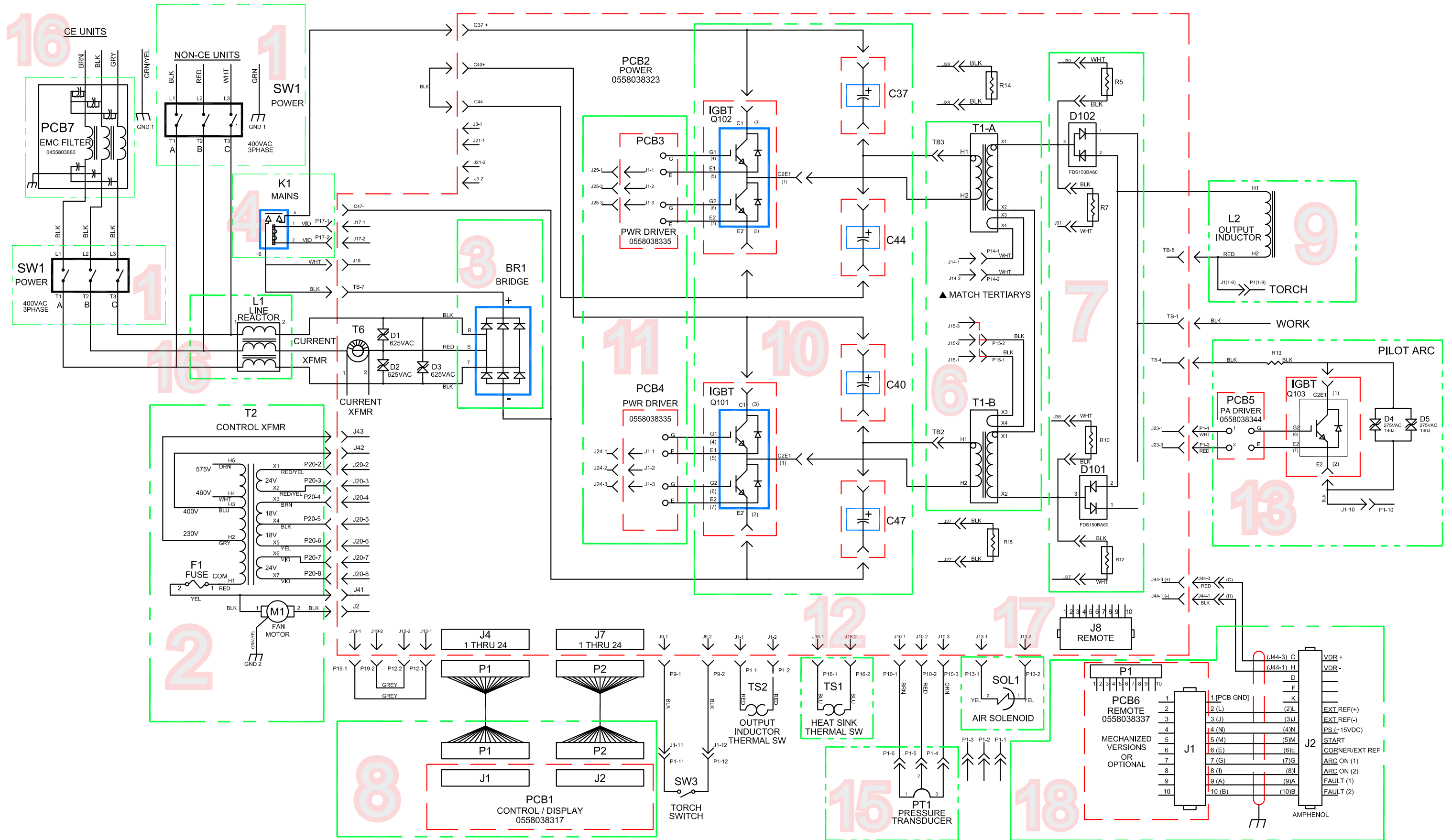

SECTION 4

DESCRIPTION OF OPERATION

4.0 Schematic Section Map 575V- 0558007544

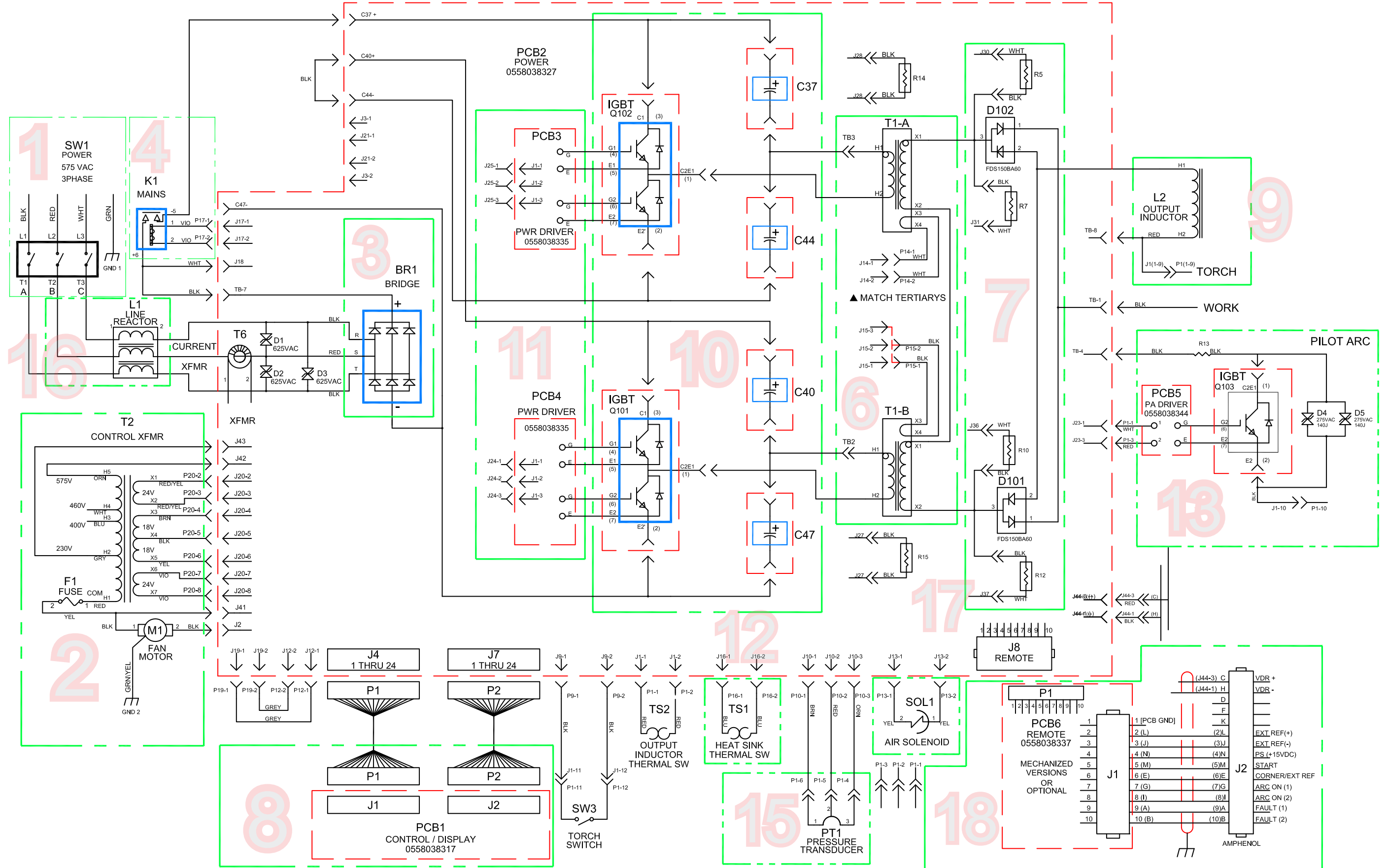

4.1 Main Power Switch S1 (36107)

The main Power Switch is located on the front panel of the unit and passes main input power to the unit. The switch is a triple pole, single throw, rotary type switch, rated for 63 amps of input current at 690 VAC. T6 current transformer, located on the B leg of the S1 output is used to monitor for a single phasing condition. See section 4.10.6 for more information.

Switch testing:

With power disconnected from the unit:

Switch open:

- From pole L1 of the switch to T1 of the switch - open Or High resistance
- From pole L2 of the switch to T2 of the switch - open Or High resistance
- From pole L3 of the switch to T3 of the switch - open Or High resistance

Switch Closed:

- From pole L1 of the switch to T1 of the switch low resistance or shorted
- From pole L2 of the switch to T2 of the switch low resistance or shorted
- From pole L3 of the switch to T3 of the switch low resistance or shorted

DESCRIPTION: PN: 36107 (400/460V UNIT)
 CIRCUIT INTERRUPTER SWITCH 600V 3 PH 3 POLE
 PANEL MOUNTING: FOUR HOLE
 DEGREE OF PROTECTION: FRONT IP55
 UL/CSA & IEC APPROVED
 OPERATIONAL VOLTAGE U_e 690V AC
 OPERATIONAL CURRENT I_e 63A
 AC-21A

UL/CSA
 GENERAL USE 600V AC
 AT 50-60 HZ, 3 PHASE

AC-23A 220-240V 15KW
 380-440V 22KW
 500V 22KW
 660-690V 22KW

UL/CSA 220-240V AC 15HP
 440-480V AC 30HP
 550-660V AC 40HP

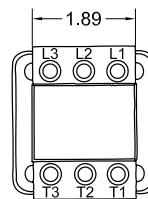
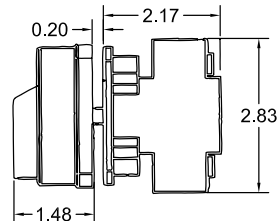
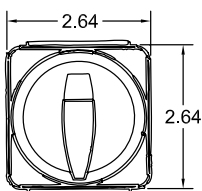
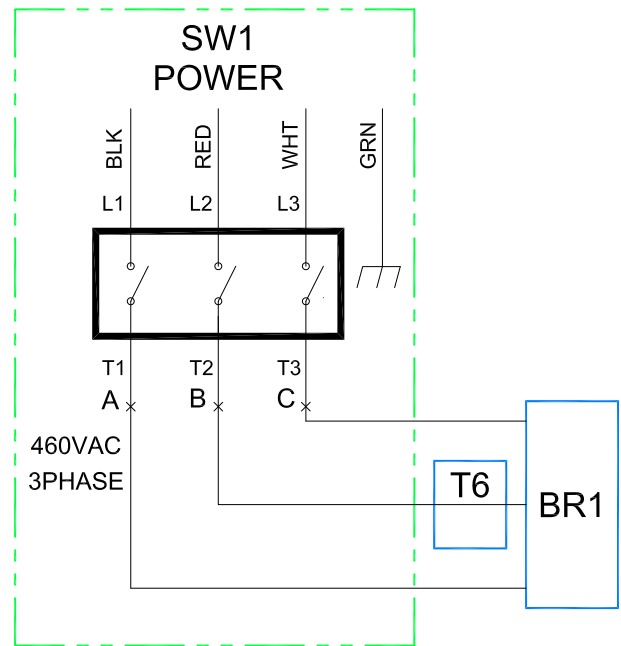
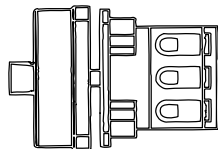
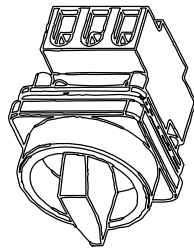

4.2 Control Transformer T2 (0558007188/0558008546)

The auxiliary control transformer is used to step-down the input voltage to levels that can be used as supply voltages for the logic circuits in the PC1600. Since the PowerCut 1600 is available in with different input voltage configurations, the control transformer has a multiple tap primary to allow it to be used in all versions. T2 supplies the following AC voltages to the bias supply circuits on the Power Board PCB3:

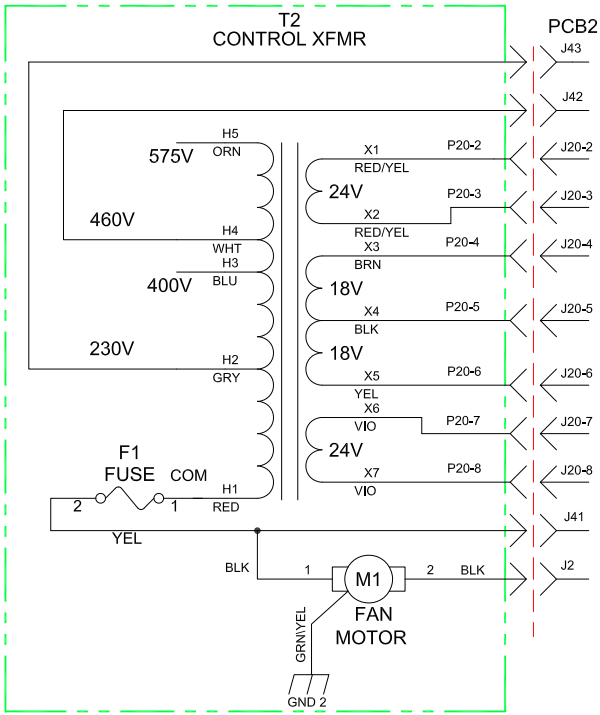

230 V / 460 V Configuration

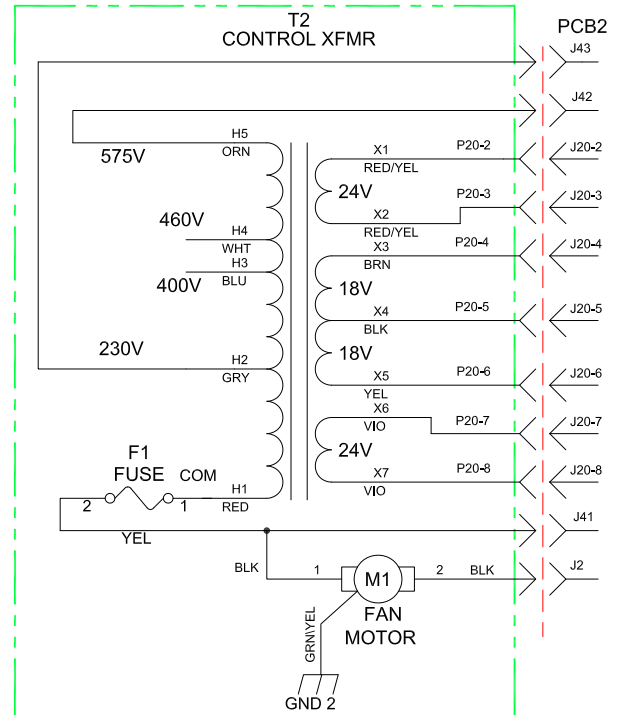

575 V Configuration

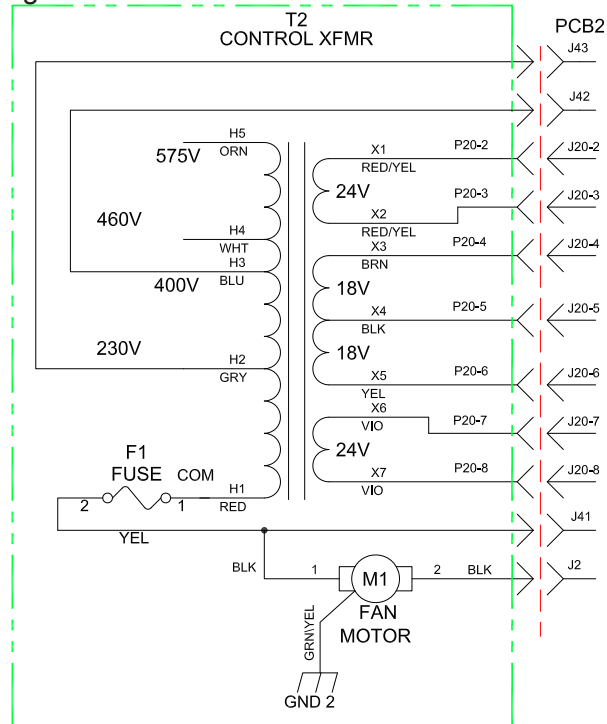

400 V / 400 V CE Configuration

4.2 Control Transformer T2 (0558007188/0558008546)

Control Transformer T2 Schematic(0558007188)

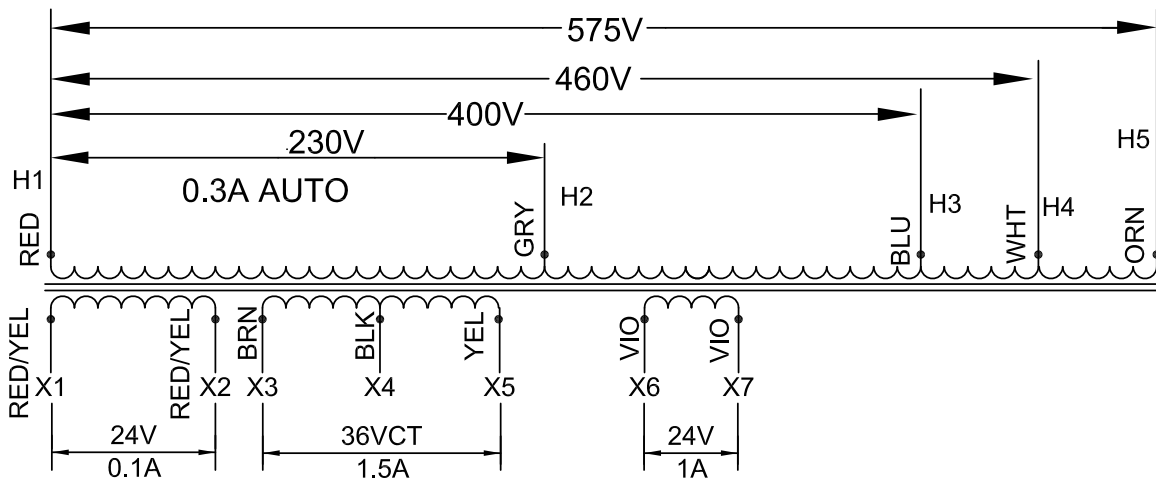

SCHEMATIC DIAGRAM

Transformer T2 (0558007188)				
Lead	Color	Input Voltage	Resistance	
			Leads	Ohms
H1	RED	Common		
H2	GREY	230	H1 - H2	< 1 ohm
H3	BLUE	400	H1 - H3	< 1 ohm
H4	WHITE	460	H1 - H4	< 1 ohm
H5	ORANGE	575	H1 - H5	< 1 ohm
Output Voltage				
X1/X2	RED/YELLOW	24 VAC	X1 - X2	< 1 ohm
X3	BROWN	18 VAC	X3 - X4	< 1 ohm
X4	BLACK	CT 0 V		
X5	YELLOW	18VAC	X4 - X5	< 1 ohm
X6/X7	VIOLET	24 VAC	X6 - X7	< 1 ohm

H1-H2 is excitation voltage

Ohms test Primary to Secondary. Any H connection to any X must read "OPEN"

4.2 Control Transformer T2 (0558007188/0558008546)

Control Transformer T2 Layout (0558007188)

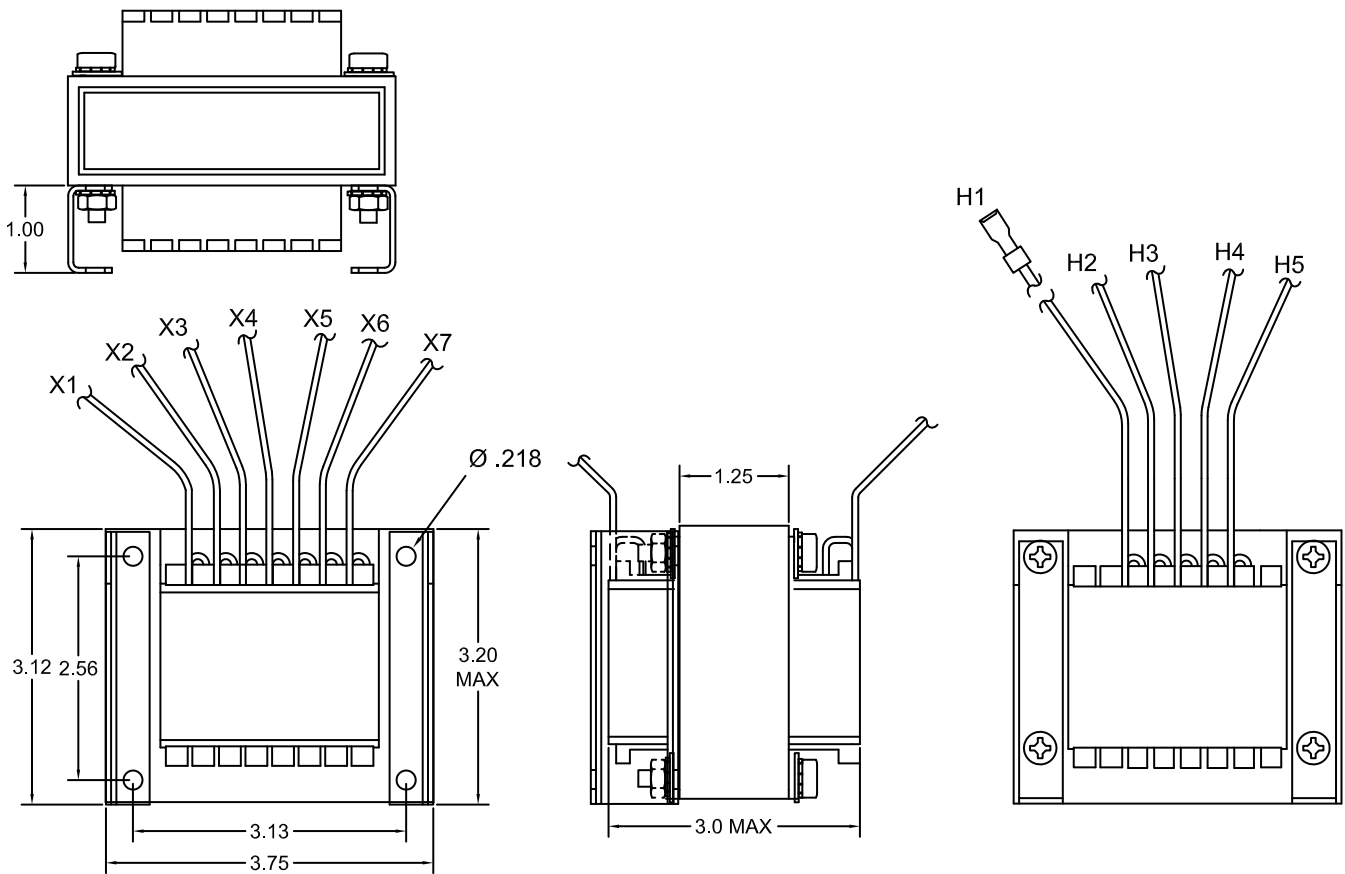

Control Transformer T2 Schematic (0558008546)

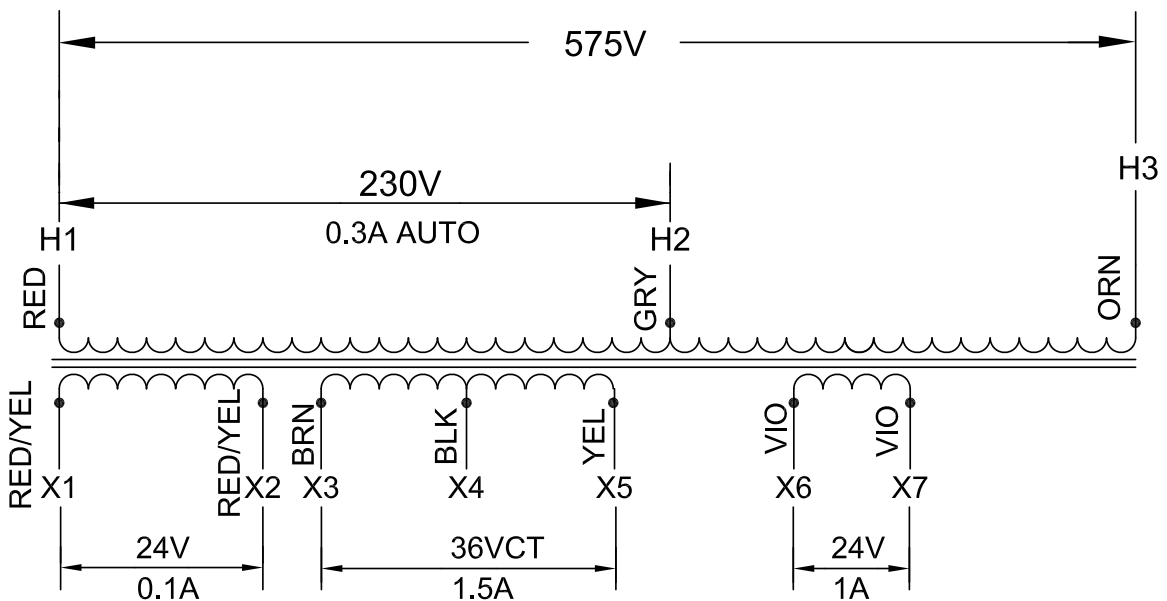

SCHEMATIC DIAGRAM

SECTION 4

DESCRIPTION OF OPERATION

4.2 Control Transformer T2 (0558007188/0558008546)

Control Transformer T2 Layout (0558008546)

TERMINAL	VOLTAGE
H1 - H2*	230
H1 - H3	575.0 ± 1.0%
X1 - X2	25.5V ± 1.0%
X3 - X4	20.5V ± 1.0%
X3 - X5	41.0V ± 1.0%
X6 - X7	26.8V ± 1.0%

*H1-H2 COIL IS EXCITATION WINDING

LEAD LIST			
POINT	COLOR	LENGTH	TERMINATION
H1	RED	12	AMP 2-520183-2
H2	GRAY	13	STRIP .38
H3	ORANGE	11	STRIP .38
X1	RED/YELLOW	12	STRIP .25
X2	RED/YELLOW	12	STRIP .25
X3	BROWN	12	STRIP .25
X4	BLACK	12	STRIP .25
X5	YELLOW	12	STRIP .25
X6	VIOLET	12	STRIP .25
X7	VIOLET	12	STRIP .25

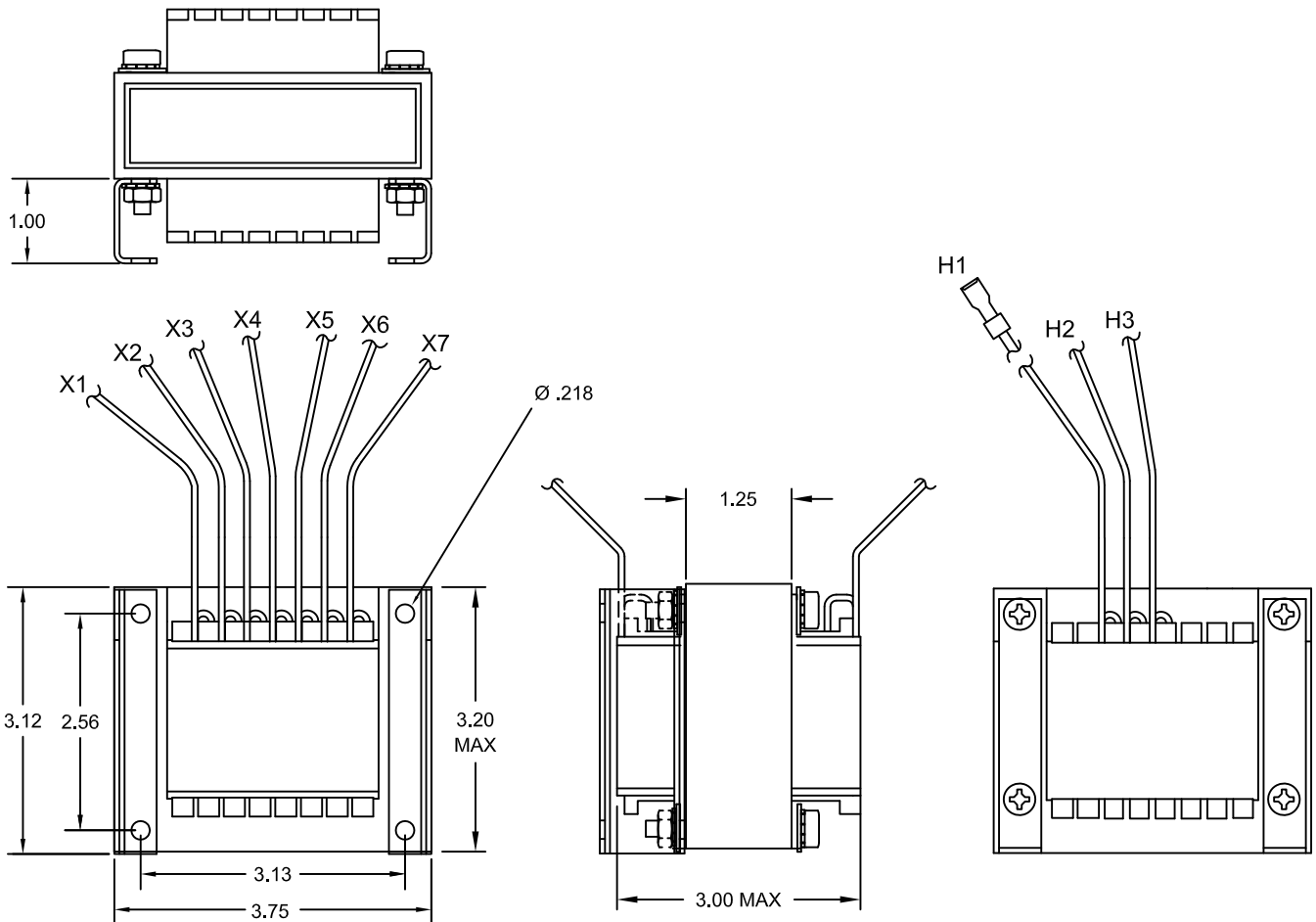

SECTION 4

DESCRIPTION OF OPERATION

4.2.1 Axial Fan (951182)

The side mounted fan M1 is used to circulate cooling air across the active devices, (the IGBTs, IBR and D101 and D102) inside the cabinet. The fan starts when the torch trigger is depressed and will continue to run for up to seven minutes after the cut has ceased. There is a variable timing circuit at work here. The timing circuit will keep the fan running for the same amount of time the torch was cutting. In other words, if the torch was turned on for two minutes, the fan will continue to run for two minutes after the torch was turned off. This 1:1 ratio will work up to a maximum of seven minutes. The maximum fan on time is seven minutes after the torch is turned off.

The fan input power wire is connected on one side to the 230-volt primary at the T2 transformer, and the other wire is connected to the power board PCB2 at J2. The J2 connection is routed to the Fan relay, RL2, for activation from the main control board PCB1. The 230 volt AC power connection is completed through the contacts of RL2, to J42

Testing:
Open circuit resistance is 150 Ohms.

Specifications:
5.9 DIA. x 2.16 In., 247.2 CFM
230V 60Hz/ 55dB(A)/ -40 ~ +55°C
Metal housing and impeller
Shaded pole motor, air output over struts
Elec. connection via 2 leads AWG 18, 14 in. (365 mm) from outer edge of housing.
Mass = 38.8 oz (1100g)

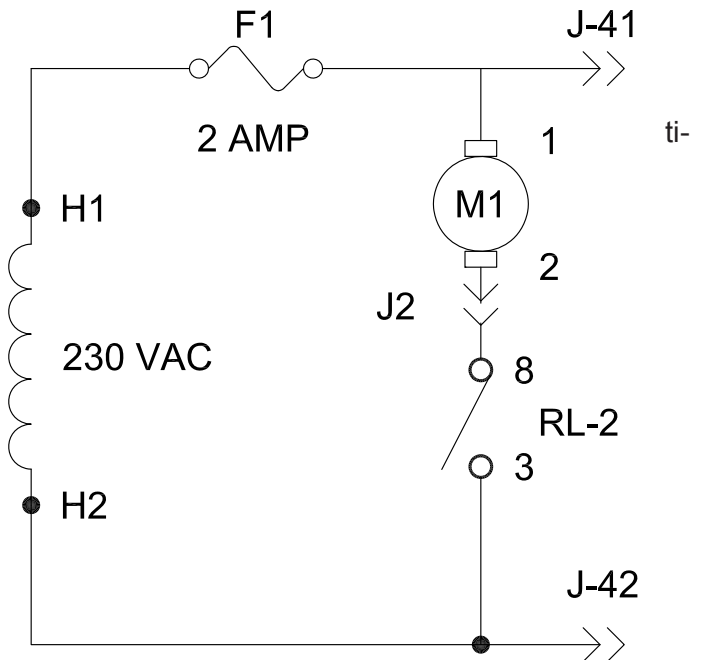

AC AXIAL FAN
5.9 DIA. x 2.16 In., 247.2 CFM
230V 60Hz/ 55dB(A)/ -40 ~ +55°C
Metal housing and impeller. Shaded pole motor, air output over struts.
Elec. connection via 2 leads AWG 18, 14 in. (365 mm) from outer edge of housing.
Mass = 38.8 oz (1100 g).

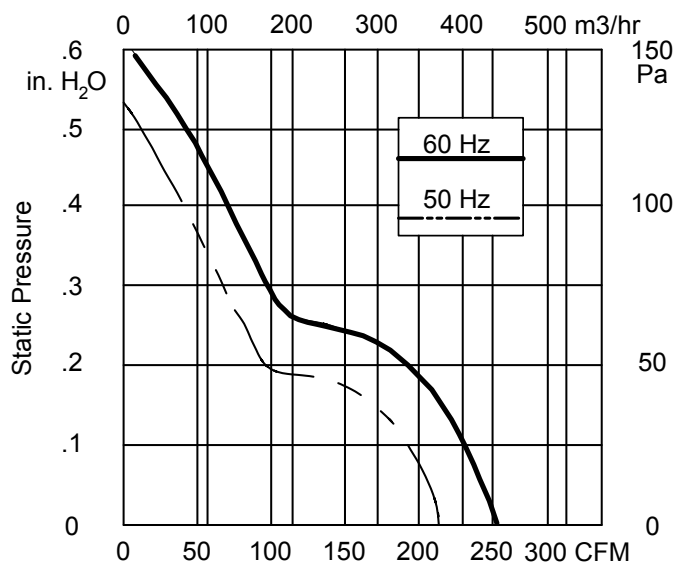
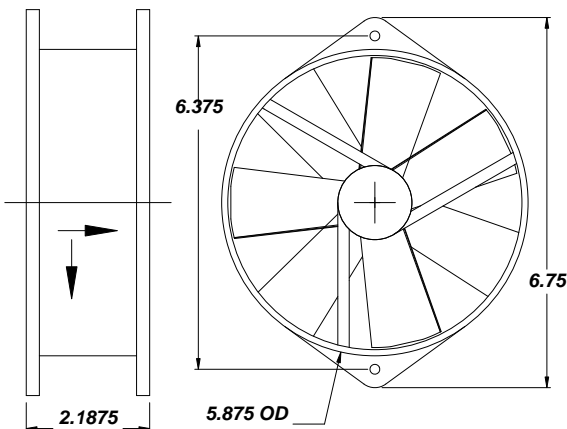

4.3 Input Bridge (0558007068 / 0558007077)

The input bridge is a 3 phase, full wave rectifier, which converts the AC input voltage to DC. The device is designed to deliver a maximum current of 160 Amps of forward current. Primary AC power enters the rectifier where it is rectified by the six diodes inside BR1. The rectified output is coupled to the buss supply capacitors and the L1 input inductor.

A “precharge” Inrush circuit is mounted to the output of L1 and is in parallel with the Main Contactor. This circuit allows the Buss supply to charge gradually during initial power up. When the operator closes the torch trigger, the Main Contactor is used to supply full current output to the buss supply.

Testing: 760K Ohm forward resistance, reverse resistance - high resistance (1.5 Meg-Ohm or greater) out of circuit. In circuit resistance is 99 K Ohm.

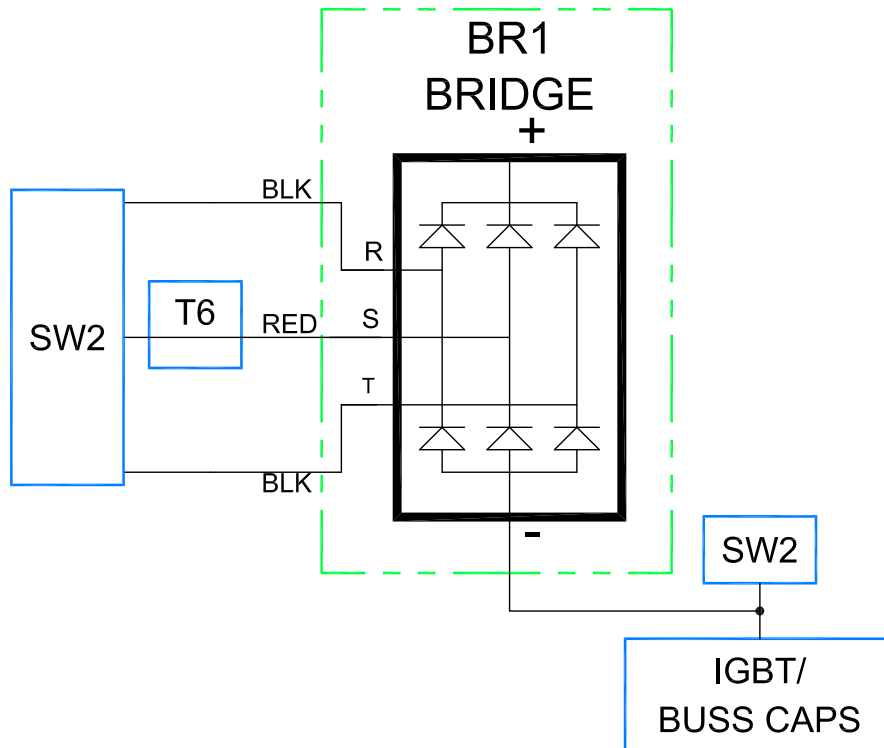

4.3 Input Bridge (0558007068 / 0558007077)

0558007068

V_{RSM}	V_{RRM}	V_{DRM}	$I_D = 110A$ (FULL CONDUCTION)
V	V		($T_C = 100^\circ C$)
1600	1600		SKD 110/16

0558007077

V_{RSM}	V_{RRM}	V_{DRM}	$I_D = 160A$ (FULL CONDUCTION)
V	V		($T_C = 100^\circ C$)
1600	1600		SKD 160/16

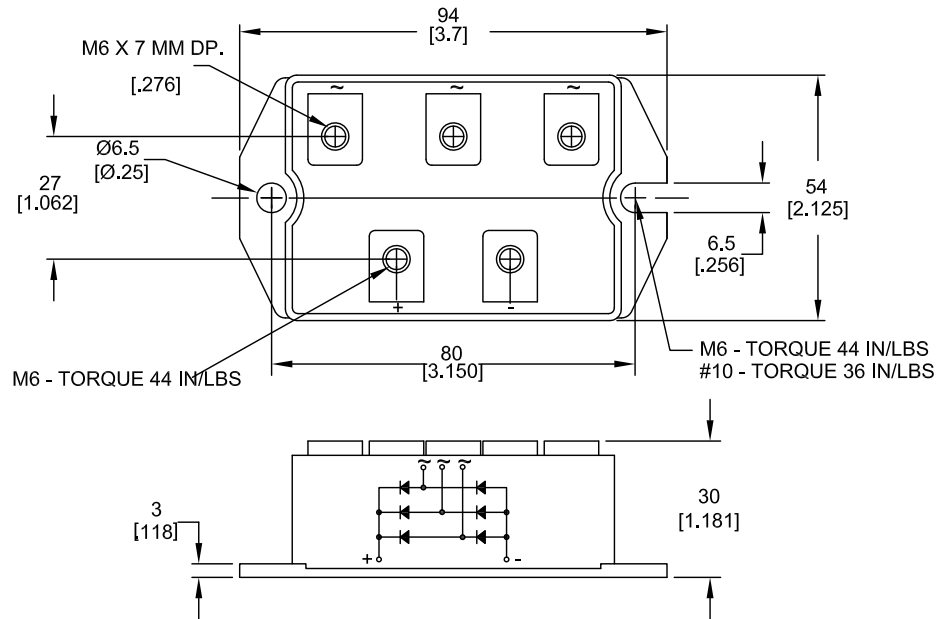
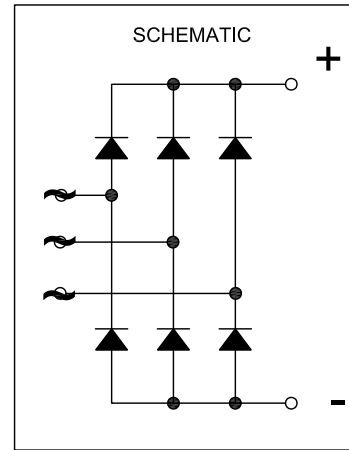

SECTION 4

DESCRIPTION OF OPERATION

4.4 Contactor K1 (950247 / 0558002576)

The Main Contactor Relay K1 is the main power relay on this unit. When the torch switch is closed, the control board PCB1 supplies 24VAC to the coil of the relay. This allows the relay to energize which allows full power to be applied to the filter buss.

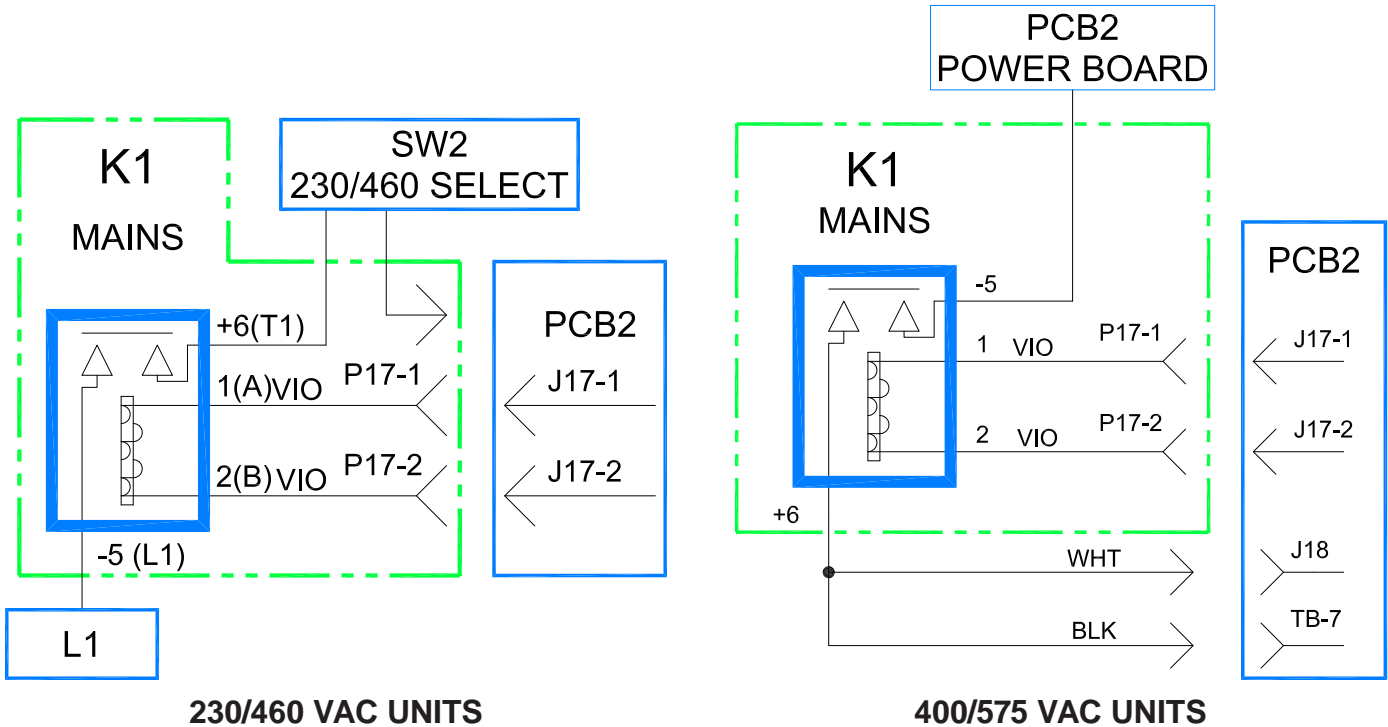

DESCRIPTION

RELAY (1 FORM C) SPST-NO-DM W/MAG. BLOWOUT
 COIL RATING: 24VAC 50/60 Hz
 CONTACT MAT'L: SILVER CAD OXIDE W/PERMANENT MAG BLOWOUT
 CONTACT RATING: 20A @ 110 VDC, NON CONDUCTIVE
 TERMINATION: COIL- FAST-ON 1/4
 CONTACT- 8-32 SCREWS

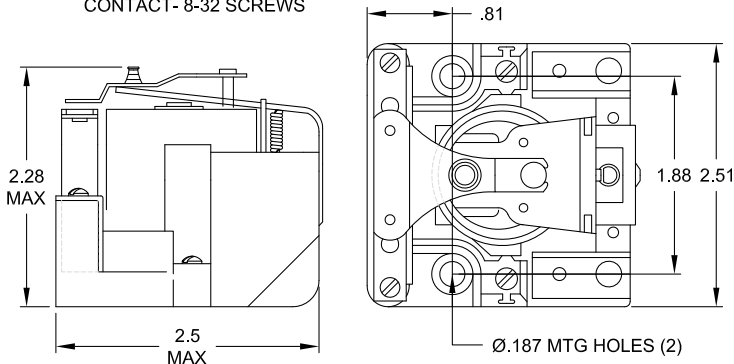

DESCRIPTION:

AMPS: 40 INDUCTIVE
 NO. OF POLES: 3
 COIL VOLTAGE: 24
 MAIN TERMINAL: BOX LUGS ON BOTH SIDE & DOUBLE QUICK CONNECT ON LINE & LOAD
 AUX. PWR. & COIL TERMINALS: .250 QUICK CONNECT
 WIRE RANGE : 14-6 AWG
 UL RECOGNIZED
 CONTACTOR TO BE SUPPLIED WITH COVER OVER CONTACTS
 MTG SCREW = #10
 NOTE: GRAPHIC FOR REFERENCE ONLY

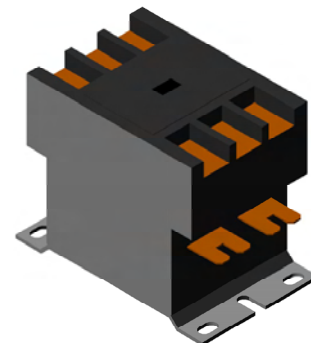

4.5 Voltage Selector Switch SW2 (0558007183)

The Voltage Selector Switch is a three position switch designed to alter the configuration of the filter bus to accommodate 230 VAC or 460 VAC input voltages. This switch is only in the 230/460 VAC selectable models.

The filter caps are configured in two different ways in the PC1600 230/460 model, dependant upon the input voltage. The power selector switch SW2 will place the four filter capacitors in either a series configuration or in a parallel pair configuration.

The Voltage Selector switch is a three position switch with a center “Off” position. If this switch is changed during normal operation, the system will shut down to prevent damage to the unit. The unit will remain inoperable until it is shut off and powered back up. If the voltage input is incorrect, the machine will give you a voltage fault.

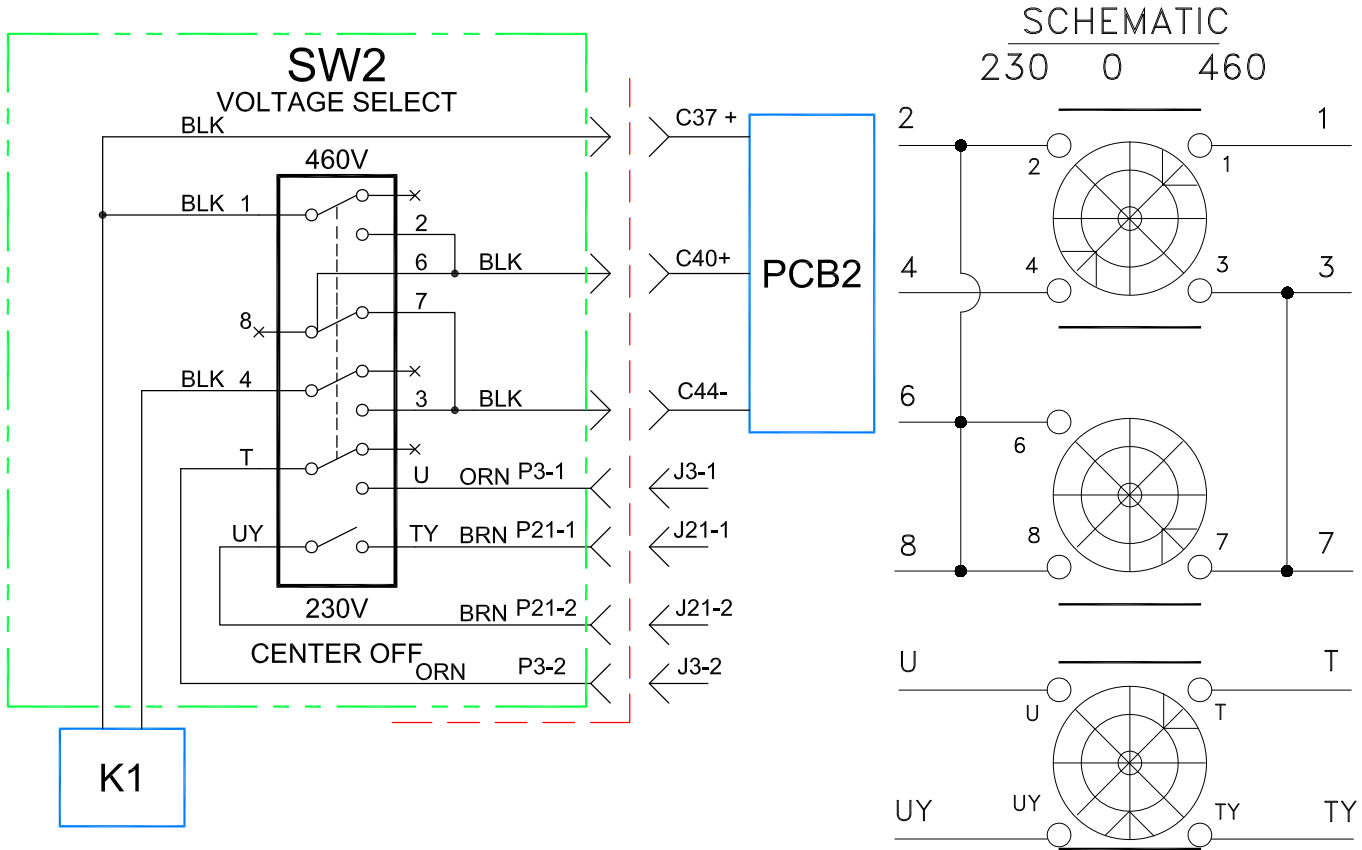

4.6 Main Transformer T1 (0558007189 / 0558007190 / 0558007191)

The Main Transformer T1 accepts the 18.5 KHz AC power from the IGBTs and steps the voltage down before sending it to the output diodes where it is rectified to DC before being sent out to the torch.

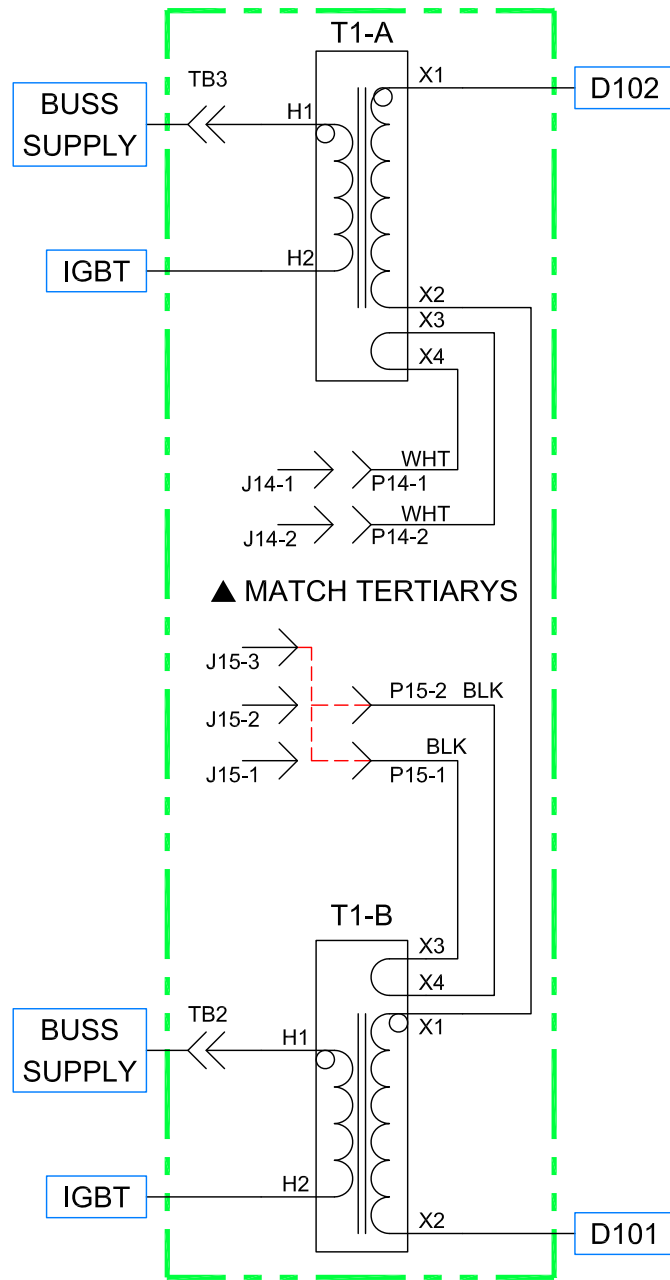

4.6 Main Transformer T1

4.6 Main Transformer T1 (0558007189 / 0558007190 / 0558007191)

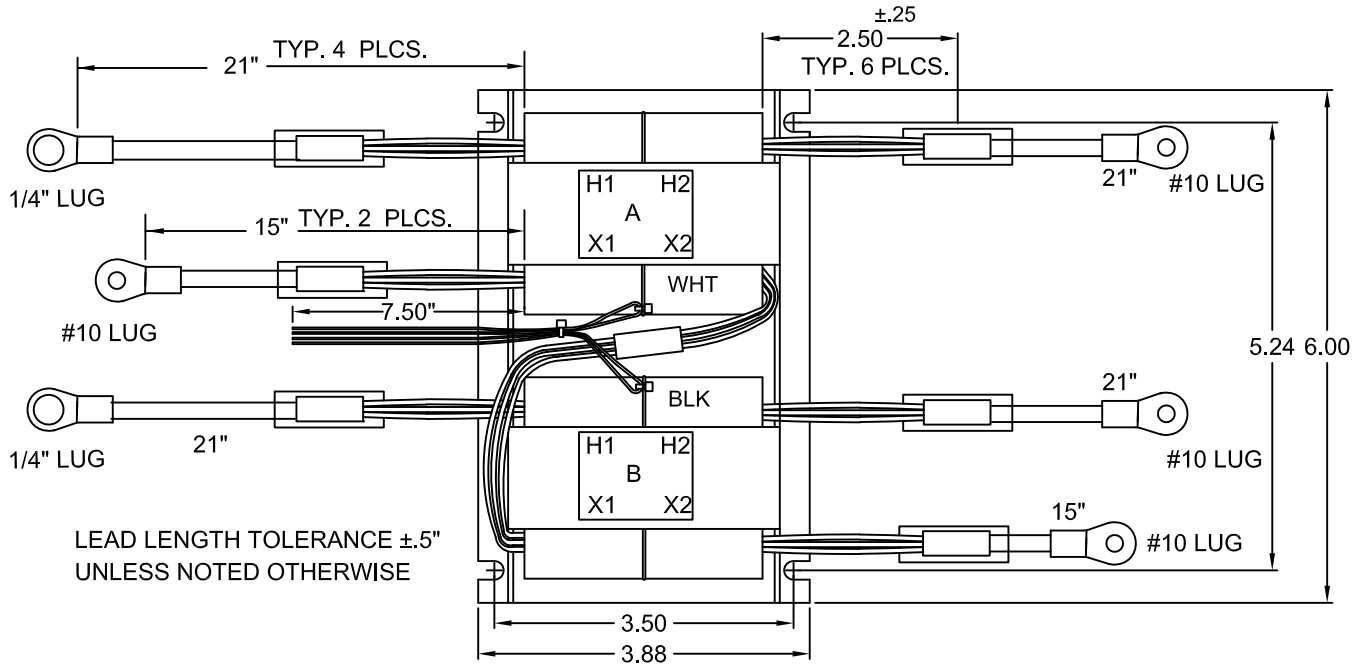

4.7 Output Diodes D101, D102 – (951185)

The two output diode modules consist of two diodes in each module connected to make a full wave bridge. These modules are each rated at 100 Amps of forward current at 600 VDC.

D101- D102 DIODE			
RED LEAD	BLACK LEAD	RESISTANCE (OHMS)	
+	-	OUT OF CIRCUIT	IN CIRCUIT
1	2	OPEN	20K
1	3	3.8K	14K
2	3	7.8K	4.8K
2	1	3.8K	900 ohms
3	1	OPEN	900 ohms
3	2	OPEN	12.2K

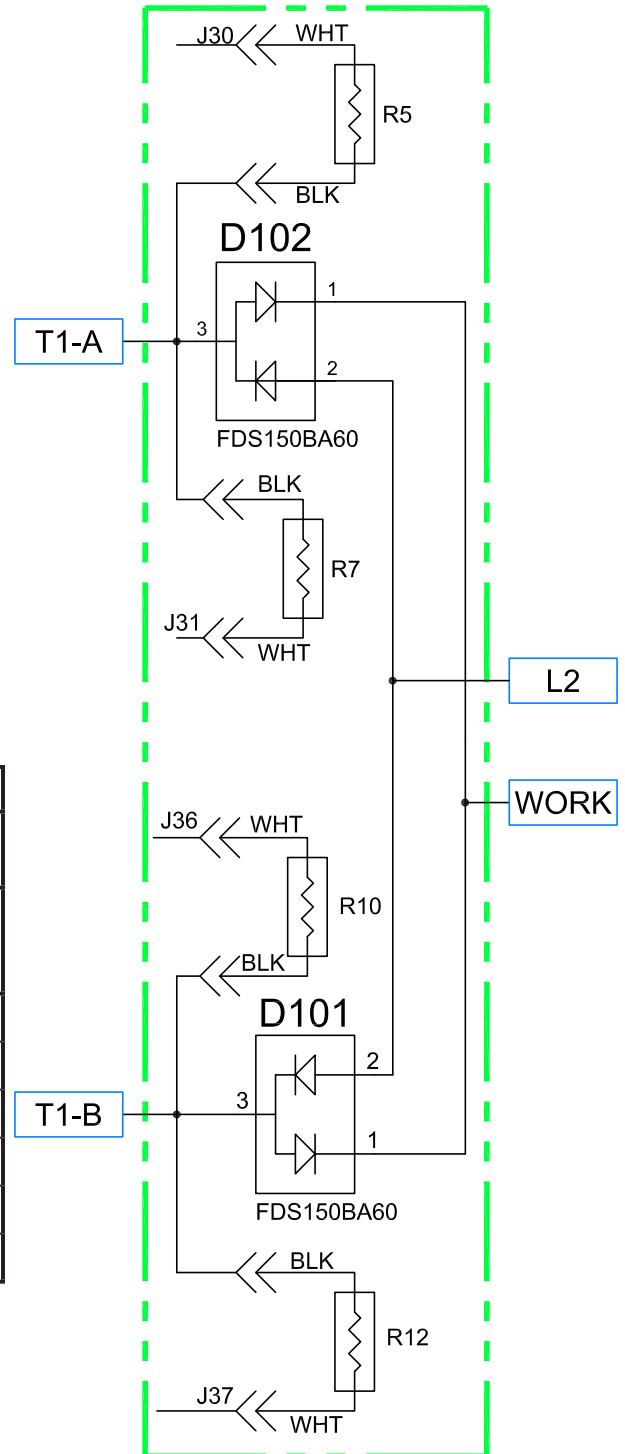

4.8 PCB1 Control/Display Board (0558038317)

Description:

The main control board is responsible for most of the control functions of the PC1600. This board controls the Pulse Width Modulator, CNC interface, power up sequence, gas pressure control, error signals and the display. The board receives its' power from the power board bias supplies to operate and also creates a 5VDC bias supply on board.

For the purpose of explanation and troubleshooting the board is broken down into sub-circuits. Board level repair is not recommended.

SECTION 4

DESCRIPTION OF OPERATION

4.8 PCB1 Control Board (0558038317)

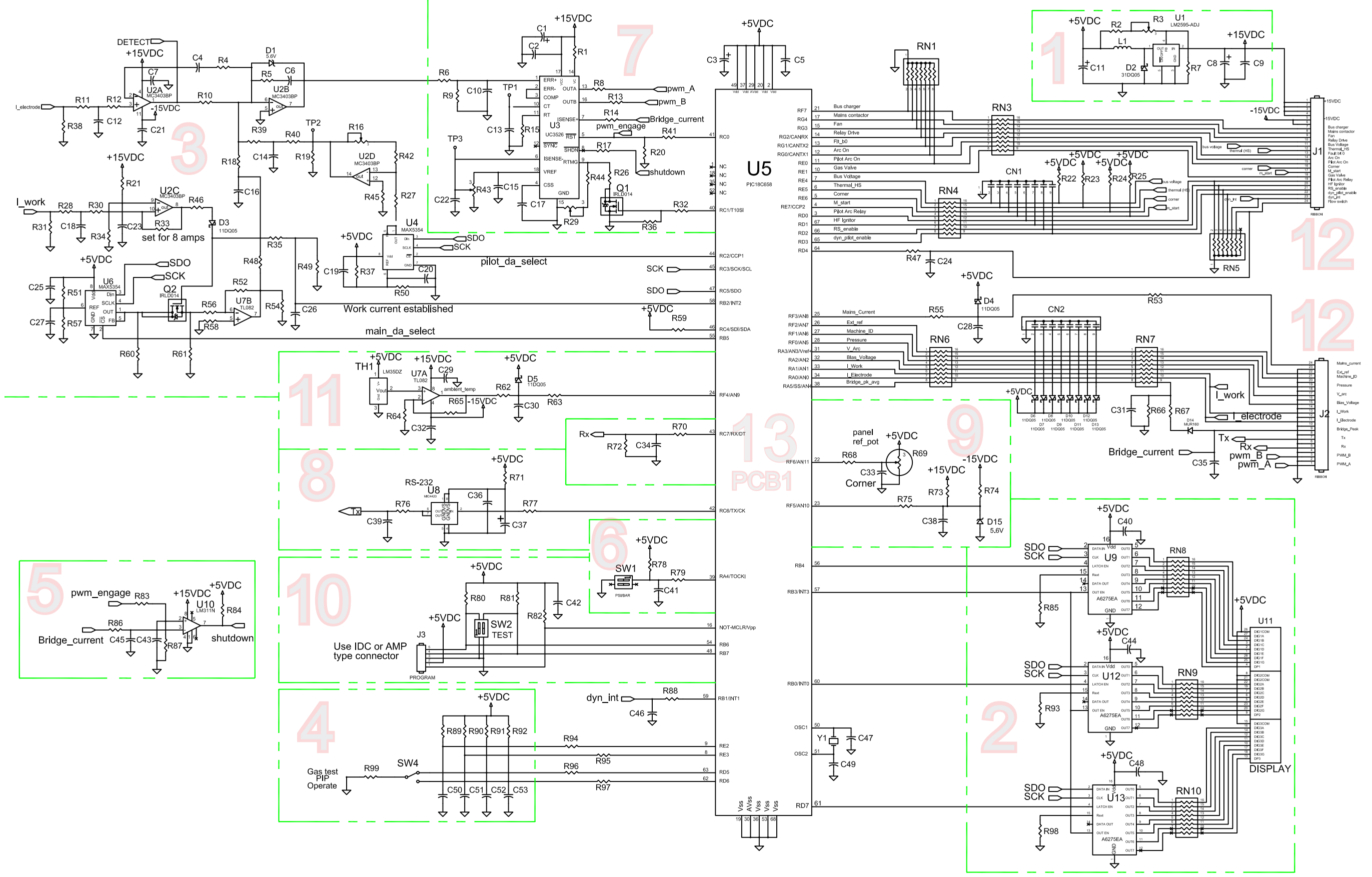

4.8.1 PCB1_Bias Supplies (0558038317)

POWER

The Board receives +15 VDC and -15 VDC from the power board via the ribbon cable at J1. The +15 VDC is connected on J1 pins 1 -4 (to divide the current among the 4 conductors) and passed to the +5VDC supply circuit and also distributed to the different circuits on the board. The negative 15 VDC is brought in on the J1 connection at pins 5 and 6 , and then sent to the board circuits.

+5VDC Supply

The +15 VDC input is branched off to supply U1 which is being used as the regulator for the +5 VDC supply. This voltage is distributed throughout the board and to the current reference pot R69.

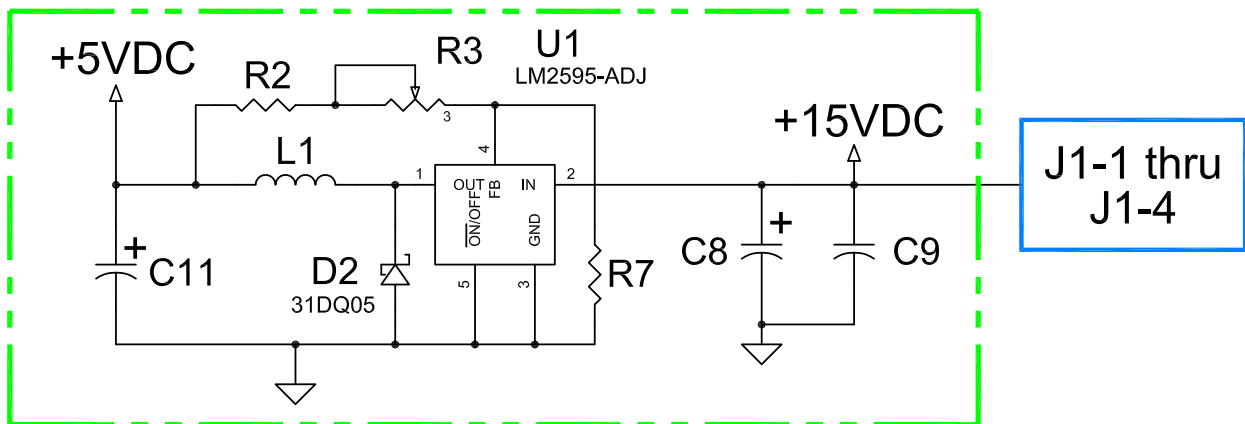

4.8.2 PCB1_Display (0558038317)

The Main control board microcontroller outputs the digital signals to the display driver chips. These chips then drive the displays mounted on the control board.

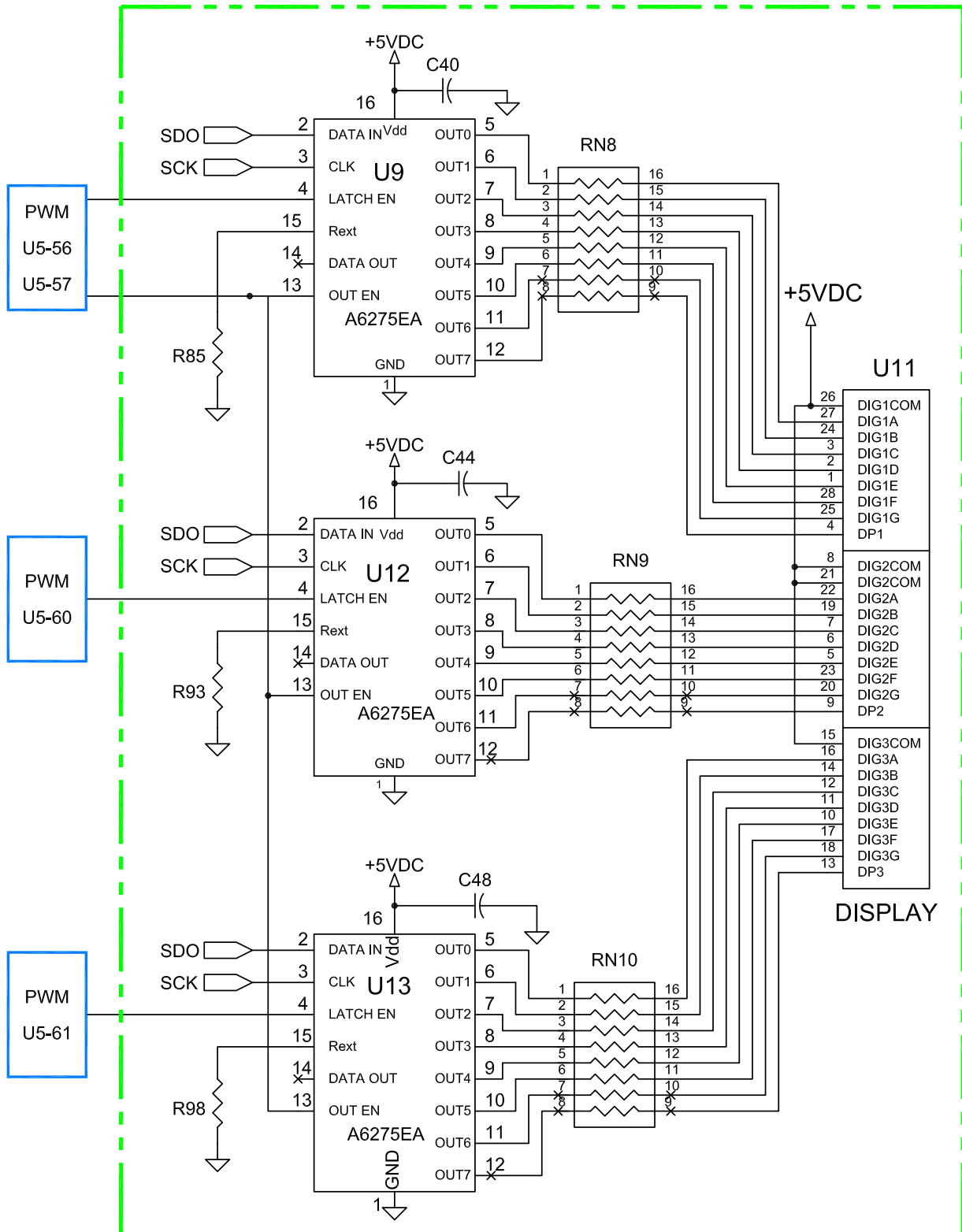

4.8.3 PCB1_Error Amp / Current Reference (0558038317)

The Control board sets the current output level and receives the error signals from the hall sensors mounted on the power board. The control board micro controller receives the current reference input current reference circuit and then outputs that on U5 pin 47 as the SDO signal. This combined with the clock signal SCK on U5 pin 45 set the current reference level on U4 and U6. These reference signals are summed against the signals from the hall sensors to set the current signal.

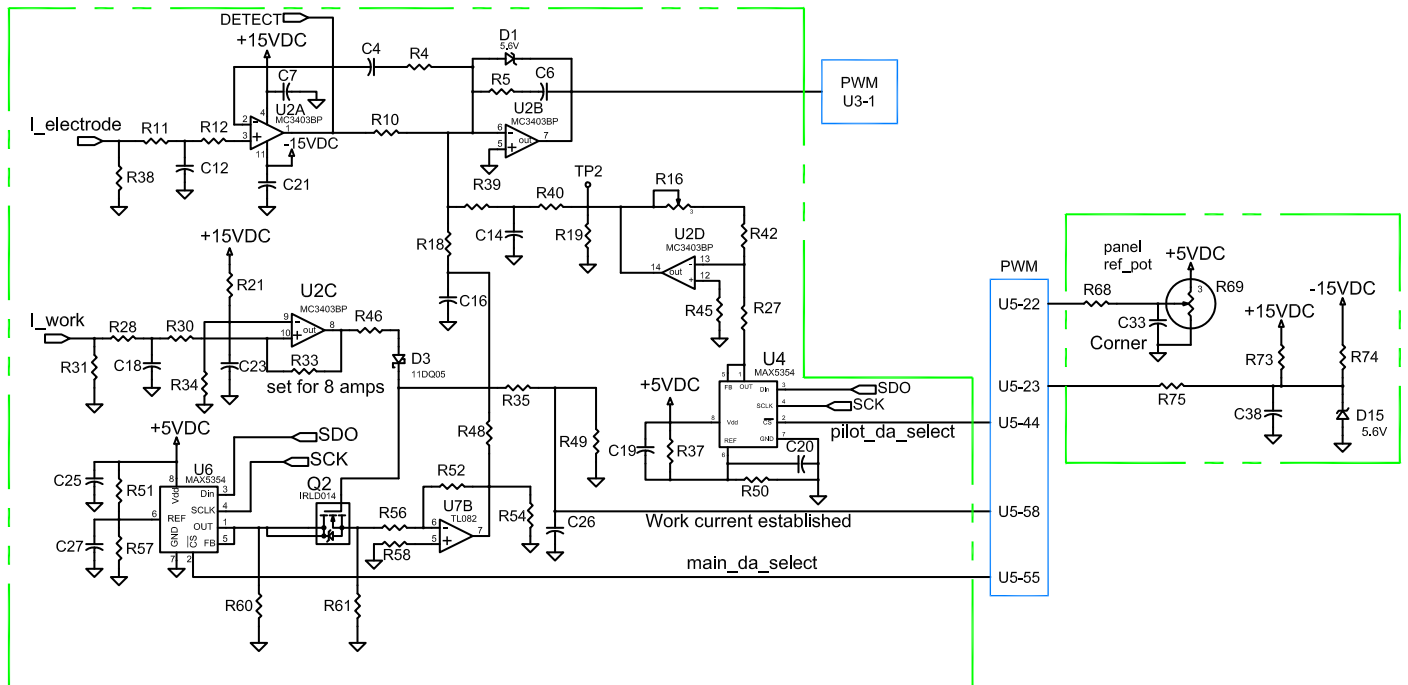

4.8.4 PCB1_Mode Switches (0558038317)

The Mode select switch (SW4) is a three position switch used to determine the mode of machine operation. In the up position the unit is in "Gas Test" mode, allowing air to flow through the torch for setting inlet pressures.

In the center position, Normal Mode, the unit is in "Operate Mode.

In the down position,(Trigger Lock) the torch trigger can be released after an arc is established and the arc will continue until the trigger is activated and released a second time.

SW4 is hard mounted directly to the control board, allowing the toggle to extend through the front panel.

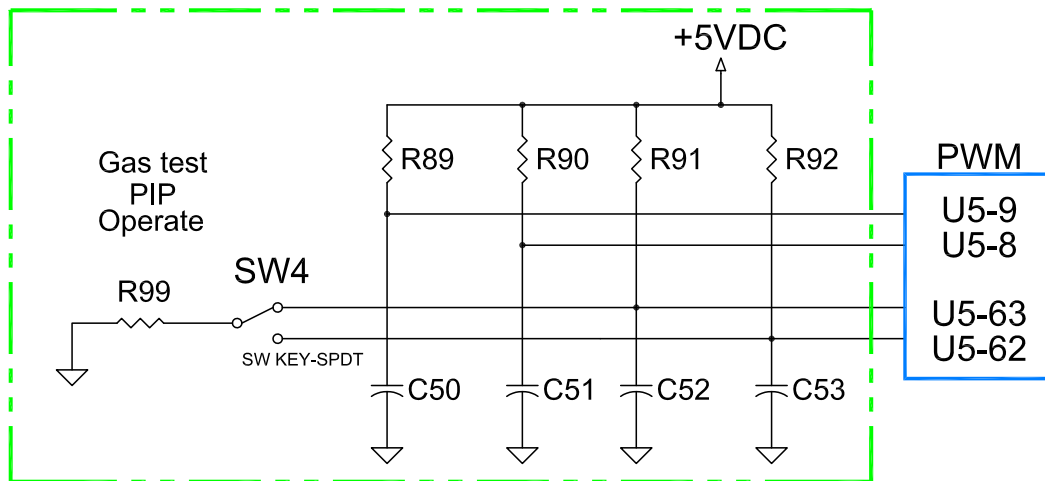
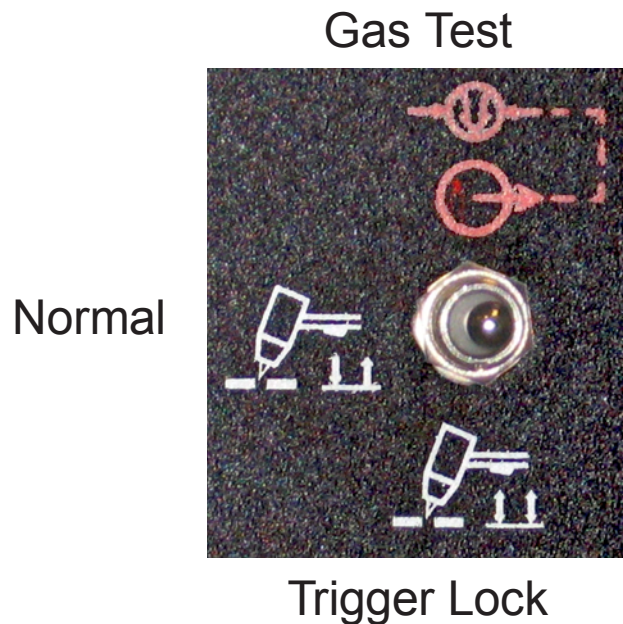

4.8.5 PCB1_Protection Circuit (0558038317)

The Protection Circuit is designed to prevent the PC1600 from producing output current without a trigger signal present. The comparator circuit senses if output current is above zero when the pwm_engage signal is not present. It automatically shuts down the pwm circuit if that condition exists. This a redundant control to ensure that a single circuit failure does not result in a dangerous output condition.

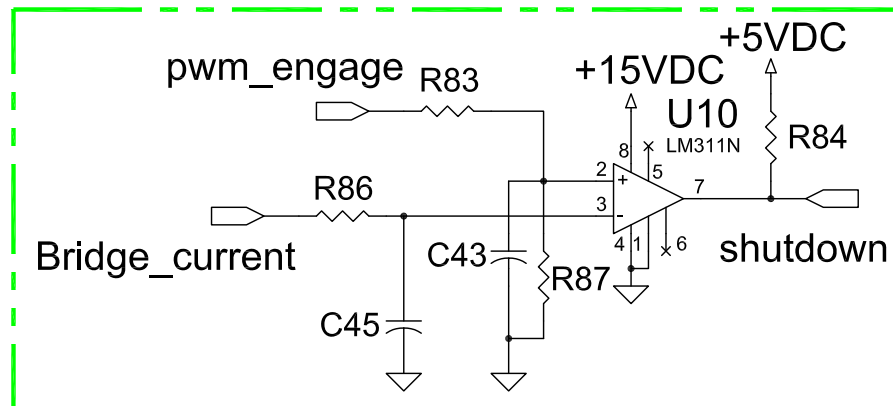

4.8.6 PCB1_Gas Test Operate Switch (0558038317)

The Display switch on the PCB1 control board allows the operator to choose the units of measurement for the Gas, in Pounds per Squire Inch (PSIG) or in (Bars) to be displayed on the front panel LED display. SW1-2 has no function. SW1 is hard mounted to the Main Control board.

With SW1-1 in the **OFF** position the unit will display gas pressure in **PSI** units.
With SW1-1 in the **ON** position the unit will display gas pressure in **BAR** units.

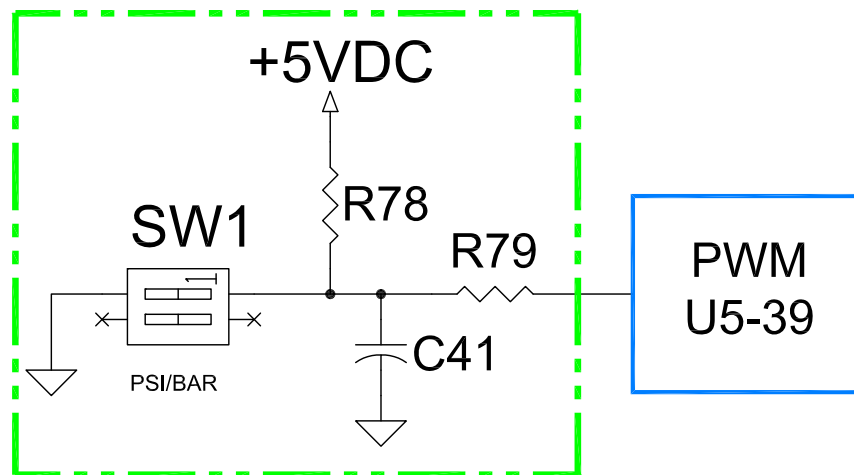

4.8.7 PCB1_PWM Circuit (0558038317)

PWM / IGBT Gating signal

This section controls the frequency and width of the gating signal supplied to the IGBTs.

The circuit receives the current reference signal from the current reference and error amplifier.

This circuit is triggered on from the microcontroller. In the event that there is an over current condition the PWM chip can be shut down from either the microcontroller or from the Protection circuit (see Protection Circuit section XX)

The PWM circuit receives an enable signal from the microcontroller chip to begin the output of pulses that are then sent to the Power Board via the ribbon cable.

The PWM chip receives the current reference signal on pin 1, the ERR pin, which it receives from the error amplifier.

Adjustment

Adjust R29 to read 38 KHz at TP1

Adjust R43 to read 1.45 VDC at TP3

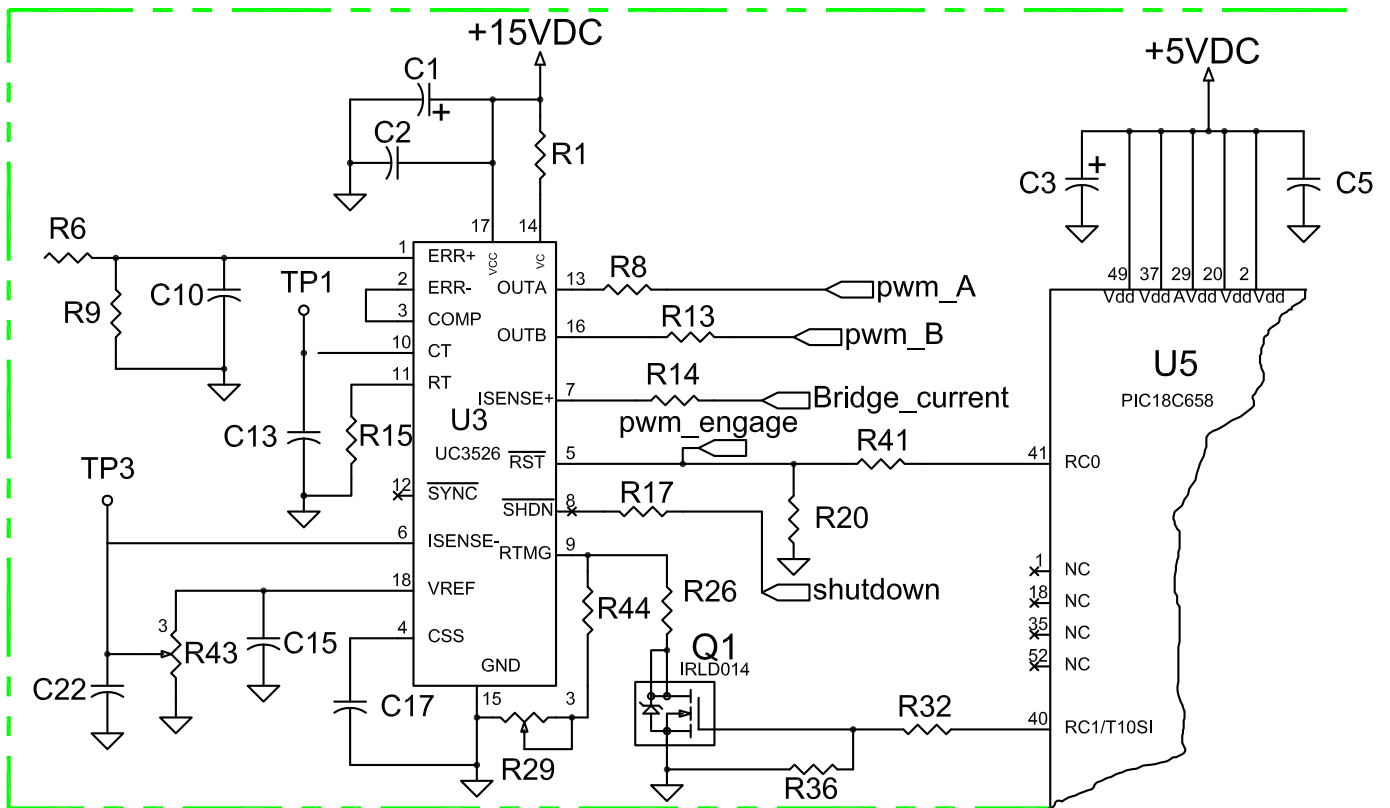

4.8.8 PCB1_RS232 Input (0558038317)

Serial Input Circuit

The Serial Input circuit is used for the Power Board PCB2 to communicate to the Main Control Board. This is an RS232 interface and is used primarily for the Power Board to identify itself to the Main Control board.

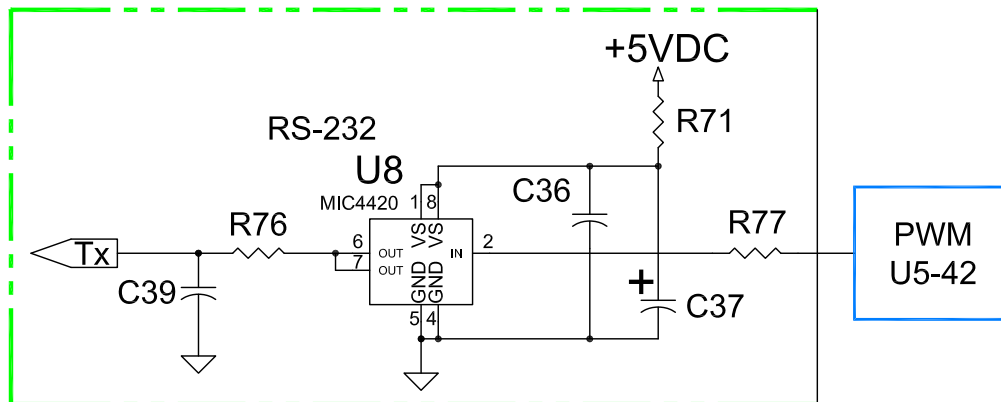

4.8.9 PCB1_Current Reference (0558038317)

The output current level of the PC1600 is set from the board mounted potentiometer (R69) that extends through the front panel of the console.

The wiper of this pot is connected to the microcontroller through resistor R468. The pot is connected across 5 volts and ground. The resulting voltage divider from the wiper varies the voltage sent to the microcontroller. This varies the output of the PWM circuit, and so, varying the current output of the PC1600.

R69 is a 10 K Ohm potentiometer.

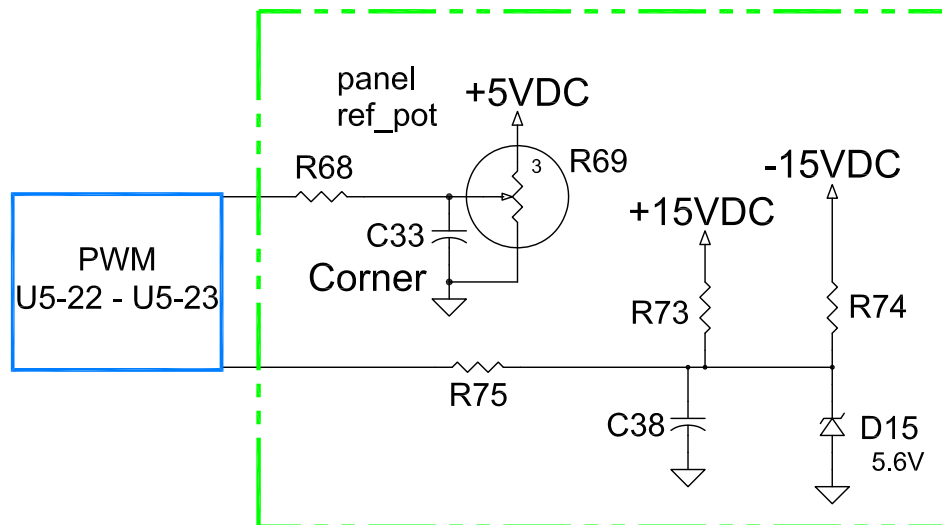

4.8.10 PCB1_Programming Port(0558038317)

The programming port on the board is used to program the main control board microcontroller at the factory. Field programming of the unit is not necessary.

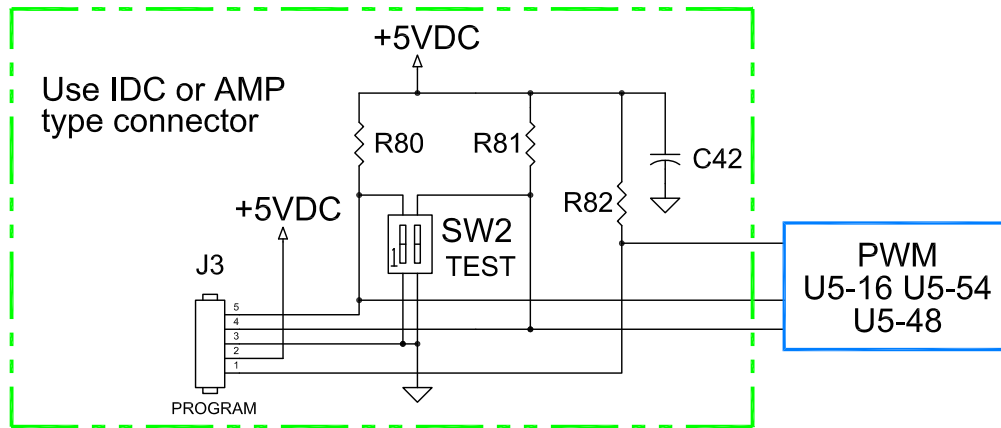

4.8.11 PCB1_Thermal Sensing Circuit (0558038317)

The Main Control Board has a temperature sensing circuit built into it for circuit protection. If the temperature in the case exceeds 40 degrees centigrade(104 deg F), the microcontroller will shut down the unit. The precision temperature sensor TH1 is connected to a comparator, U7A. When the voltage out from TH1 exceeds 400 millivolts the comparator sends out a signal to the microcontroller and the microcontroller shuts the unit down.

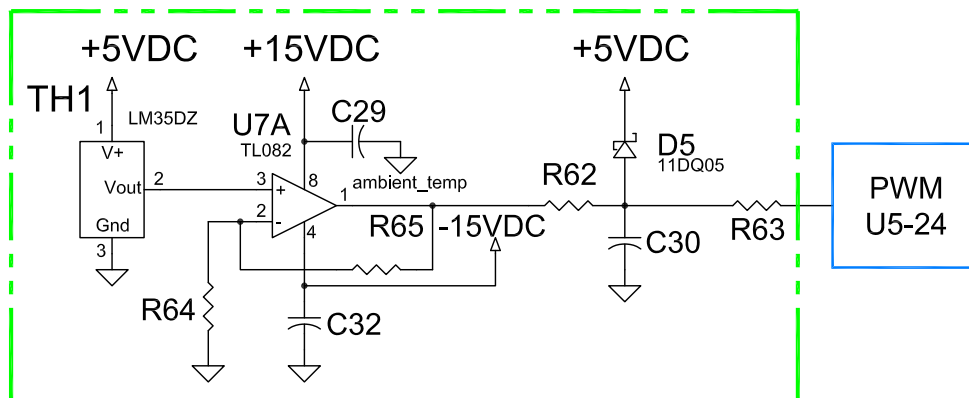

4.8.12 PCB1_I/O (0558038317)

The control board sends and receives signals across the two ribbon cables connecting the Main Control board to the Power Board. These two ribbon cables connected to the Main Control Board at J1 and J2 are the I/O bus of the unit.

Control board J1 connects to Power board J4
 Control board J2 connects to Power board J7

The inputs and outputs are described in the chart below.

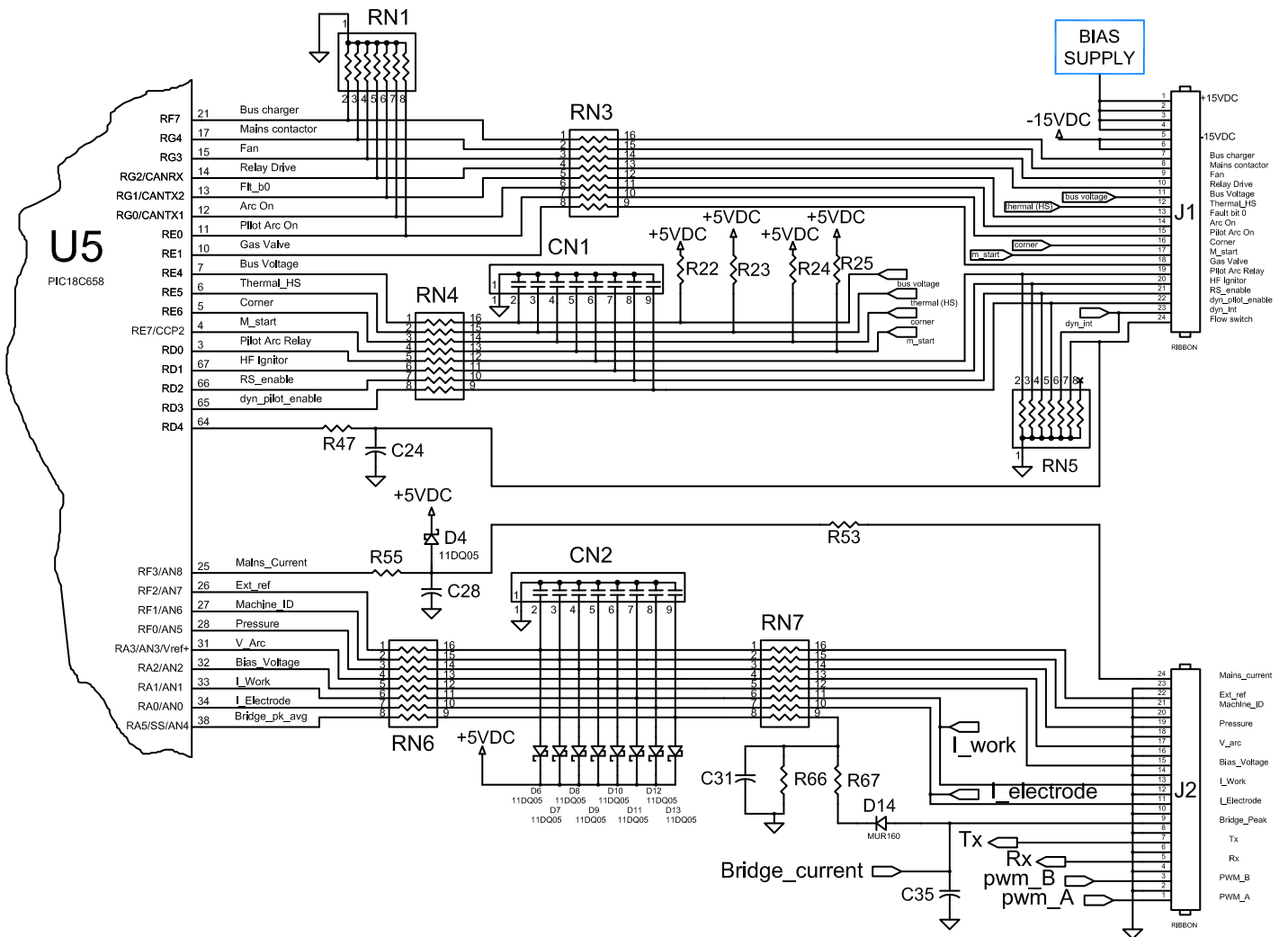

4.8.12 PCB1_I/O (0558038317)

J1 I/O Values		
Signal	Pin	Value
+15 VDC	1	+15 VDC
+15 VDC	2	
+15 VDC	3	
+15 VDC	4	
-15 VDC	5	-15 VDC
-15 VDC	6	
Bus Charger	7	Closes the Bus Charger Relay K1 on the Power Board PCB2
MainsContactor	8	Closes the Mains Contactor Relay RL3 on the Power Board PCB2
Fan	9	Closes the Fan Relay RL2 on the Power Board PCB2
NONE	10	NOT USED
	11	Output Inductor Thermal Switch TS2
Thermal HS	12	Heat Sink Thermal Switch TS1
Fault Bit 0	13	Fault bit output to CNC
Arc On	14	Arc On signal to the CNC
Pilot Arc On	15	Pilot Arc On signal to the CNC
Corner	16	
M_Start	17	Torch Switch input
Gas Valve	18	Turns on the Gas Valve Relay RL1 on the Power Board PCB2

4.8.13 PCB1_Microcontroller U5 (0558038317)

The Microcontroller on the Main Control Board contains the programming necessary to run the PC1600. Here the unit receives signals from the power board– (Start signal, current reference, Pilot Arc level ...) and acts upon them so as to get the plasma console to operate. Based on the input signals the microcontroller will generate output signals to turn on the contactors, relays and pulses required to make the unit function. The microcontroller also generates error messages and drives the front panel display. The Microcontroller is not user programmable. Should a problem arise with the microcontroller or the Main Control board, we recommend replacing the PCB.

4.8.14 PCB1 Layout (0558038317)

CONTROL/DISPLAY BOARD ASSEMBLY

P/N 0558038317

Before installation:

1. Disconnect input power to machine.
2. Verify position of dip switches.

Settings:

1. Verify SW2 - 1,2 dip switches are in the "open" position for proper operation.
2. Set SW1-1 dip switch for desired air pressure units of measure.
 - PSI - "OPEN"
 - BAR - Not Open
3. SW1-2 is not used.

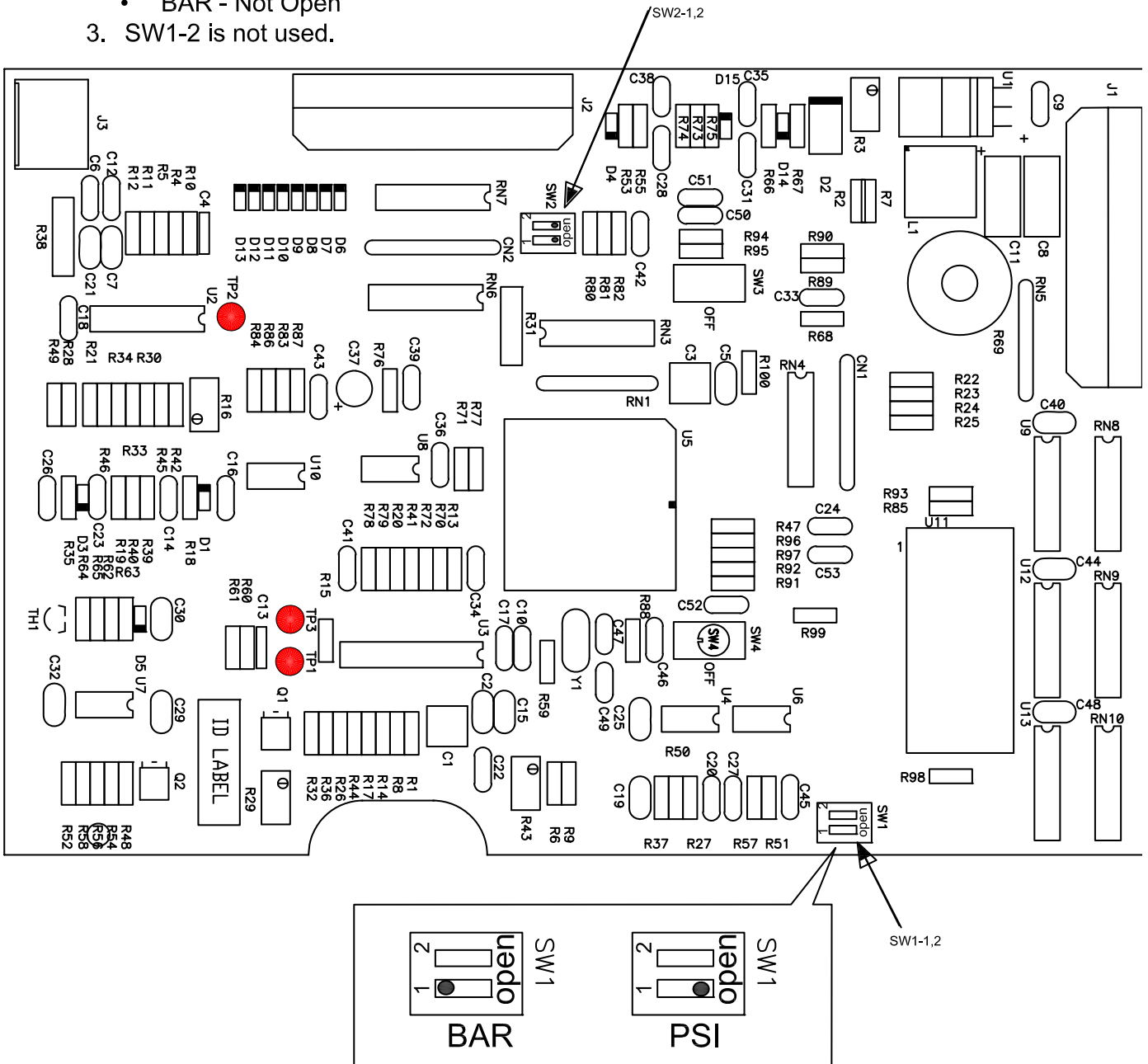

SECTION 4

DESCRIPTION OF OPERATION

4.8.15 PCB1 BOM (0558038317)

PCB1 COMPONENTS			
ITEM	QTY	DESCRIPTION	SYMBOL
1	1	DRILLED BOARD	
2	2	CAP, NET. 9 PIN SIP, 0.01uF	CN1,CN2
3	2	CAP, 4.7uF, 50VDC, ALUM	C1,C3
4	13	CAP, 0.22uF, 100VDC, CER	C2,C5,C7,C15,C19,C21,C25,C29, C30,C32,C40,C44,C48
5	2	CAP, 0.0068uF, 100VDC, MET-POLY	C4,C13
6	12	CAP, 0.01uF, 100VDC, FILM	C6,C17,C18,C23,C24,C31,C41,C4 2,C50,C51,C52,C53
7	2	CAP, 120uF, 25VDC, ALUM, ELECT.	C8,C11
8	9	CAP, 0.1uF, 100VDC, FILM	C9,C20,C22,C27,C28, C33,C36,C43,C45
9	4	CAP, 0.001uF, 100VDC, FILM	C10,C14,C35,C46
10	2	CAP, 0.022uF, 100VDC, CER	C12,C16
11	3	CAP, 560pF, 63VDC, MET-POLY	C26,C34,C39
12	1	CAP, 47uF, 35VDC, ELECT.	C37
13	3	CAP, 27pF, 300VDC, MICA	C38,C47,C49
14	2	DIODE, ZENER, 5.6V, 1N4734A	D1,D15
15	1	DIODE, SCHOTTKY, 31DQ05	D2
16	11	DIODE, SCHOTTKY, 11DQ05	D3,D4,D5,D6,D7,D8,D9,D10,D11, D12,D13
17	1	DIODE, MUR160	D14
18	2	HEADER, HORIZ. RIBBON, 24 PIN	J1,J2
19	1	HEADER, HORIZ, AMP, 5 PIN	J3
20	1	INDUCTOR, 115uH, PE53820	L1
21	2	TRANSISTOR, FET, IRLD014	Q1,Q2
22	2	RES, NET. 8 PIN SIP, 10K	RN1,RN5
23	1	RES, NET. 16 PIN DIP, 47	RN3
24	5	RES, NET. 16 PIN DIP, 470	RN4,RN6,RN8,RN9,RN10
25	1	RES, NET. 16 PIN DIP, 1K	RN7
26	4	RES, 10, .25W, 1%	R1,R15,R71,R76
27	1	RES, 2.8K, .25W, 1%	R2
28	1	RES, TRIMPOT, 500	R3
29	28	RES, 1K, .25W, 1%	R4,R7,R11,R12,R14,R17,R20,R22 ,R23,R24,R25,R28,R30,R37,R45, R50,R51,R57,R58,R83,R85,R86, R89,R90,R91,R92,R93,R98

SECTION 4**DESCRIPTION OF OPERATION****4.8.15 PCB1 BOM (0558038317)**

PCB1 COMPONENTS			
ITEM	QTY	DESCRIPTION	SYMBOL
30	8	RES, 10K, .25W, 1%	R5,R19,R52,R59,R73,R78,R84,R87
31	10	RES, 4.99K, .25W, 1%	R6,R18,R35,R36,R39,R40,R46,R48,R49,R64
32	16	RES, 499, .25W, 1%	R8,R13,R47,R53,R55,R62,R63,R68,R72,R75, R79,R88,R94,R95,R96,R97
33	2	RES, 15K, .25W, 1%	R9,R74
34	1	RES, 4.02K, .25W, 1%	R10
35	2	RES, TRIMPOT, 1K	R16,R29
36	1	RES, 11.5K, .25W, 1%	R21
37	1	RES, 6.65K, .25W, 1%	R26
38	2	RES, 2.49K, .25W, 1%	R27,R56
39	2	RES, 250, 1W, .1%	R31,R38
40	7	RES, 100, .25W, 1%	R32,R41,R67,R70,R77,R99,R100
41	1	RES, 499K, .25W, 1%	R33
42	1	RES, 158, .25W, 1%	R34
43	1	RES, 9.53K, .25W, 1%	R42
44	1	RES, TRIMPOT, 10K	R43
45	1	RES, 6.19K, .25W, 1%	R44
46	5	RES, 20K, .25W, 1%	R54,R65,R80,R81,R82
47	3	RES, 49.9K, .25W, 1%	R60,R61,R66
48	1	RES, VARIABLE, 10K	R69
49	2	SWITCH, DIP	SW1,SW2
50	2	SWITCH, SPDT/CENTER OFF	SW3,SW4
51	1	THERMAL SENSOR, LM35DZ	TH1
52	3	TEST POINT	TP1,TP2,TP3
53	1	I.C. REGULATOR, LM2595-ADJ	U1
54	1	I.C. QUAD OP-AMP, MC3403	U2
55	1	I.C. PWM, UC3526A	U3
56	2	I.C. 10 BIT DAC, MAX5354	U4,U6
57	1	SOCKET	U5
58	1	I.C. DUAL OP-AMP, TL082	U7
59	1	I.C. DRIVER, MIC4420	U8
60	3	I.C. ,LED DRIVER, A6275EA	U9,U12,U13
61	1	I.C. COMPARATOR, LM311N	U10
62	1	I.C. DIGITAL DISPLAY	U11
63	1	CRYSTAL, 8MHz	Y1
64	1	SOCKET	U11S

4.9 Input Inductor L1 (0558007149 / / 0558007151)

0558007149 Input Inductor L1

The Input Inductor L1 is a line reactor inductor used to filter out line noise in the 400 and 575 VAC units. This is a three gang unit of three 170 micro-Henrys capable of passing 22 amps of current.

0558007151 Input Inductor

The Input Inductor L1 is a line reactor inductor used to filter out line noise in the 230 and 460 VAC units. This is a 300 micro-Henry, 150 Amp unit.

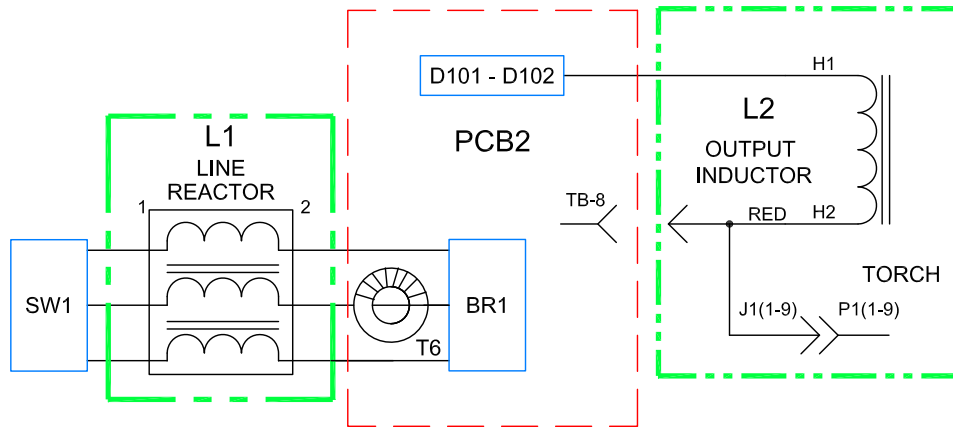

Input Inductor 0558007149

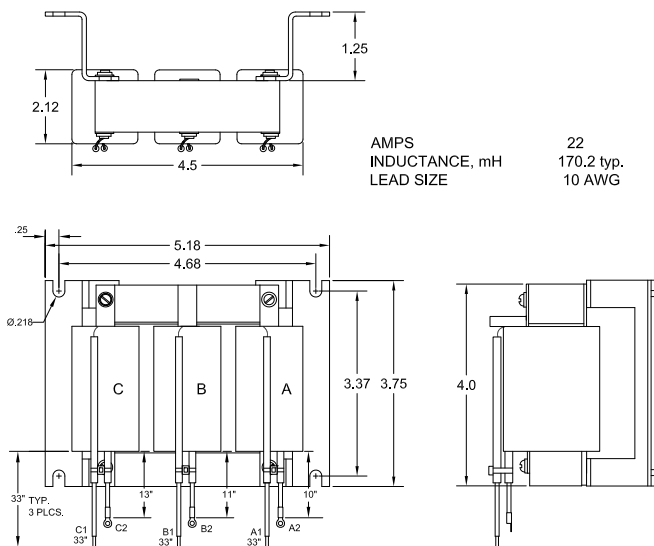

Input Inductor 0558007151

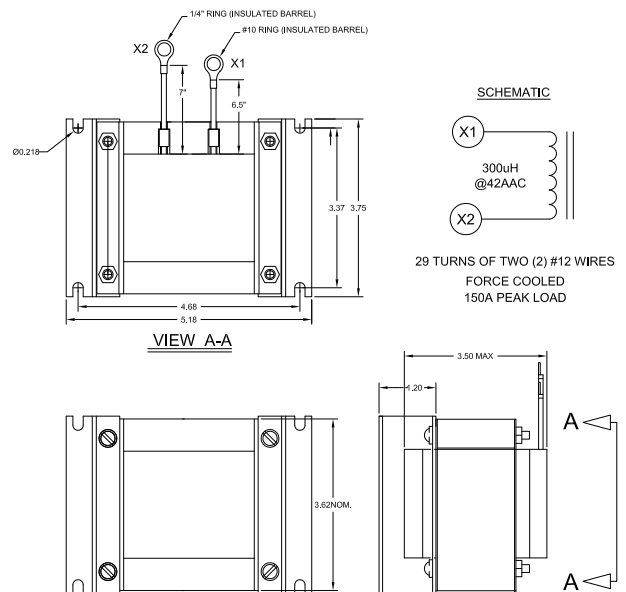

4.9.1 Output Inductor (0558007152)

The output inductor L2 is used to filter the DC output of the PC1600.

The inductor is a 600 micro Henry unit designed to resist changes in the output of the PC1600.

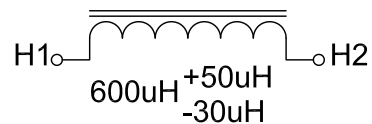
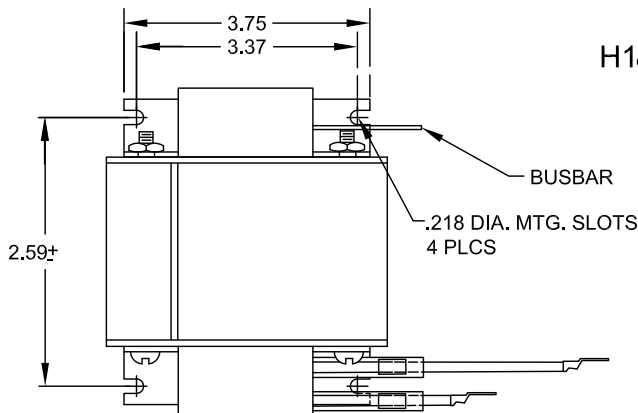
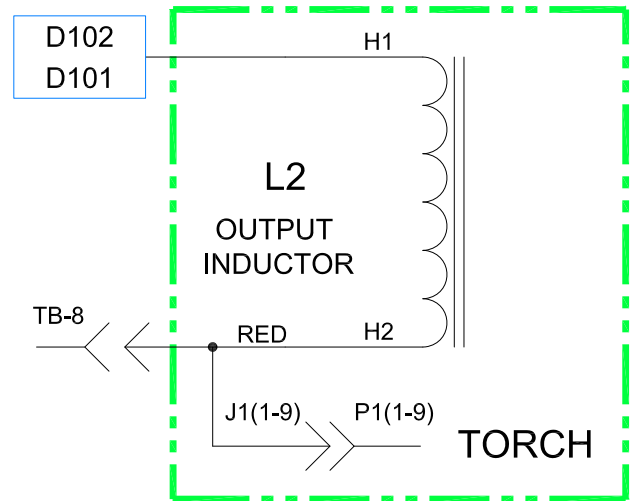

CURRENT: 60 AMPS
 INDUCTANCE:
 600uH @60ADC (+50uH, -30uH)
 NO. OF TURNS: 30T (REF.)
 • LEAD LENGTH TOLERANCE
 ±.5 UNLESS NOTED
 OTHERWISE

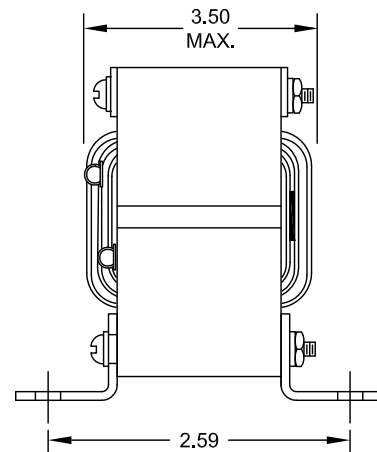
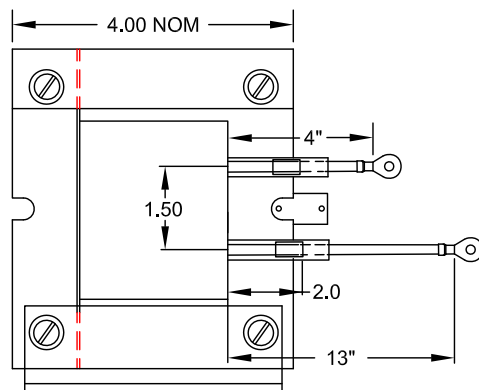

4.10 Power PC Board (0558038315)

The power board in the PC1600 allows the power connections to be made in a solid, central way that makes short power runs with hi power carrying capacity. All of the power carrying components are mounted to PCB2.

SECTION 4

DESCRIPTION OF OPERATION

4.10.1 Power PC Board Schematic (0558038315)

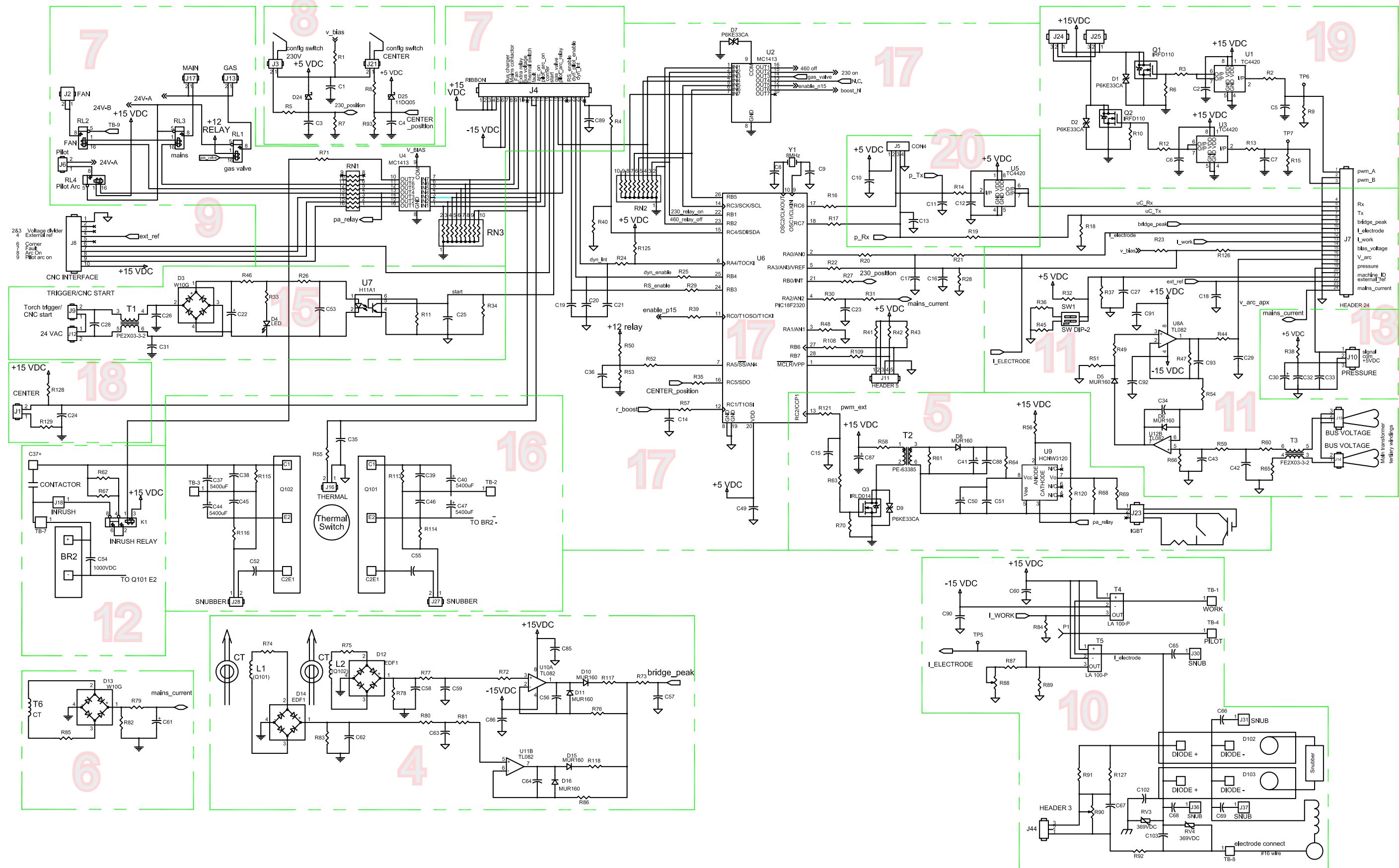

4.10.2 Power PC Board Schematic 2 (0558038315)

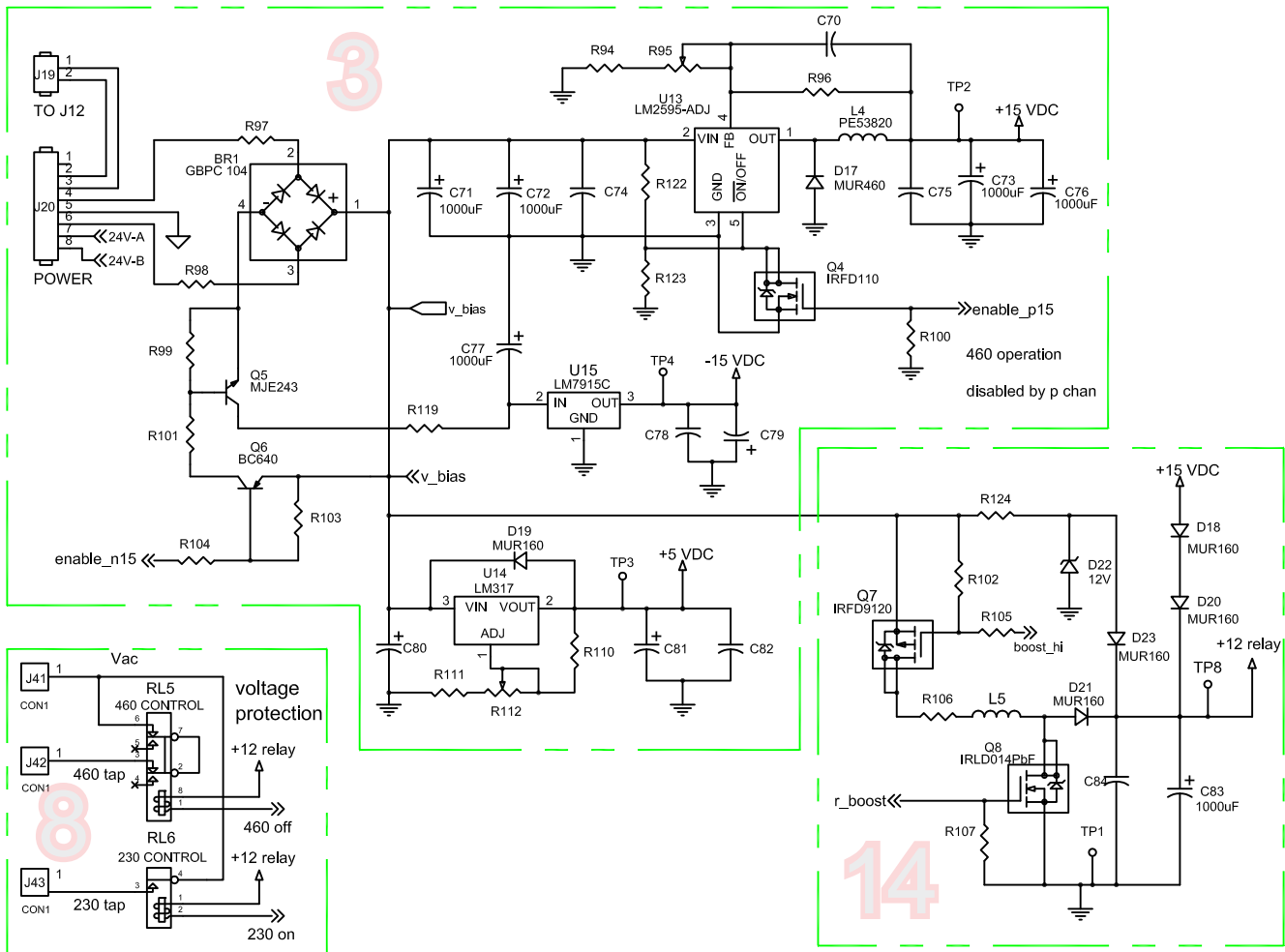

4.10.3 Power Board_PCB2 Bias Supply Circuit (0558038315)

The Bias supply circuit provides the power necessary to operate the onboard circuitry of the PC1600. This section provides three output voltages to the unit; +15VDC, -15VDC and +5 VDC.

Two 18 VAC inputs are applied to the board at J20 Pins 4, 5 and 6, With pin 5 being the grounded center tap off the transformer.

This AC power is applied to a full wave rectifier, BR1 where it is converted to a pulsing 25 VDC. This pulsing DC is then filtered and passed to the regulator circuits.

The positive 15 VDC supply is filtered by C71 and C72, a pair of 1000 mfd capacitors. This power is then connected to a five pin adjustable voltage regulator, U13. Output voltage is set by the voltage divider comprised of R94, R95 and R96. Pin 4 of the voltage regulator is connected to R95 a 500 trim pot that is used to adjust the output voltage of the regulator. Output power is turned on or off by turning on the mosfet Q4. When Q4 is forward biased, the Mosfet conducts and places a low on pin 5 of the regulator U13. The Q4 MOSFET is turned on by the microcontroller on the Power Board PCB2.

Power output from the regulator is filtered by C73 and C76, a pair of 1000 mfd capacitors, before being passed to the needed circuitry.

The Negative output of the rectifier bridge BR1 is connected to Q5, which acts as a series pass device. When Q5 is turned on, it allows power to be passed to the negative voltage regulator. Q5 is turned on when Q6 is conducting. Q6 is placed in conduction when the microcontroller passes the enable_n15 signal to the base of Q6. In this manner, the microcontroller on the Power Board can control the power supply. Once Q5 is turned on and passing current, the negative supply is filtered by C77, a 1000 mfd filter capacitor. This filtered output is then fed to U15 a three pin -15VDC regulator.

The +5vdc supply is fed from the positive filter section (C71 and C72) and connected to a three pin adjustable regulator U14. The output of this regulator is varied by R112 a 500 Ohm trim pot. This supply is always active whenever the machine is powered up.

4.10.3 Power Board_PCB2 Bias Supply Circuit (0558038315)

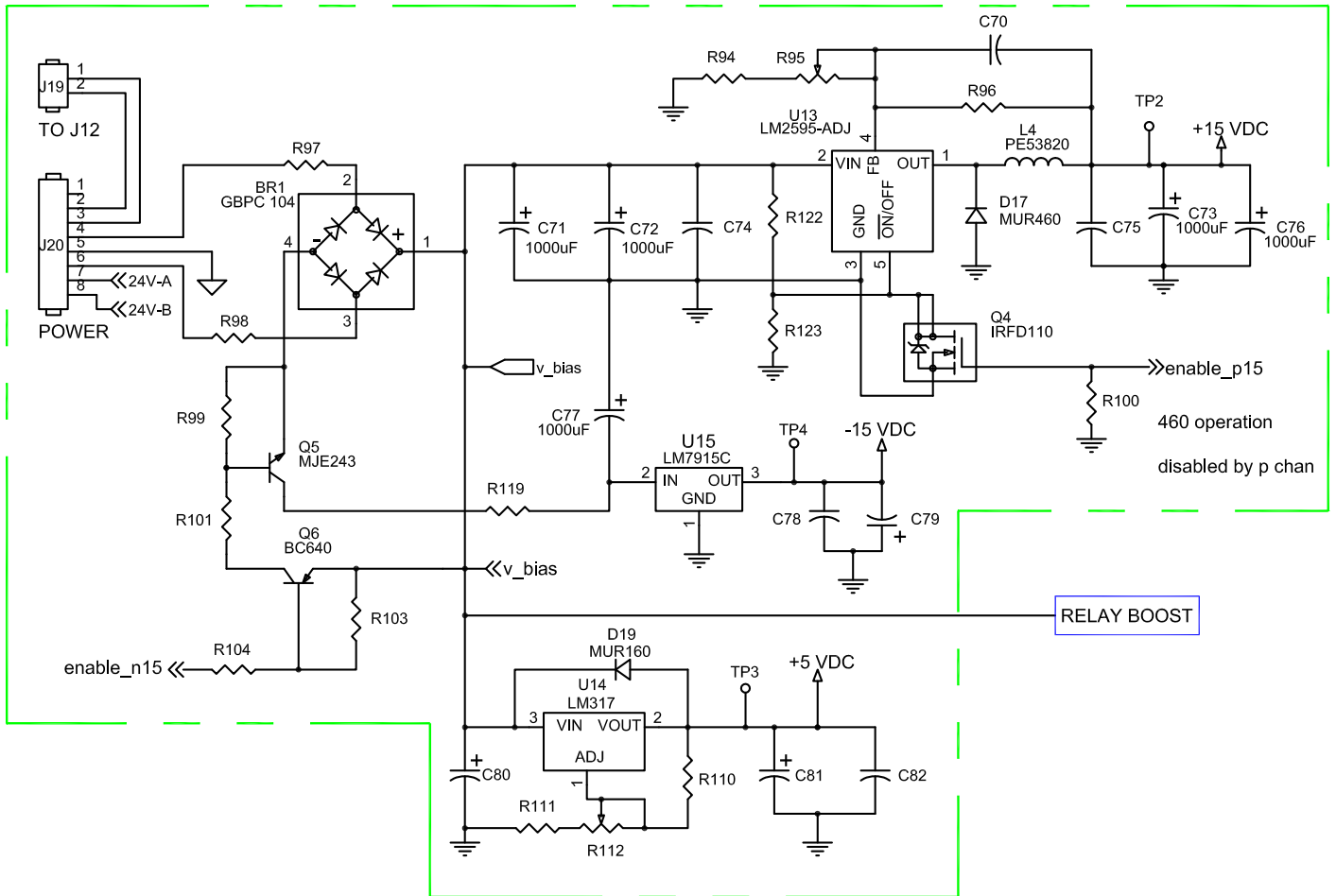

PCB2 BIAS SUPPLY TEST POINTS		
Test point	Reference Point	Value
TP2	TP1	+15VDC
TP3	TP1	+5VDC
TP4	TP1	-15VDC
J20 pin 4	J20 Pin 5	18 VAC
J20 pin 6	J20 Pin 5	18 VAC
J20 pin 4	J20 Pin 6	36 VAC

4.10.4 Power PC Board Over Current Protection (0558038315)

The power board uses a pair of current transformers to detect an over current condition on the output of the PC1600. In the event the output exceeds the rated current, the induced signal in the transformers shuts down the power circuit at the control board microcontroller.

The output from each of the IGBTs is passed to the output transformer through the Current Transformers L1 and L2. The output of these transformers is rectified and then connected to a buffering IC. When the output of this op amp exceeds the error threshold, the control board micro shuts down the PWM and sends an error to the display.

When the PC1600 is operating, current flowing out of Q101 to the output transformer flows through a wire that passes through the Current Transformer L2. The expanding and contracting magnetic field of the wire induces a voltage in the Current Transformer. The output of this transformer is connected to a full wave bridge, D12, where it is rectified and passed to op amp U10A on pin 3 for buffering. The output of U10A on pin 1 passes through D10 and is sent to the main control board PCB1 as signal bridge_peak. When this voltage exceeds 2.75 VDC the main control board PCB1 will shut down the PWM and send an error to the display.

When the PC1600 is operating, current flowing out of Q102 to the output transformer flows through a wire that passes through the Current Transformer L1. The expanding and contracting magnetic field of the wire induces a voltage in the Current Transformer. The output of this transformer is connected to a full wave bridge, D14, where it is rectified and passed to op amp U11B on pin 5 for buffering. The output of U11B on pin 7 passes through D15 and is sent to the main control board PCB1 as signal bridge_peak. When this voltage exceeds 2.75 VDC the main control board PCB1 will shut down the PWM and send an error to the display.

It should be noted that the 2.75 VDC is the greater of the two outputs of the current transformers. If either one of them puts out a signal greater than 2.75 volts DC, the PWM circuit will shut down. These two signals are compared and the greater of the two is present at R73 before passing to the main control board.

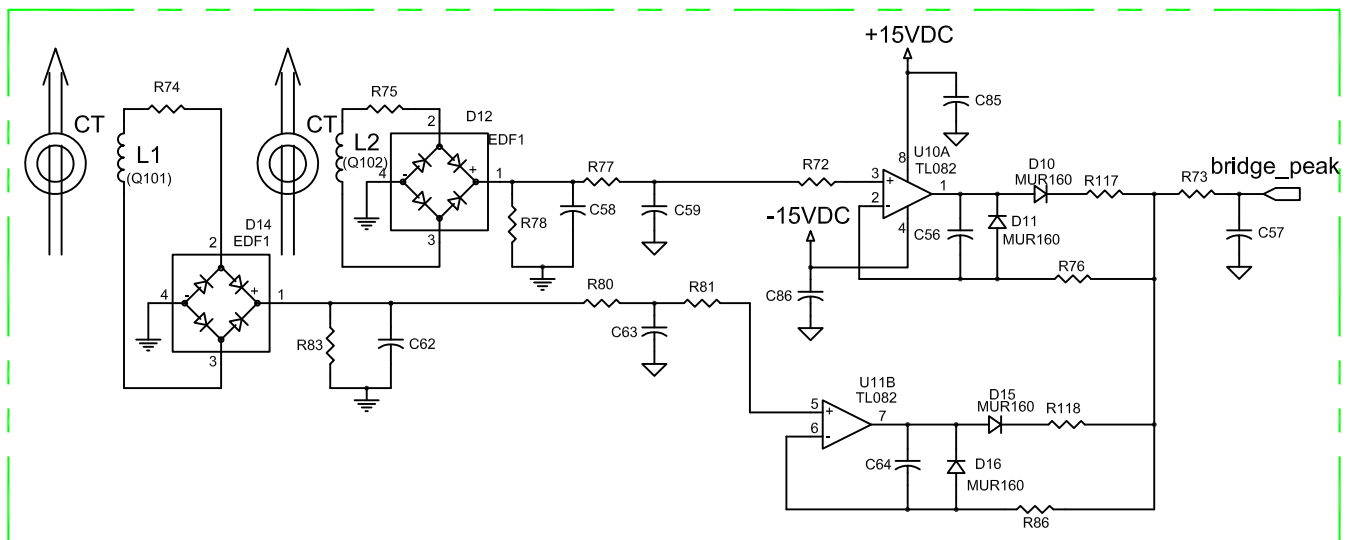

4.10.5 Power PC Board_Pilot Arc / IGBT Driver Circuit (0558038315)

The Pilot Arc IGBT is gated on from the Main Power board PCB-2 via an IC on the power board. The Pilot Arc IGBT is gated on from U9 Pin 7. This output is enabled when the microcontroller toggles on the PA relay signal to U9 pin 3. This places a high on U9 pin 7 that forward biases the Pilot Arc IGBT, through the pilot arc driver board PCB-5.

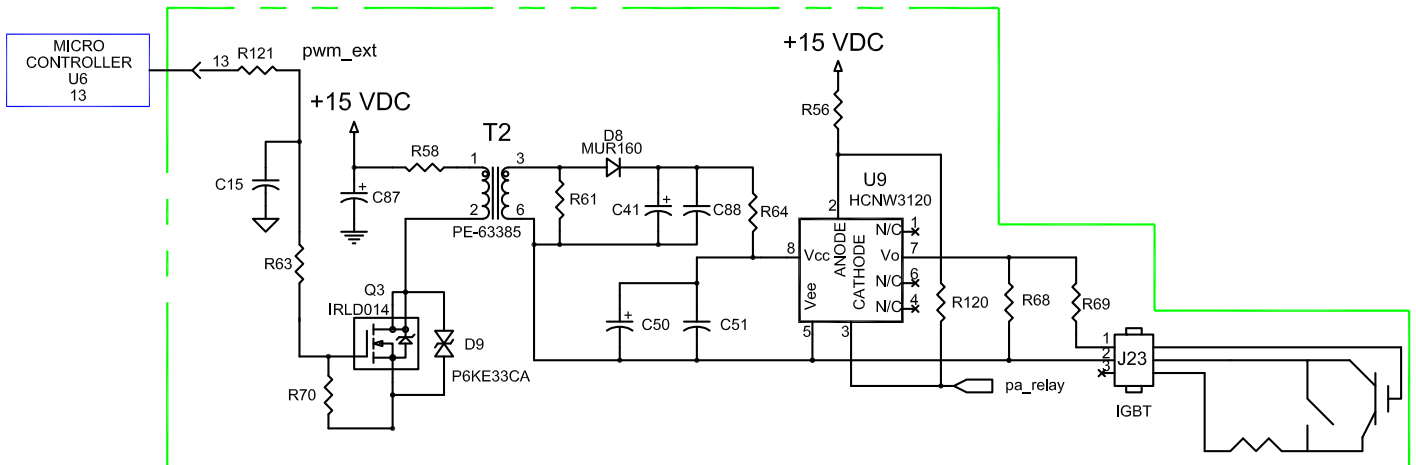

4.10.6 Power PC Board Single Phase Detection (0558038315)

The power board monitors the the input power for loss of a phase when in three phase operation. This is important as the microcontroller monitors the output duty cycle of the machine. The PC1600 is rated for 60% duty cycle at 90 amps of output current in three phase operation, and 40% duty cycle at 90 amps of output current in single phase operation. Should the unit exceed the duty cycle, the microcontroller will shut the machine down when the duty cycle limit is reached to prevent damage to the machine.

The single phase detection circuit monitors the output of T6. The AC voltage here is rectified by full wave bridge D13. The output is then filtered by C61 and passed to the power board microcontroller as signal mains_current.. A loss of voltage at T6 results in the loss of the mains_current signal. This loss tells the micro control that the unit has lost a power input phase.

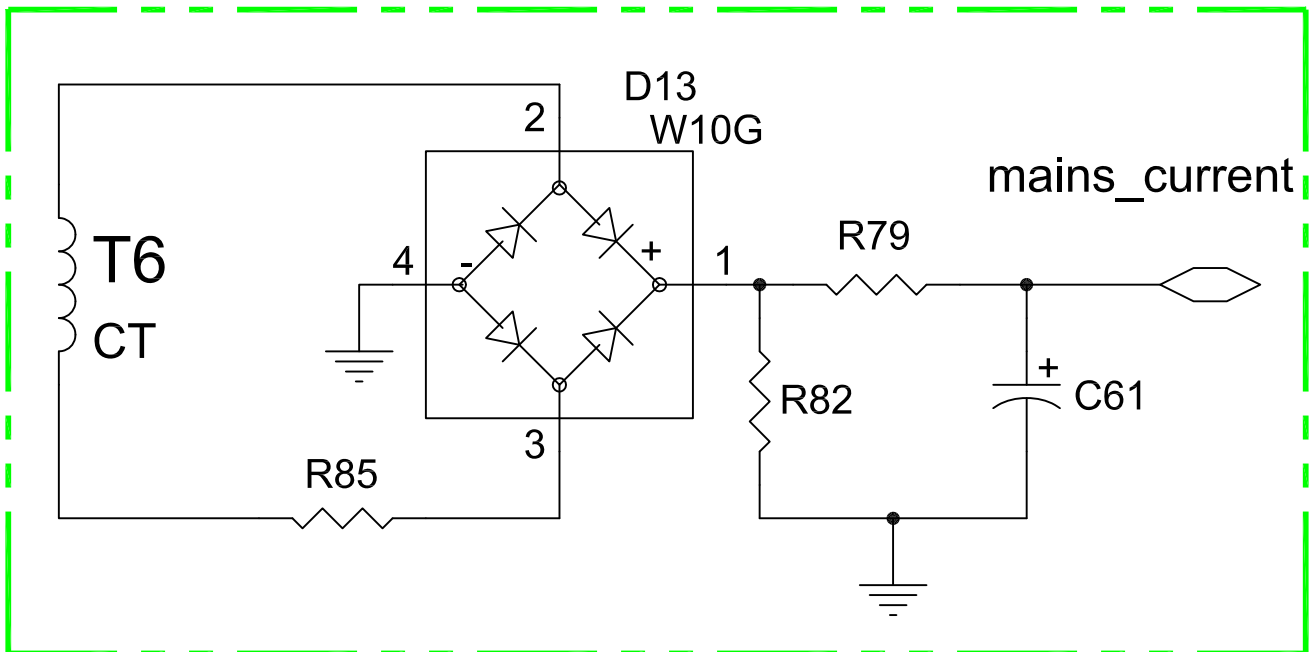

4.10.7 Power Board_PCB2 Control Relays (0558038315)

The Power Board has seven relays mounted on it. One is used as part of the Inrush circuit, and will be discussed there (See section 4.10.12, Inrush circuit)

The remaining relays RL1 – RL4, control other functions of the PC1600.

RL1 is the gas solenoid control relay. This relay is closed when the unit is commanded to flow air for pre-flow, cutting operations and postflow. The signal used to close this relay comes from the control board.

RL2 is the fan relay. The fan relay closes when the unit begins a cutting operation. The fan will run as long as the unit is cutting and will continue to run for seven and a half minutes after the unit has ceased cutting. The signal used to close this relay comes from the control board.

RL3 is the main contactor relay. This relay closes the main contactor during cutting operations. The signal used to close this relay comes from the control board.

RL4 – not used at this time

RL5 460 Off relay. This relay opens when 460 volts AC is NOT the input voltage

RL6 230 On relay. This relay closes when 230 VAC IS the input voltage.

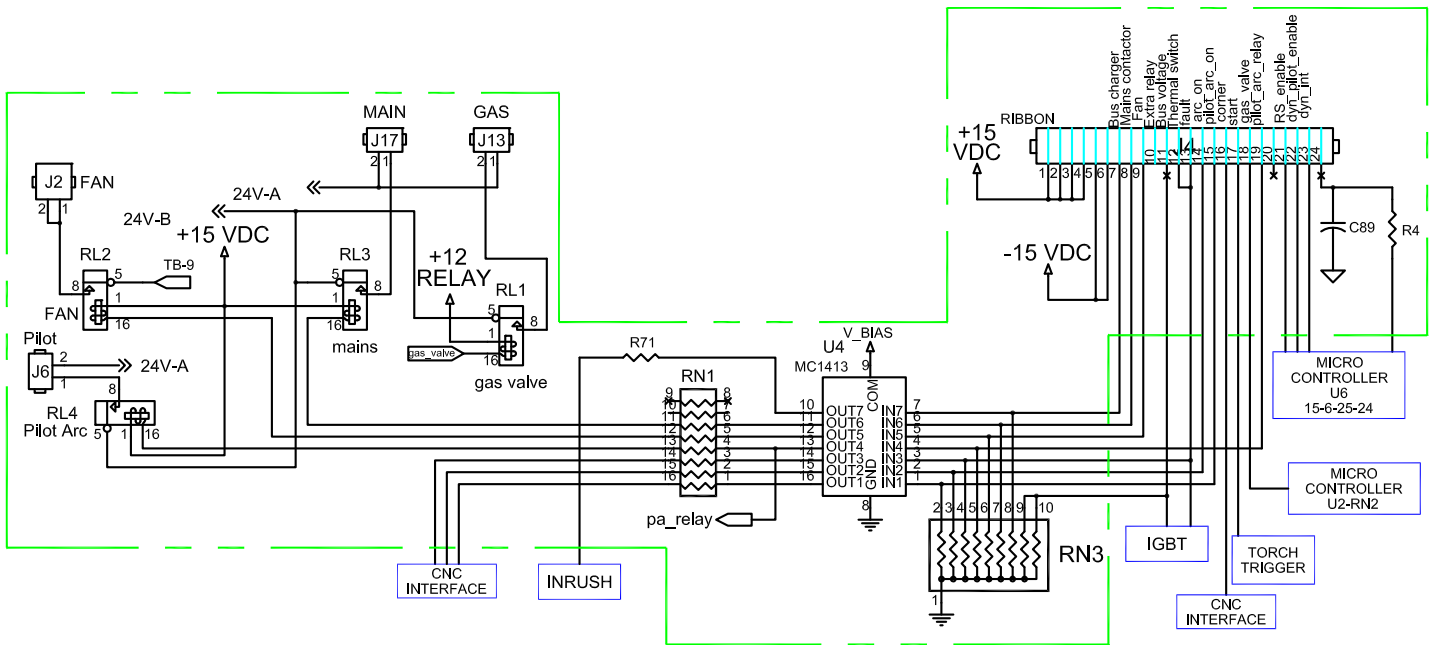

4.10.7 Power Board_PCB2 Control Relays (0558038315)

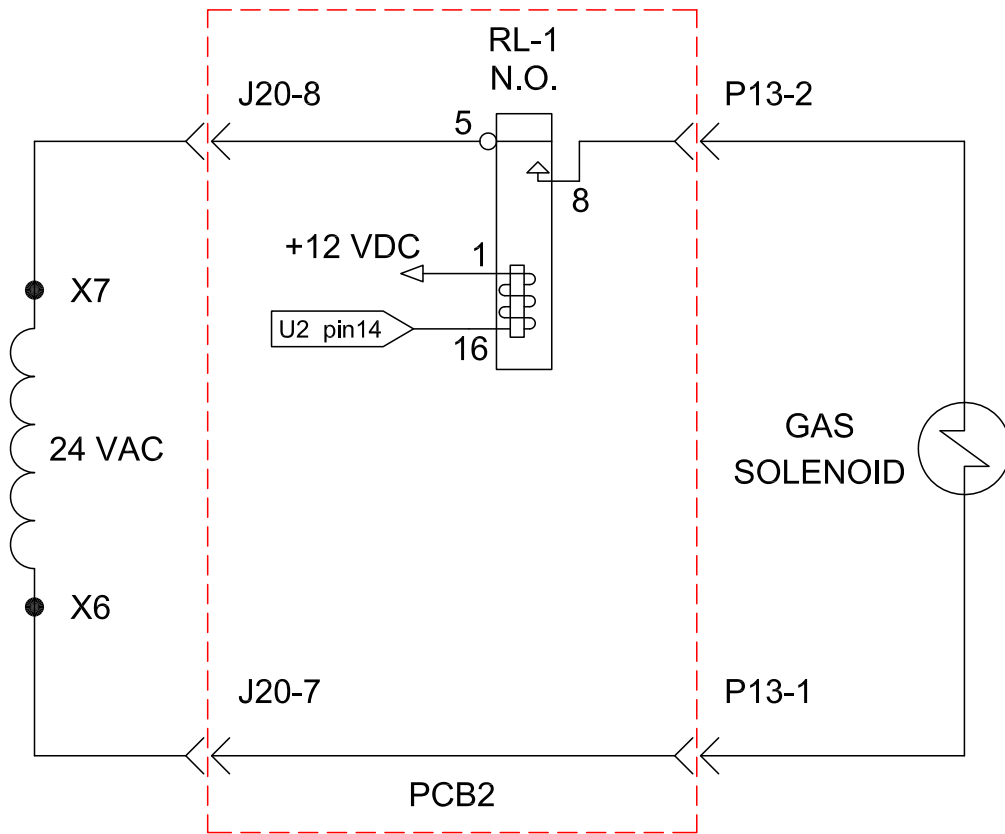

4.10.8 Power Board_PCB2 Voltage Selection Circuit (0558038315)

The input voltage selection is controlled by the, manually set, position of S2 however the voltage selection circuit on the power board will tell the power board micro-controller that the input power is 230 or any other voltage. This allows the power board to render some protection against major damage should the incorrect voltage be applied. Two relays, RL5 and RL6 provide the logic for the micro based on signals from the input.

It is the combination of these two signals and the V bias signal that tells the power board micro controller to energize RL5 (the NOT 460 VAC relay) and RL6 (the 230 VAC relay). If the input power switch is changed during operation, this circuit will notify the microcontroller and the unit will be disabled until it is powered down and powered back up. If the input voltage is not correct (230 VAC applied while the input switch is in the 460 VAC position) the power board micro will not enable the systems +/- 15VDC bias voltages.

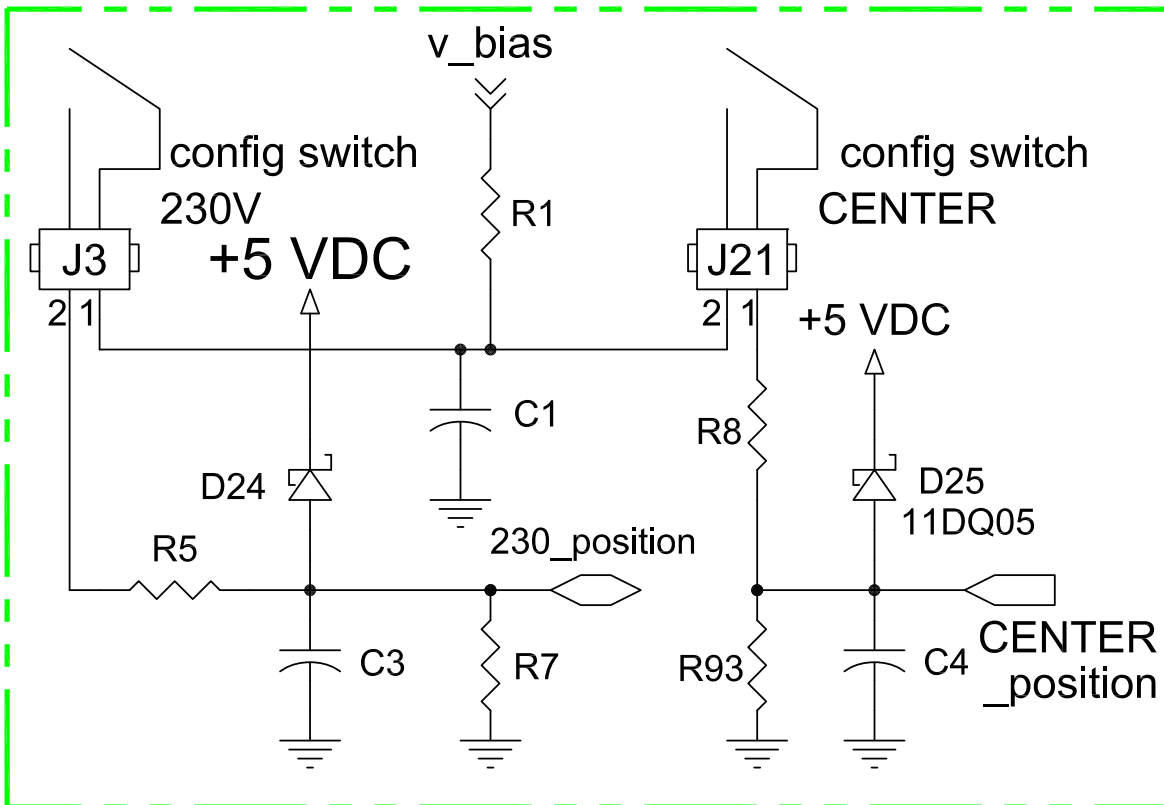

4.10.8 Power Board_PCB2 Voltage Selection Circuit (0558038315)

The input voltage selection is controlled by the, manually set, position of S2 however the voltage selection circuit on the power board will tell the power board micro-controller that the input power is 230 or any other voltage. This allows the power board to render some protection against major damage should the incorrect voltage be applied. Two relays, RL5 and RL6 provide the logic for the micro based on signals from the input.

It is the combination of these two signals and the V bias signal that tells the power board micro controller to energize RL5 (the NOT 460 VAC relay) and RL6 (the 230 VAC relay). If the input power switch is changed during operation, this circuit will notify the microcontroller and the unit will be disabled until it is powered down and powered back up. If the input voltage is not correct (230 VAC applied while the input switch is in the 460 VAC position) the power board micro will not enable the systems +/- 15VDC bias voltages.

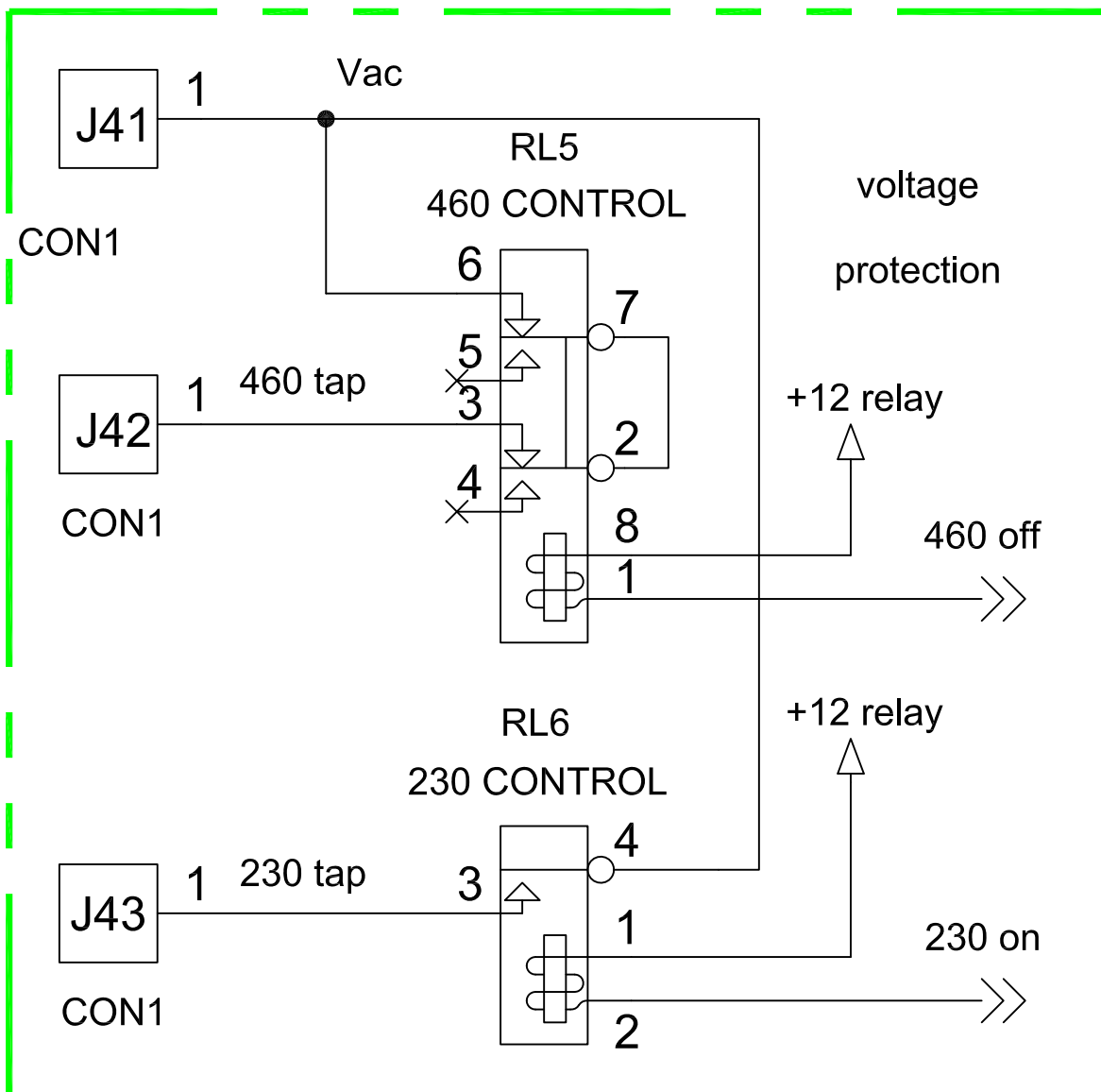

4.10.9 Power Board_PCB2 CNC Interface (0558038315)

The PC1600 is designed to be used in a mechanized environment. The CNC interface connector J8 is used to connect to the Remote board PCB6, which will interface with a CNC via the J2 Amphenol plug. The J8 connector passes all signals but one, the external reference signal, to the main control board PCB1 through the PCB2 J4 - PCB1 J1 ribbon cable. The external reference signal, used to set the output current of the PC1600 remotely, is connected to the main control board through the PCB2 J7 – PCB1 J2 ribbon cable.

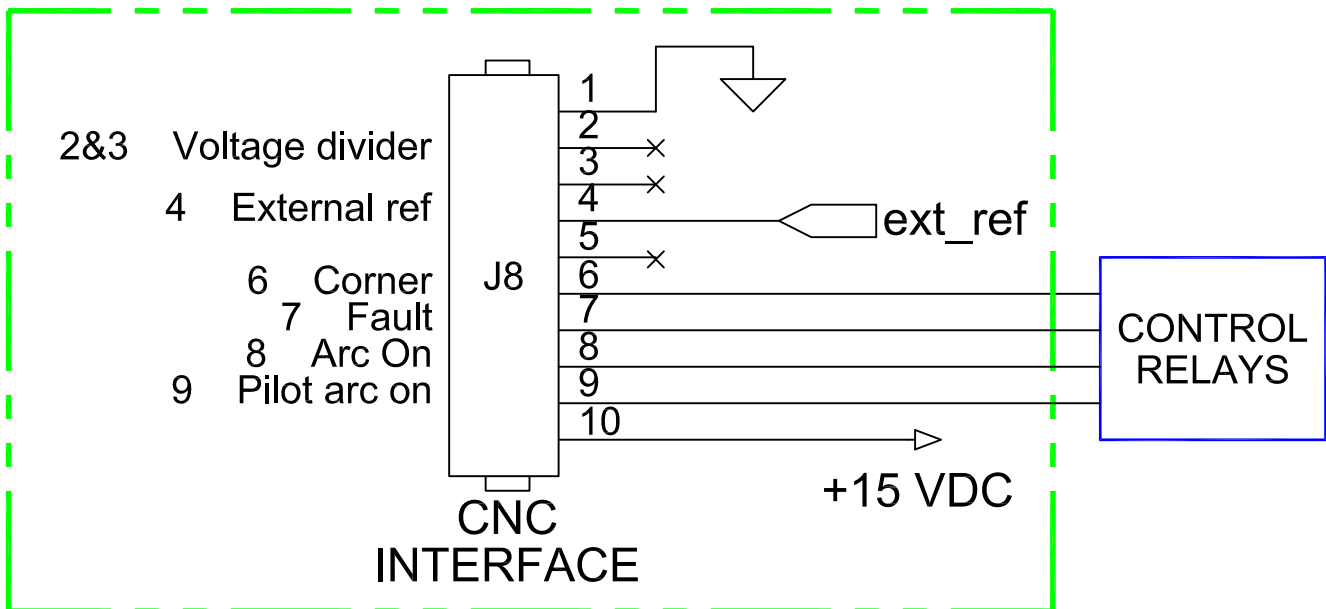

4.10.10 Power Board_PCB2 Output Circuit (0558038315)

The Output Circuit on the power board consists of the rectifier diodes, the snubber, the output inductor and a pair of Hall sensors.

The output diodes D103 and 104 are connected directly to the power board. AC Power from the output transformer is connected to these two diodes at the negative terminals. This 18 KHz output is rectified to DC and then passed through the Hall sensors and out to the Electrode, Pilot Arc Lead and Work lead. The Hall devices sense the current level and send a current sense signal to the control board where it is used internally by the microprocessor and sent to the display board.

Hall sensor T5 detects torch and pilot arc current. Hall sensor T4 detects only the work current.

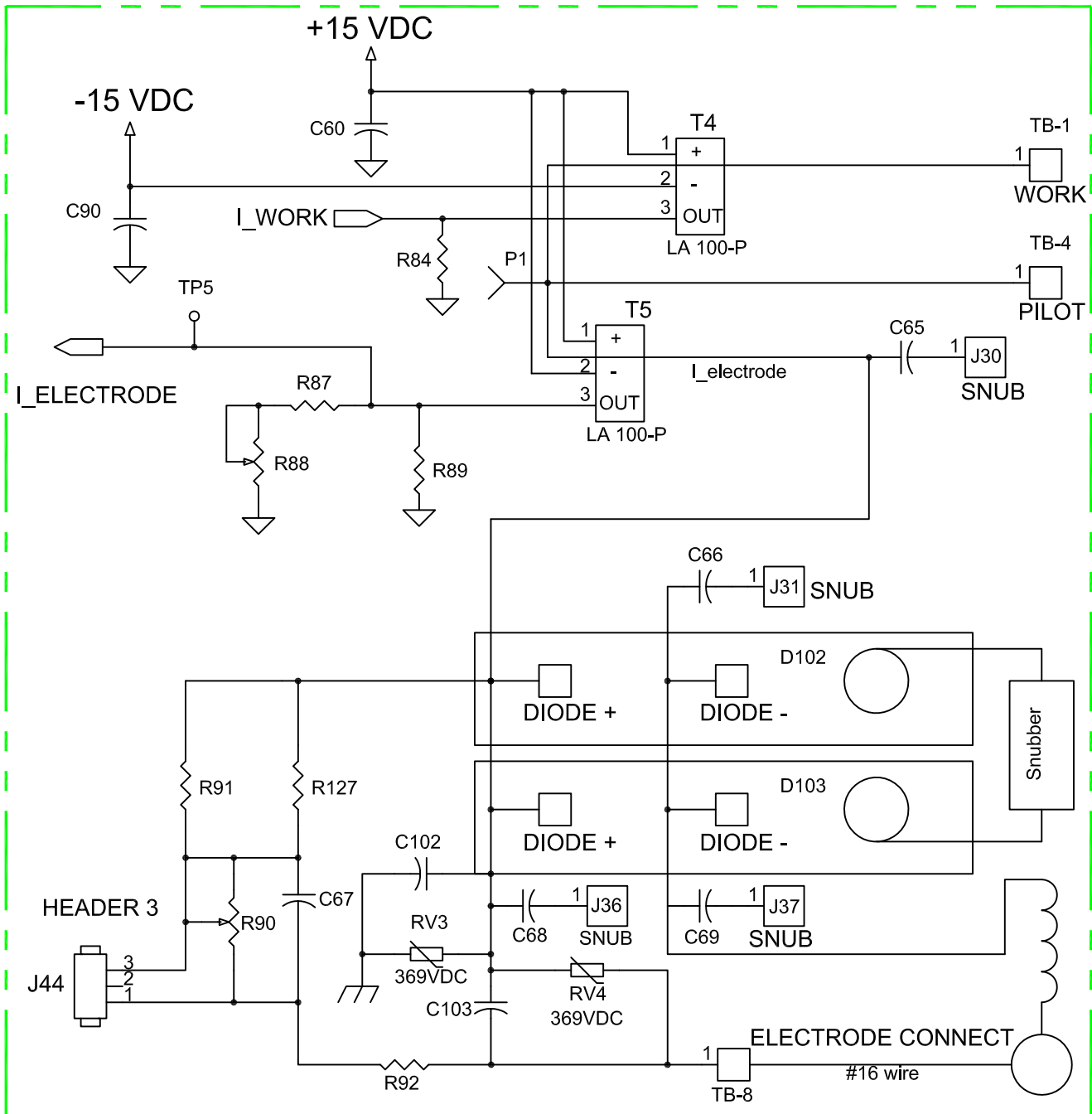

4.10.11 Power Board_PCB2 V-Arc Circuit (0558038315)

The V-Arc circuit is designed to notify the microcontroller on the Control board PCB1 of a low output voltage situation. Voltage input from the two tertiary windings is connected to the Power board PCB2. This square wave AC is divided and connected to an electronic rectifier that outputs a DC reference voltage that is connected to the Microcontroller of PCB1.

Voltage input on J14 and J15 from the tertiary windings of the main transformer are connected in phase and passed first through a Ferrite inductor before being connected across a voltage divider network. Once divided, the signal is connected to the non inverting input of U12b and passed out to a rectifier diode, D5. This output is divided again and connected to the non inverting input of U8A. This output is filtered by

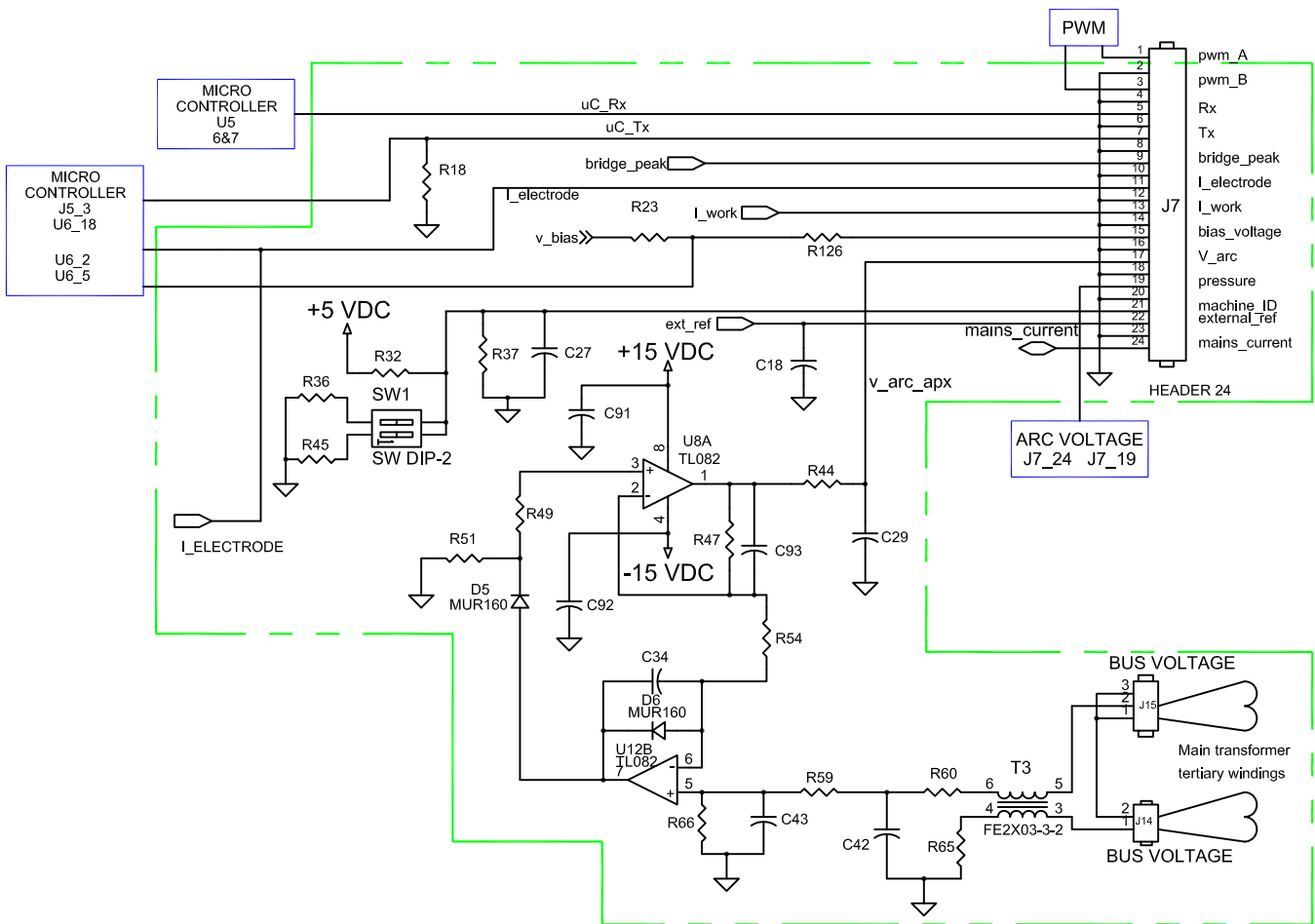

4.10.12 Power Board_PCB2 Inrush Circuit (0558038315)

The Inrush circuit is designed to allow the filter buss to charge up at a lower current level so that when the unit begins cutting the initial current draw does not cause an excessive current surge condition which could damage the unit.

When the on board relay K1 closes, the filter capacitors charge through the thermistors R62 and R67. These two thermistors restrict the amount of current drawn by the filter caps during their initial charge.

When the torch switch closes the control board PCB1 will then close the mains contactor K1 on the chassis to allow full output current to be drawn through the mains contactor.

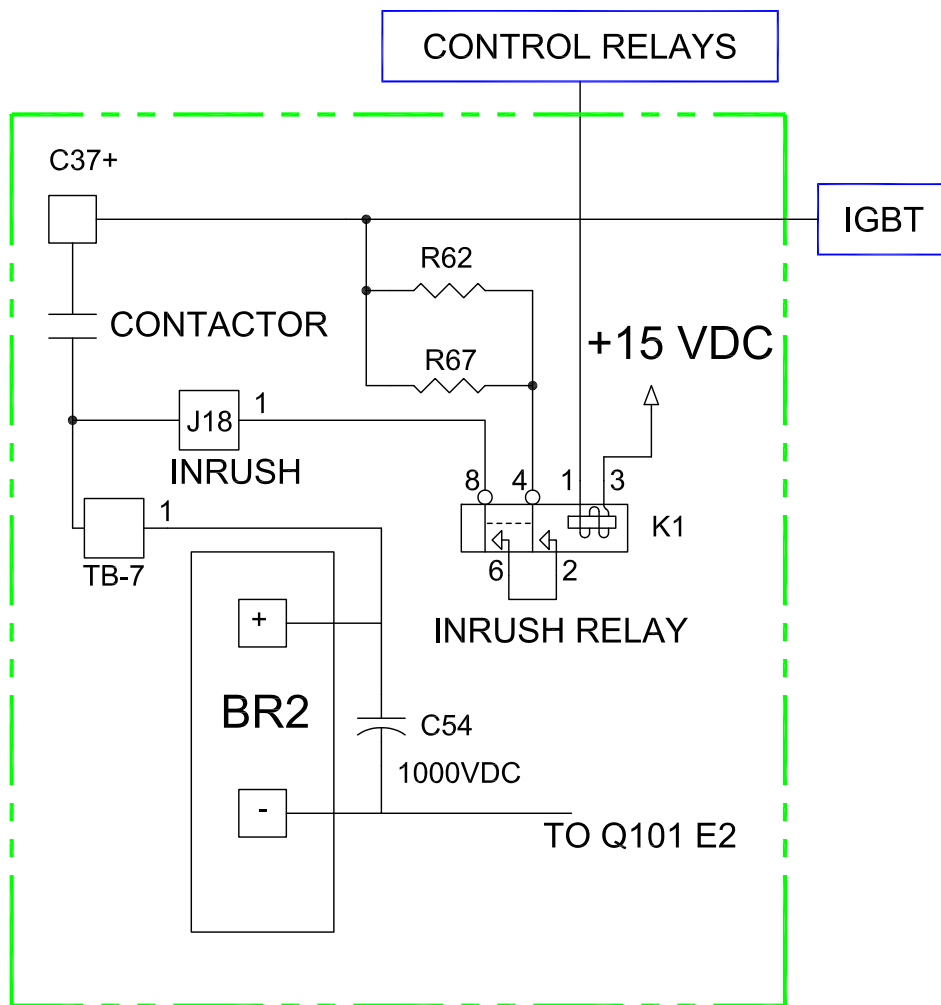

4.10.13 Power Board_PCB2 Pressure Transducer (0558038315)

The pressure transducer circuit provides the voltage to operate the pressure transducer and accepts the gas pressure signal back from the device. This signal is then passed to the Main Control board. The pressure transducer receives +5 volts DC across J10 pin 3 (+5 VDC) and pin 2 (DC common) The signal is returned from the transducer on pin 1. This signal is coupled to main control board on J7 pin 19 and ranges from 0.2 to 4.9 VDC. This is equal to 0 – 100 psi of input pressure.

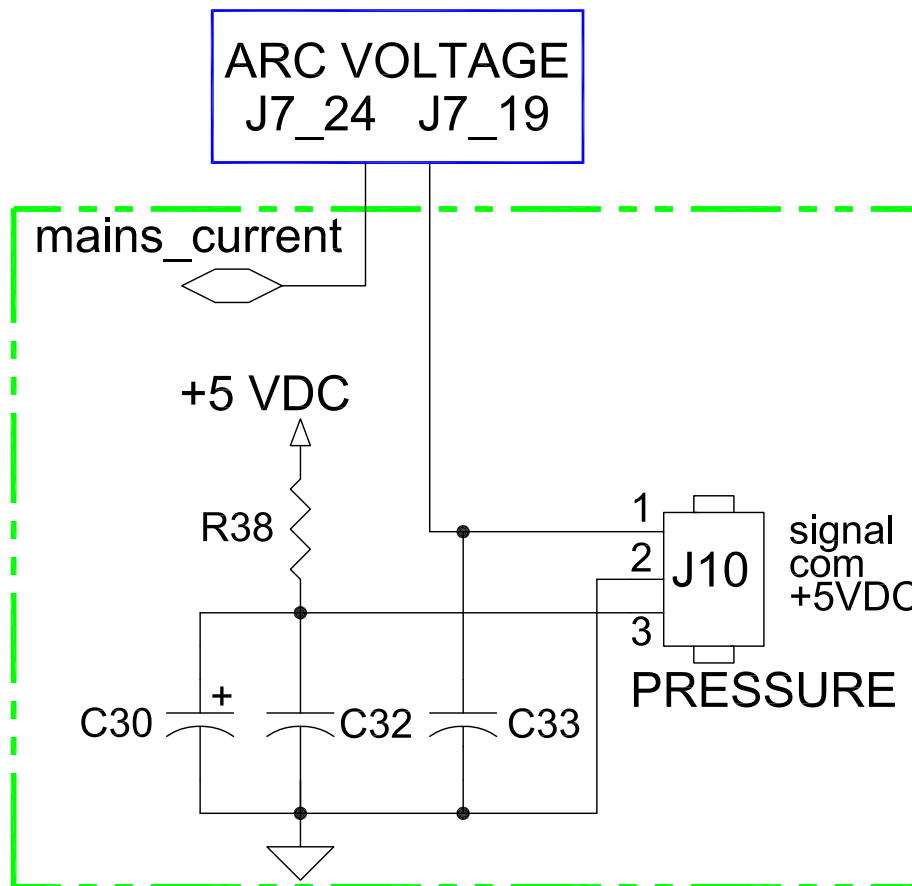

4.10.14 Power Board_PCB2 Relay Boost Circuit (0558038315)

The Relay Boost circuit provides a source of power to trip the source voltage relays in the event that the AC three phase input voltage is below 210 VAC in the 230 VAC mode.

In the event that the input power is low Q7 is turned on and conducts sending source voltage down to Q8. The microcontroller gates on Q8 with a series of pulses that charge C84 to approximately 14 VDC. This allows the 12 VDC relays to close in the voltage protection circuit.

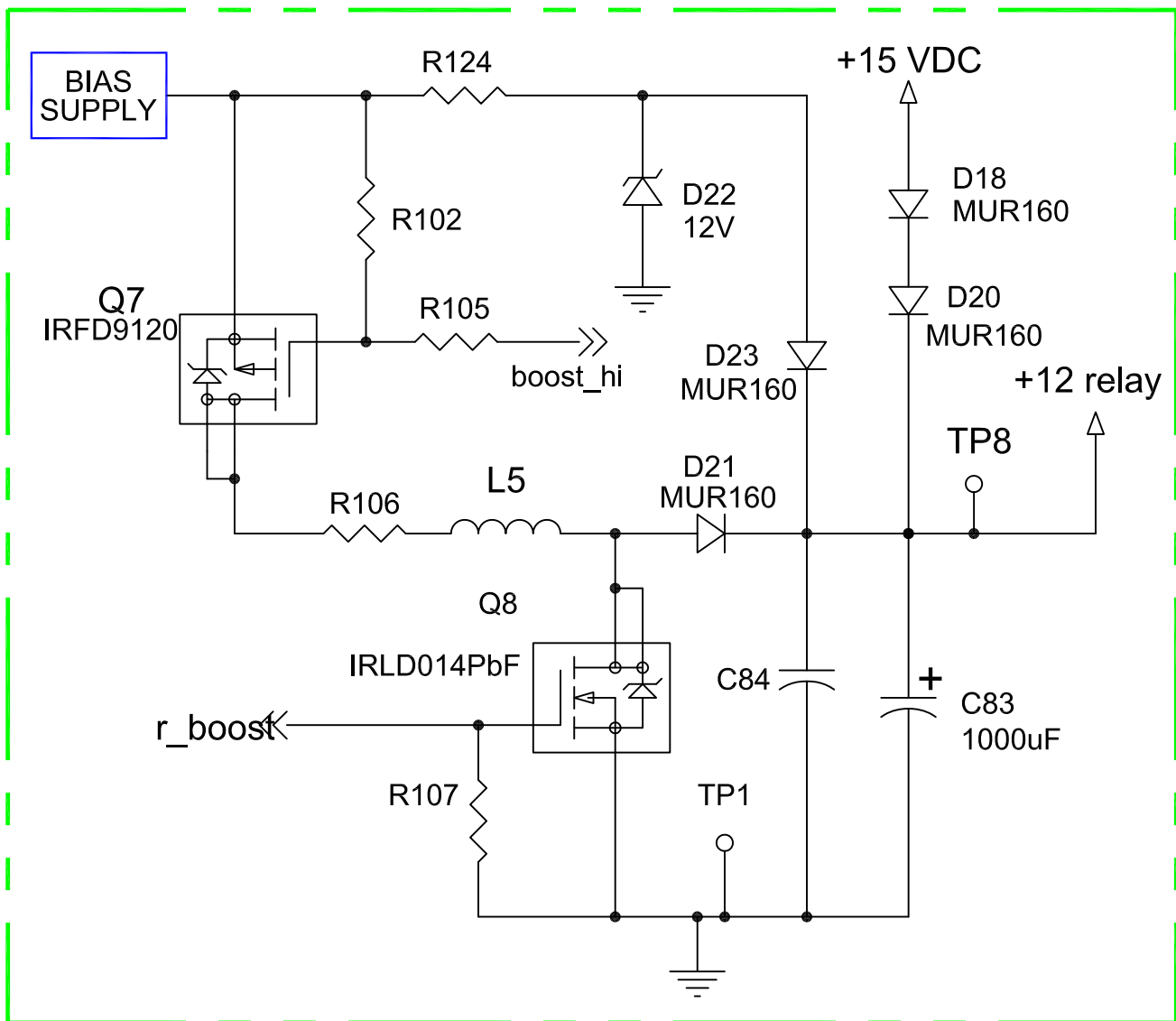

4.10.15 Power Board_PCB2 Torch Trigger Circuit (0558038315)

The Torch Trigger circuit consists of a 24 VAC signal that is rectified and passed to an opto isolator. The output of the opto isolator is then connected to the control board as the START signal.

24VAC is sent out on J12 pin 2 and routed to either the PT38 torch trigger or to a CNC. Once the torch switch is closed, the 24VAC is returned on J9 pin 2 and sent to D3, a full wave bridge. This rectifies the AC signal and sends DC power out to the opto-isolator U7 to fire it. Once the opto-isolator is fired, the output of U7 pin 5 is then sent to the control board via J4 pin 17.

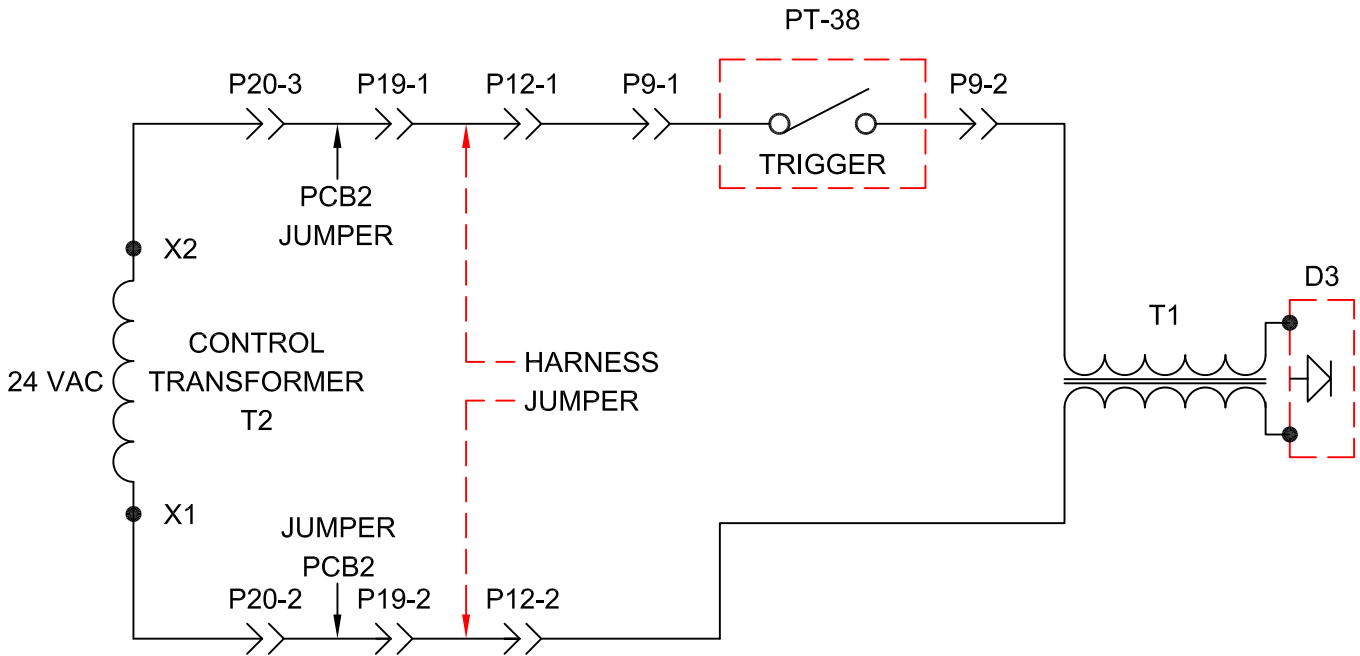
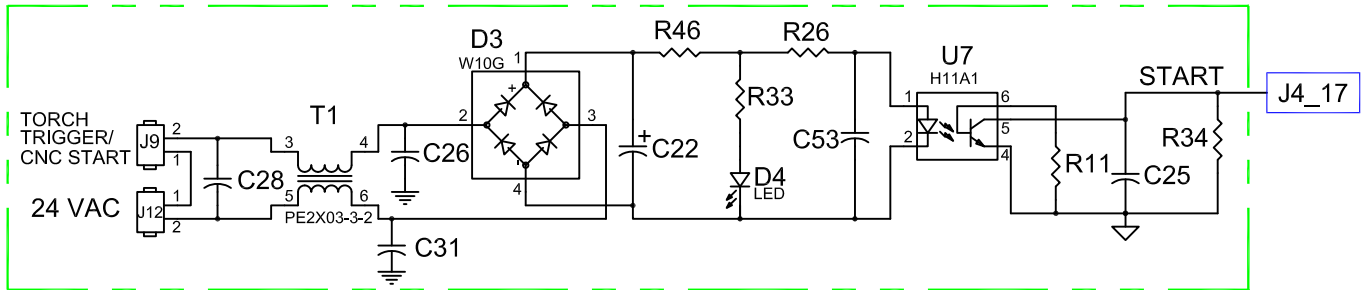

4.10.16 Buss Supply/IGBT

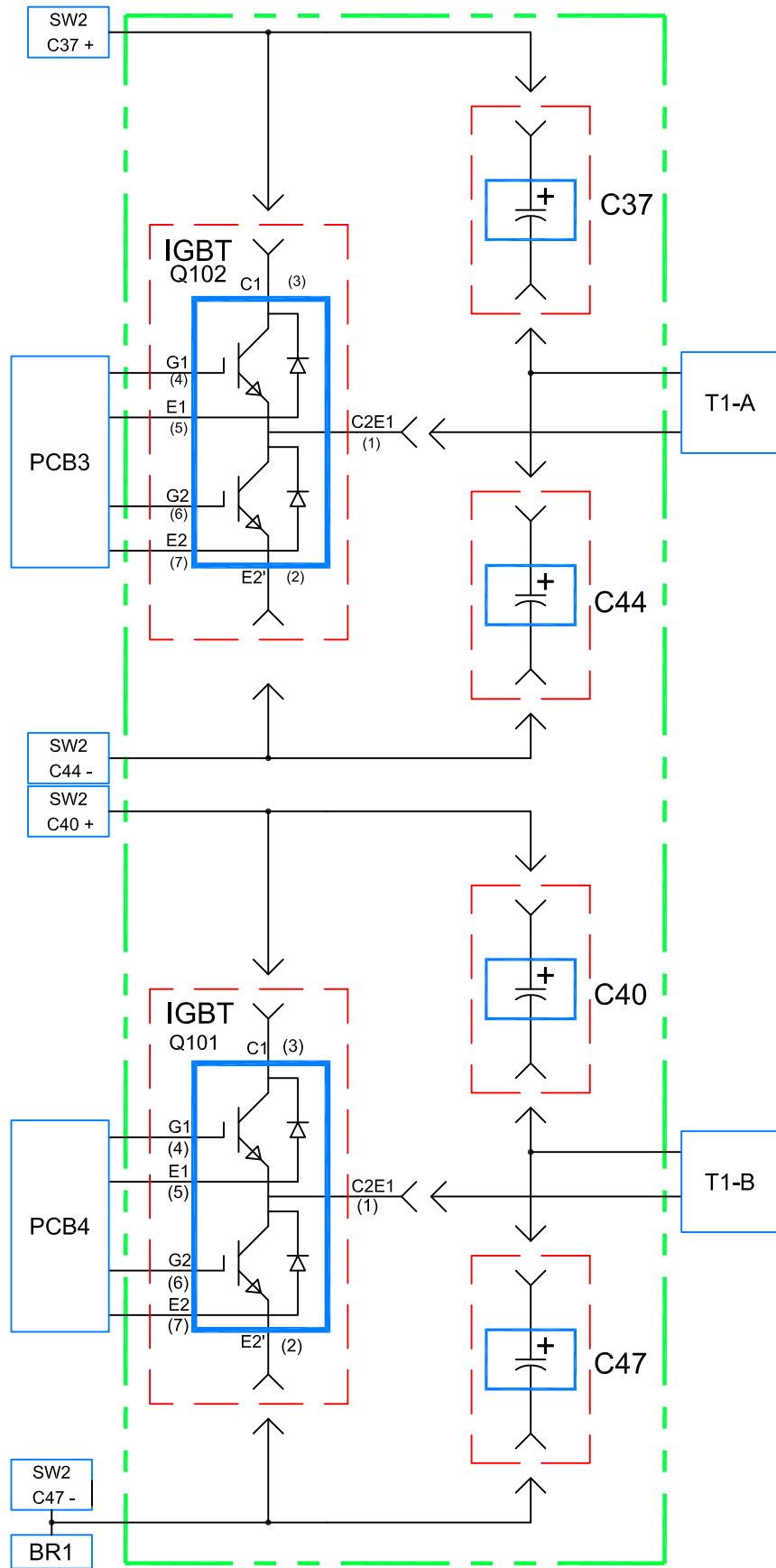

4.10.16 Power Board_PCB2 Filter Buss/IGBT Circuit (0558038315)

The Inverter blocks of the PC1600 is where the stored energy in the buss supply (DC power) is converted to AC and supplied on to the output bridge. Two half bridge inverters are used (allows 230/460 switching) and the output from them is combined at the secondary of the main transformers (T1-A and T1-B).

Components used: 2- twin IGBT transistors, Q101 and Q102
 4-Electrolytic Capacitors, C37, C40, C44 and C47
 2- Main transformers T1-A and T1-B

The Filter Buss capacitors receive power from either the pre-charge of the inrush circuit or from the main contactor K1. (See the inrush circuit for more detail) Once the bus is fully charged, each of the four filter caps will have a nominal voltage of 162 VDC across it's terminals. The filter caps then reduce the ripple on the rectified voltage and supply the filtered bus voltage to the IGBT circuits. Each IGBT circuit (or half-bridge) will have a nominal buss voltage of 325 VDC, whether configured for 230 VAC input or 460 VAC input.

Capacitor Information

CAUTION

Serious Shock Possible

The "buss capacitors" in the PC1600 will maintain a voltage charge for approximately 2 minutes after power is removed from the input of the machine.

The arcing caused by discharging a capacitor into a short-circuit can cause injury and component damage

To eliminate the voltage from the capacitor, connect the "bleeder resistor" across the poles of a charged capacitor and the stored energy will discharge harmlessly through the resistor. The approximate discharge time is 30 seconds.

When discharged, the cap can be partially tested by using a multimeter set to the ohms scale. When checking a good capacitor...Connect the + meter lead to the + pole of the capacitor, and the - lead to the - pole. The meter display will show a number that will change while the leads are connected, if the meter leads are reversed, the display will change polarity and the value will change in the opposite direction from the first test.

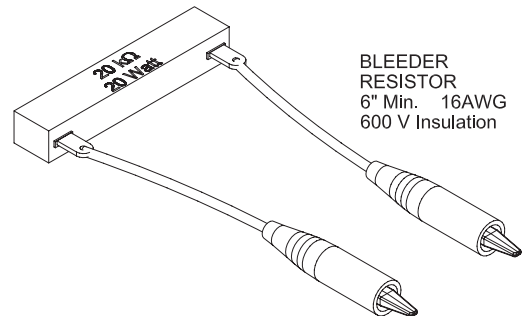

4.10.16 Buss Supply

Note: In the early models of the PC1600, the power board labeled the Buss supply capacitors with numbers that are different than the schematic.

Conversion Information:

Early model label	Current models
C37	C104
C40	C102
C44	C103
C47	C101

Buss Supply

The inverter block filter section, known as the Buss Supply, comprises C37, C40, C44, C47, R14 and R15. The purpose of this section is to transform the pulsating DC to a level DC operating voltage. The drawing below represents the output of the input bridge BR1.

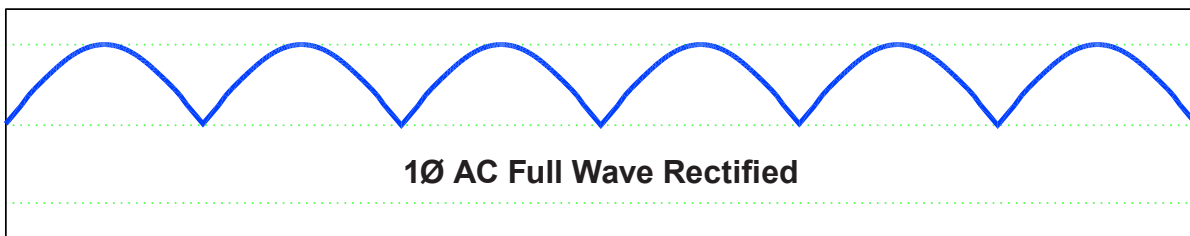
**Buss Supply**

The inverter block filter section, known as the Buss Supply, comprises C37, C40, C44, C47, R14 and R15. The purpose of this section is to transform the pulsating DC to a level DC operating voltage.

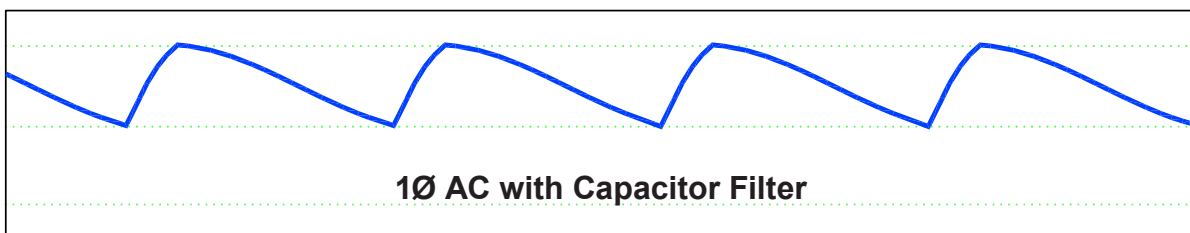

4.10.16 Filter Buss

The drawing below represents the output of the input bridge BR1. The bulk of the filtering is done when the capacitors C37,C40, C44, C47 charge. These large value capacitors act as a well, resisting changes in voltage with an ebb and flow effect, charging and discharging in contrast to the rise and fall of their input voltage. A graphical representation of this is shown in the drawing below.

The resistors R14 & R15, are in place to bleed off the residual voltage in the capacitors once the power supply is de-energized, and so they are referred to as “bleeder resistors”.

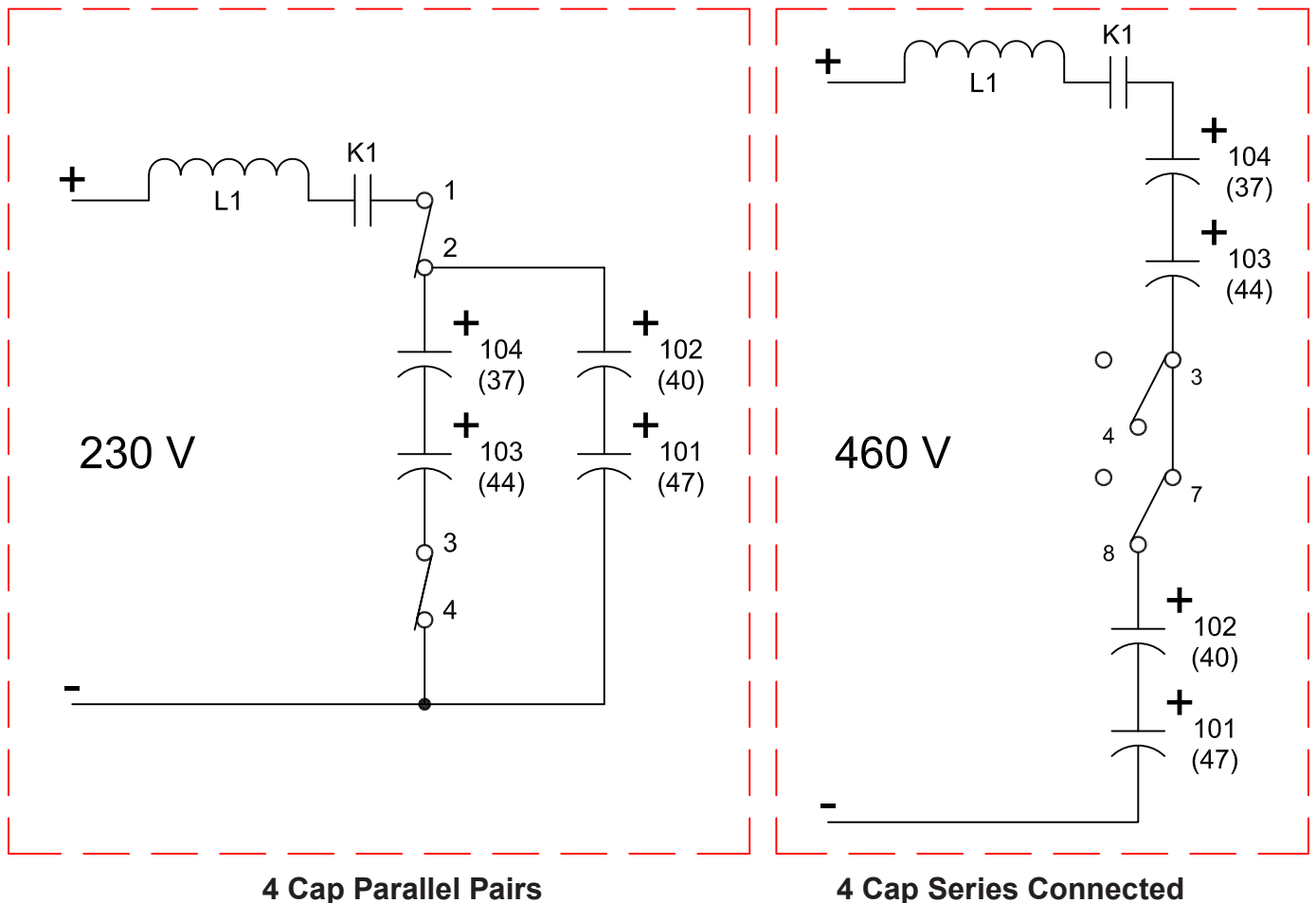
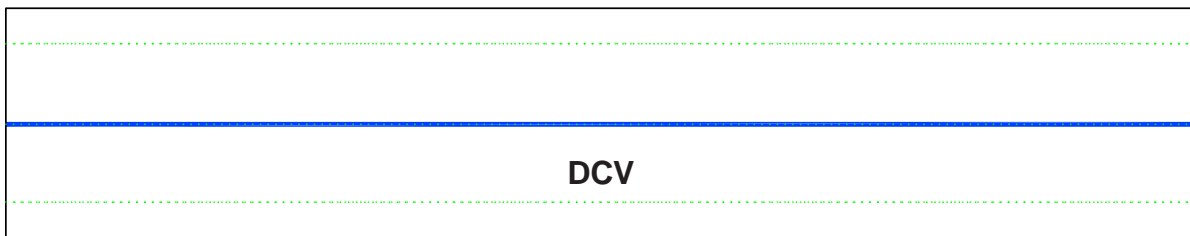

4.10.16 Power Board_PCB2 Filter Buss/IGBT (0558038315)

When the converter is on, the IGBT circuit delivers an 18.5 KHz AC power to the main transformers. The IGBTs are gated on by signals from the driver boards and regulate the output of the PC 1600 (see Section 4.10.21).

Some filter capacitors hold charges for long periods of time. Charged capacitors can present a shock hazard. It is not safe to assume the capacitors have been drained even if there is a bleeder resistor across them. Technicians who work with high voltage supplies use a shorting rod or a shorting stick to be certain that all the filters are drained before working on the equipment. High-energy capacitors can discharge violently, so it is important that the shorting rod contain a high-wattage resistor of around 20 ohms to keep the discharge current reasonable.

The filter caps are configured in two different ways in the PC1600 230/460 model, dependant upon the input voltage. The power selector switch S3 will place the four filter capacitors in either a series configuration or in a parallel pair configuration.

In the 460 VAC mode of operation, the four capacitors are placed in series – all four capacitors connected in a daisy chain, each capacitor dropping 162.5 VDC. (See Section 4.10.16 “Series connected”) In the 230 VAC mode of operation, the four capacitors are divided up into two pairs. Each pair has two capacitors in series and then the pairs are placed in parallel with one another. (See Section 4.10.16 “Parallel connected”) again each capacitor supplying 162.5 VDC.

In 400 VAC and 575 VAC units, the capacitors are in series. There is no power selector switch in the 400 VAC or the 575VAC units.

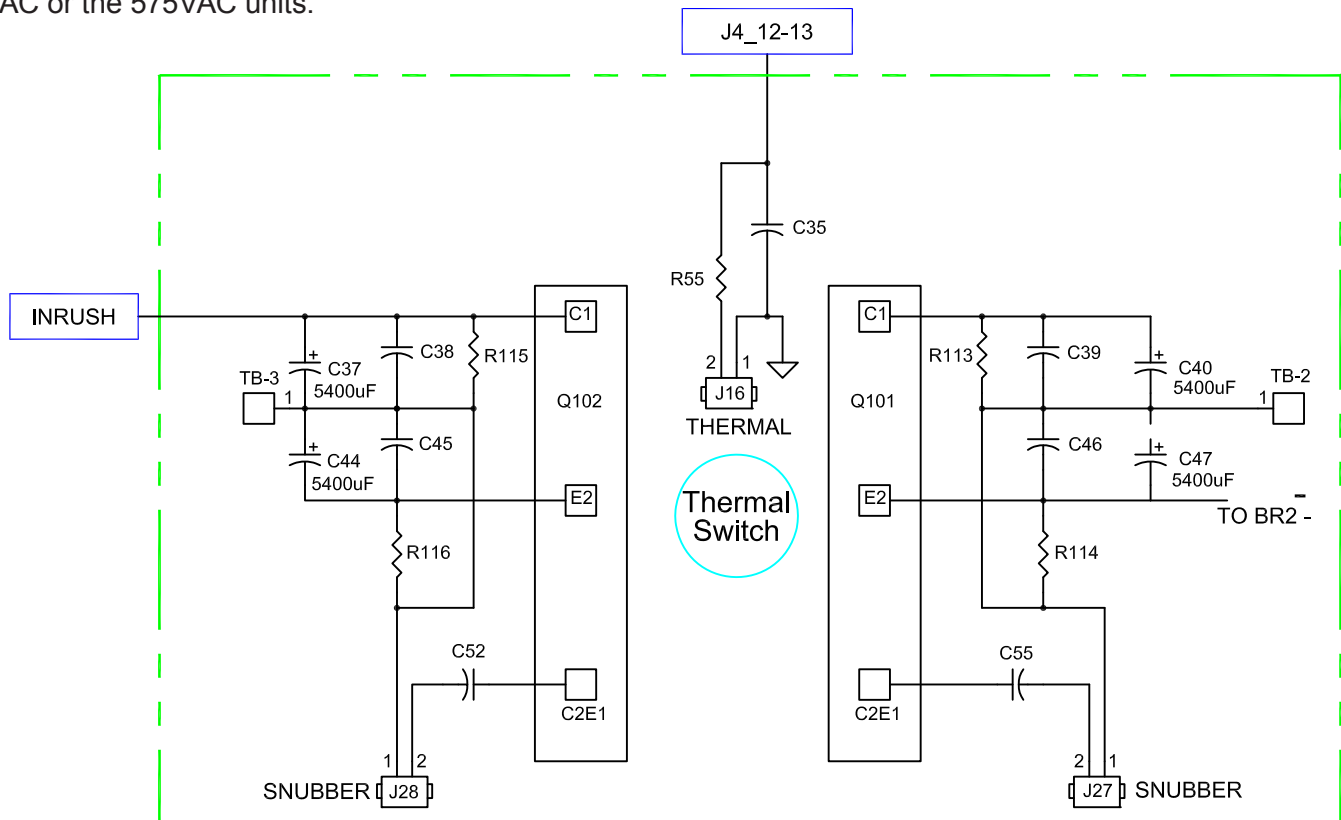

4.10.18 Power Board_PCB2 Thermal Switch Circuit (0558038315)

The Thermal switch circuit supplies +15 VDC out to the Thermal switch. This is then passed through the thermal switch and returned to the power board where the voltage is passed to ground. The output of this circuit is a logic low that is sent to the microcontroller on the Main Control Board PCB1. If the Thermal switch opens, this will place a logic high on the microcontroller input and set a thermal fault on the PC1600. The thermal interlock is "self-resetting" When the temperature of the monitored device cools to an acceptable operating temperature, the fault is reset and output will return.

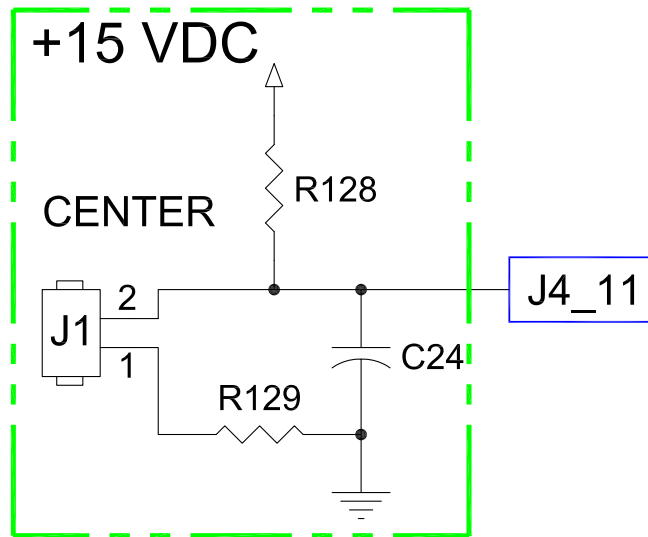

4.10.19 Power Board_PCB2 Gate Driver Circuit (0558038315)

The gate driver circuit accepts the gate pulses from the control board. Here the 19 KHz pulsed signals are buffered and then sent to the IGBT driver boards.

Gate pulses from the control board are input on J7 pins 1 and 3. These are routed to U1 and U3 respectively which buffers the signals and drives the power MOSFETs, Q1 and Q2, used to supply pulses to the Power Driver boards PCB3 and PCB4.

Testing: TP1 is board common

TP6 = 18.5 KHz pulses @14 VAC

TP7 = 18.5 KHz pulses @14 VAC

J25 pin 1 to pin 2 = 18.5 KHz pulses @33 VAC

J25 Pin 3 to pin 2 = 18.5 KHz pulses @33 VAC

J24 Pin 1 to pin 2 = 18.5 KHz pulses @33 VAC

J24 Pin 3 to pin 2 = 18.5 KHz pulses @33 VAC

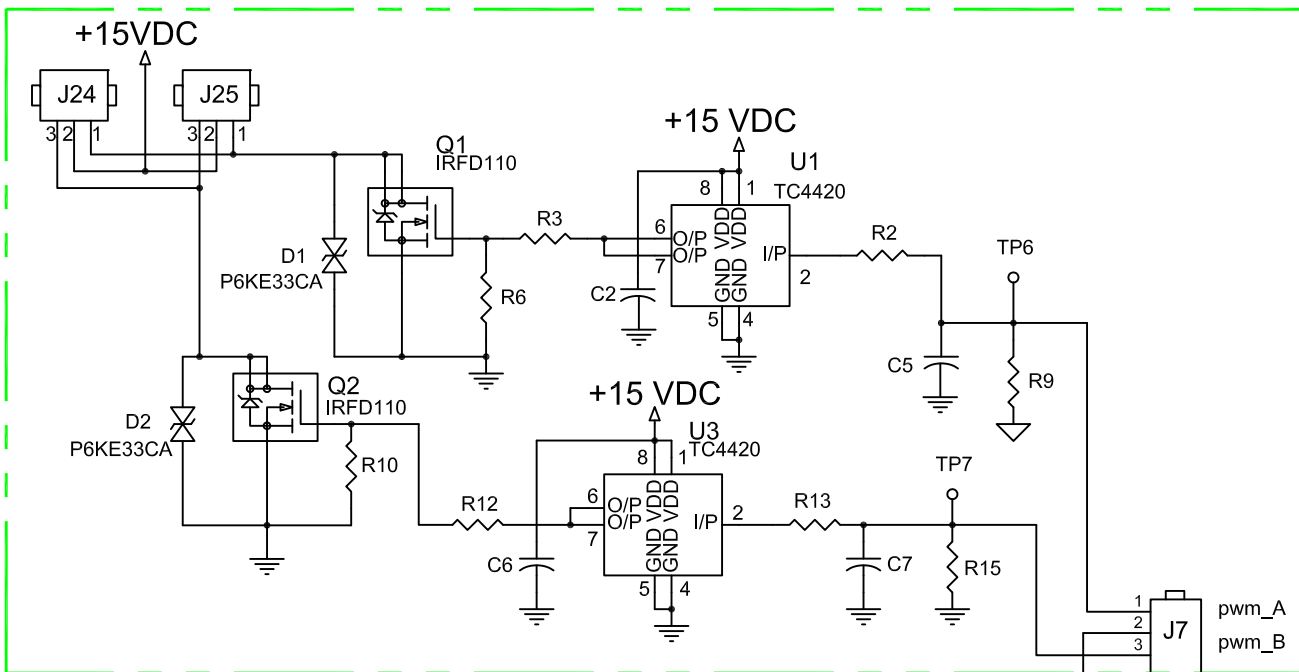

4.10.20 Power Board_PCB2 RS232 Interface (0558038315)

The control board has an RS232 interface built into it that connects to the control board through the J7 ribbon cable header (header J2 on the control card). This is used for communication between the power board controller and the main controller. This communication channel is also used for computer testing of the machine, accessed through the J5 connector on the power board

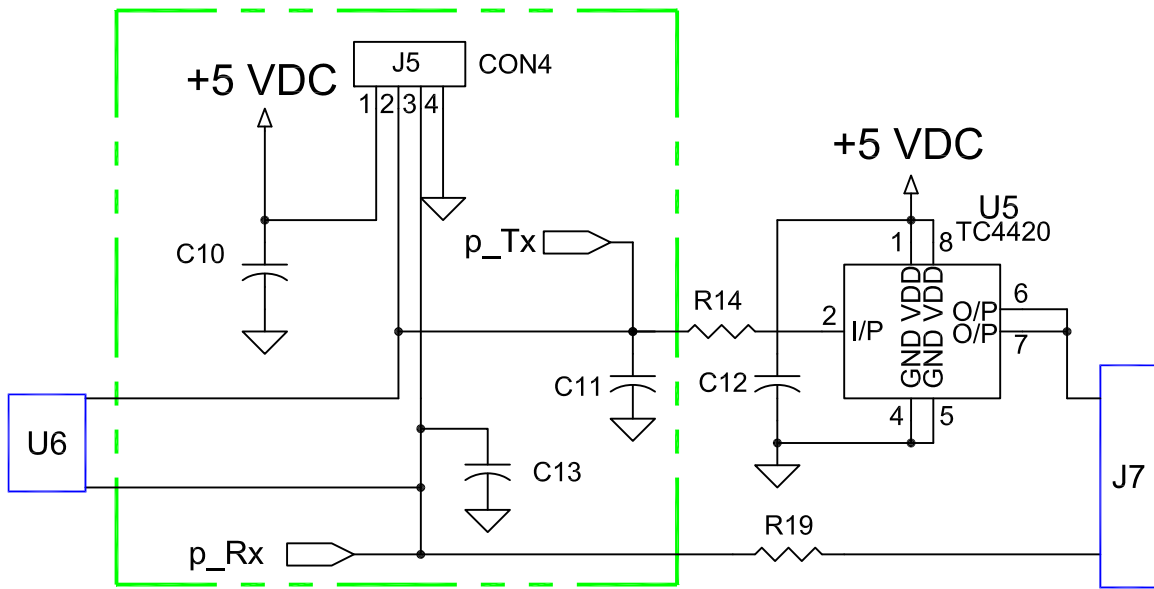

SECTION 4

DESCRIPTION OF OPERATION

4.10.21 Power Board_PCB2 Layout (0558038315)

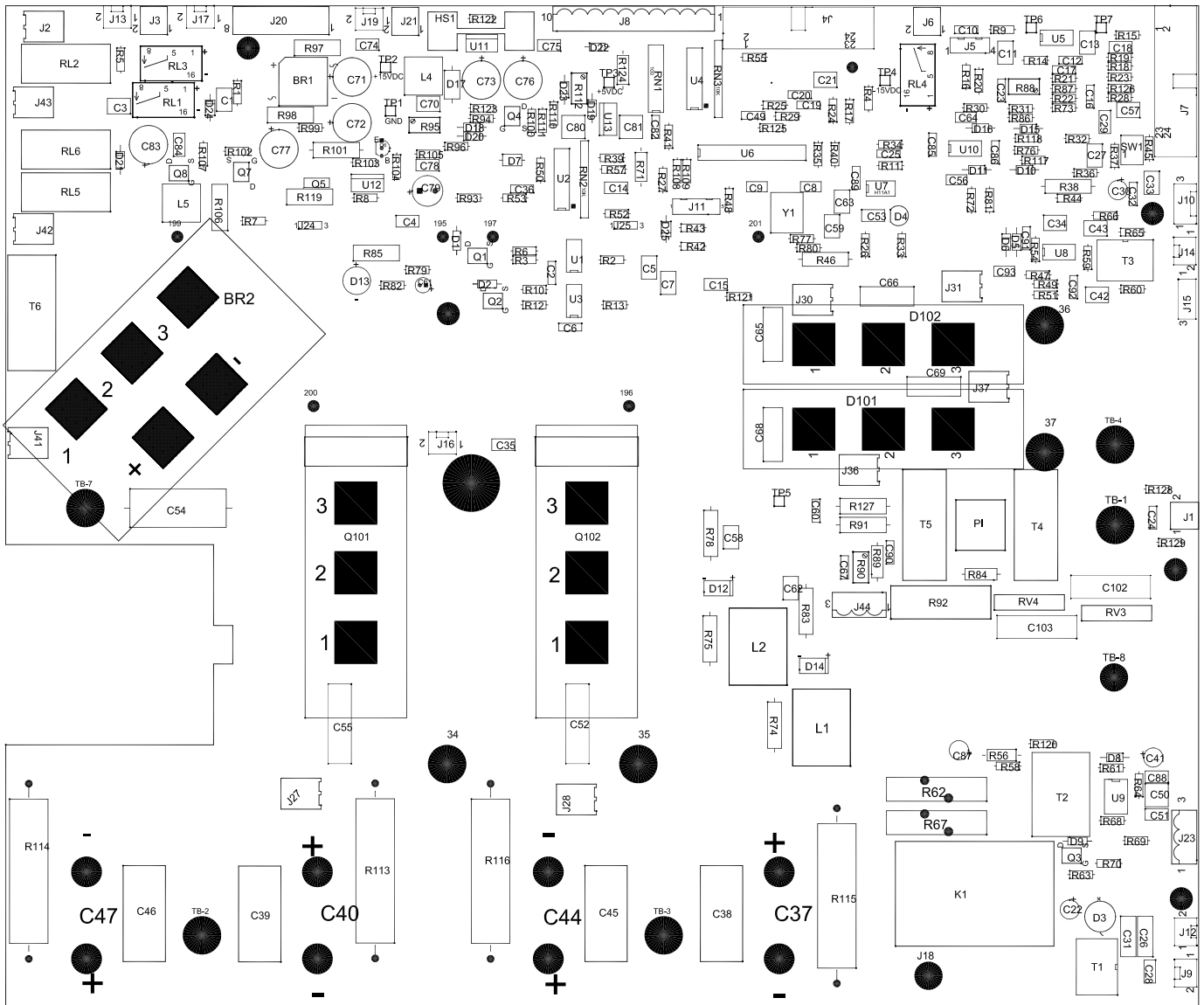

PCB2 POWERBOARD COMPONENTS			
ITEM	QTY	DESCRIPTION	SYMBOL
1	1	DRILLED BOARD	
2	1	BRIDGE, 3A, 400V, GBPC 104	BR1
3	14	CAP, 680pF, 100VDC, MET-POLY	C4,C3,C11,C13,C18,C21,C27,C33,C57,C58,C59,C62,C63,C70
4	16	CAP, 0.22uF, 100VDC, CERAMIC	C2,C6,C10,C12,C16,C23,C32,C36,C49,C60,C82,C85,C86,C90,C91,C92
5	11	CAP, 0.1uF, 100VDC, MET-POLY	C1,C28,C29,C35,C67,C74,C75,C78,C84,C88,C89
6	5	CAP, 330pF, 200VDC, CERAMIC	C5,C7,C34,C42,C43
7	2	CAP, 27pF, 300VDC, MICA	C8,C9

SECTION 4**DESCRIPTION OF OPERATION****4.10.21****Power Board_PCB2 BOM (0558038315)**

PCB2 POWERBOARD COMPONENTS			
ITEM	QTY	DESCRIPTION	SYMBOL
8	2	CAP, 0.001uF, 100VDC, MET-POLY	C14,C15
9	6	CAP, 0.01uF, 100VDC, MET-POLY	C17,C19,C20,C24,C25,C53
10	2	CAP, 22uF, 63VDC, ELECT.	C22,C61
11	3	CAP, 47uF, 35VDC, ELECT.	C30,C41,C87
12	2	CAP, 0.0047uF, 1000VDC, EMI	C26,C31
13	4	CAP, 2.2uF, 400VDC, MET-POLY	C38,C39,C45,C46
14	3	CAP, 4.7uF, 50VDC, MET-POLY	C50,C80,C81
15	1	CAP, 0.1uF, 100VDC, CERAMIC	C51
16	4	CAP, 0.022uF, 1000VDC, FILM	C52,C55,C102,C103
17	1	CAP, 0.22uF, 1000VDC, FILM	C54
18	3	CAP, 100pF, 50VDC, CER	C56,C64,C93
19	4	CAP, 0.01uF, 1000VDC, FILM	C65,C66,C68,C69
20	6	CAP, 1000uF, 35VDC, ELECT.	C71,C72,C73,C76,C77,C83
21	1	CAP, 100uF, 63VDC, ELECT.	C79
22	4	DIODE, P6KE33CA	D1,D2,D7,D9
23	2	DIODE, BRIDGE, W10G	D3,D13
24	1	DIODE, LED, RED	D4
25	12	DIODE, MUR160	D5,D6,D8,D10,D11,D15,D16,D18,D19,D20, D21,D23
26	2	DIODE, BRIDGE, EDF1DM	D12,D14
27	1	DIODE, MUR 460	D17
28	1	DIODE, ZENER, 1N4742A	D22
29	2	DIODE, SCHOTTKY, 11DQ05	D24,D25
30	2	HEADER, 3 PIN	J24,J25
31	10	HEADER, HORIZ, 2 PIN, AMP 1437671-1	J2,J27,J28,J30,J31,J36,J37,J41,J42, J43
32	4	HEADER, HORIZ, PHOENIX, 2 PIN	J1,J3,J6,J21
33	2	HEADER, HORIZ, RIBBON, 24 PIN	J4,J7
34	1	HEADER, VERT, AMP, 4 PIN	J5
35	1	HEADER, VERT, PHOENIX, 10 PIN	J8
36	7	HEADER, VERT, AMP, 2 PIN	J9,J12,J13,J14,J16,J17,J19
37	1	HEADER, VERT, AMP, 3 PIN	J10
38	1	HEADER, VERT, AMP, 5 PIN	J11
39	1	HEADER, VERT, AMP, 3 PIN	J15
40	2	INSERT	J18,TB-8
41	1	HEADER, HORIZ, PHOENIX, 8 PIN	J20
42	2	HEADER, VERT, PHOENIX, 3 PIN	J23,J44

SECTION 4

DESCRIPTION OF OPERATION

4.10.21

Power Board_PCB2 BOM (0558038315)

PCB2 POWERBOARD COMPONENTS			
ITEM	QTY	DESCRIPTION	SYMBOL
43	1	RELAY, POTTER BRUMFIELD T92	K1
44	2	TRANSFORMER, CURRENT, CC040616	L1,L2
45	2	INDUCTOR, 115uH, PE53820	L4,L5
46	1	CONN. POWER, AMP	P1
47	3	TRANSISTOR, FET, IRFD110	Q1,Q2,Q4
48	2	TRANSISTOR, FET, IRLD014PbF	Q3,Q8
49	1	TRANSISTOR, NPN, SILICON, MJE243	Q5
50	1	TRANSISTOR, PNP, SILICON, BC640	Q6
51	1	TRANSISTOR, FET, IRFD9120	Q7
52	3	RELAY, SPST, 12VDC	RL1,RL3,RL4
53	1	RELAY, SPST, 12VDC	RL2
54	1	RELAY, DPDT, 12VDC, G2R-24-DC12	RL5
55	1	RELAY, DPST, 12VDC, G2R-2A4-DC12	RL6
56	1	RES, NET, 16 PIN DIP, 100 OHM	RN1
57	2	RES, NET, 10 PIN SIP, 10K	RN2,RN3
58	2	VARISTER, 369VDC	RV3,RV4
59	19	RES, 1K, 0.25W, 1%	R1,R5,R7,R8,R18,R25,R27,R28,R29R32,R35, R45,R49,R66,R77,R80,R93R111,R125
60	19	RES, 100, 0.25W, 1%	R2,R3,R12,R13,R14,R19,R24,R39,R55,R57, R60,R63,R65,R69,R73,R117,R118, R121,R129
61	8	RES, 499, 0.25W, 1%	R4,R20,R22,R26,R30,R52,R72,R81
62	12	RES, 4.99K, 0.25W, 1%	R6,R9,R10,R15,R16,R40,R44,R59,R70,R100, R102,R107
63	1	RES, 100K, 0.25W, 1%	R11
64	2	RES, 237, 0.25W, 1%	R17,R110
65	16	RES, 10K, 0.25W, 1%	R23,R31,R34,R37,R41,R42,R43,R47,R48, R50,R51,R54,R68,R104,R126,R128
66	2	RES, 1.5K, 0.25W, 1%	R33,R94
67	9	RES, 2K, 0.25W, 1%	R21,R36,R61,R76,R86,R99,R103,R105,R120
68	4	RES, 2.7, 3W, 1%	R38,R74,R75,R85
69	1	RES, 1K, 1W, 10%	R46
70	1	RES, 3.32K, 0.25W, 1%	R53
71	2	RES, 2K, 0.5W, 1%	R56,R124
72	2	RES, 10, 0.25W, 1%	R58,R64
73	2	RES, 20, INRUSH	R62,R67

SECTION 4**DESCRIPTION OF OPERATION****4.10.21****Power Board_PCB2 BOM (0558038315)**

PCB2 POWERBOARD COMPONENTS			
ITEM	QTY	DESCRIPTION	SYMBOL
74	1	RES, 20, 0.5W, 1%	R71
75	2	RES, 5.0, 3W, 5%	R78,R83
76	2	RES, 20K, 0.25W, 1%	R79,R96
77	1	RES, 49.9, 0.25W, 1%	R82
78	1	RES, 121, 0.5W, 1%	R84
79	1	RES, 453, 0.25W, 1%	R87
80	3	RES, TRIMPOT, 500	R88,R95,R112
81	1	RES, 150, 0.5W, 1%	R89
82	1	RES, TRIMPOT, 1K	R90
83	3	RES, 2K, 3W, 5%	R91,R101,R127
84	1	RES, 15K, 8W, 5%	R92
85	2	RES, 0.1, 3W, 5%	R97,R98
86	2	RES, 1, 3W, 5%	R106,R119
87	2	RES, 0, 0.25W, 1%	R108,R109
88	4	RES, 8K, 15W, 5%	R113,R114,R115,R116
89	2	RES, 49.9K, 0.25W, 1%	R122,R123
90	1	SWITCH, DIP 2 POSITION	SW1
91	5	INSERT	TB-1,TB-2,TB-3,TB-4,TB-7
92	7	TEST POINT	TP1,TP2,TP3,TP4,TP5,TP6,TP7
93	2	TRANSFMR, COMMON MODE, FE2X03-3-2	T1,T3
94	1	TRANSFMR, 1:1, PE-63385	T2
95	2	HALL EFFECT, LEM 100-P	T4,T5
96	1	TRANSFMR, CURRENT, 60A, 50/60Hz	T6
97	3	I.C. DRIVER, MIC4420	U1,U3,U5
98	2	I.C. DISPLAY DRIVER, MC1413	U2,U4
99	1	I.C. MICRO-PROCESSOR, PIC 18F2320	U6
100	1	I.C. TRANSISTOR OPTO, H11A1	U7
101	2	I.C. DUAL OP-AMP, TL082CN	U8,U10
102	1	I.C. OPTO-ISOLATOR, HCNW3120	U9
103	1	REGULATOR, SWITCHING, LM2595-ADJ	U11
104	1	REGULATOR, -15VDC, MC7915AC	U12
105	1	REGULATOR, +5VDC, LM317T	U13
106	1	CRYSTAL, 8MHz	Y1
107	1	HEAT SINK / U13	
108	1	HEAT SINK / U12	

4.11 Power Driver _ PCB3 / PCB4 (0558038335)

The Power Driver circuit is used to drive the IGBTs to produce a current output from the PC1600. The power driver boards drive one half of each IGBT per half cycle. The two input transformers on the board are wired 180 degrees out of phase with each other so that the IGBTs may conduct for a full 360 degrees of pulsed output. Each transformer drives one of the two transistors on the IGBT for 180 degrees of pulse conduction.. During the negative half of the cycle, each driver circuit drives the gate of the IGBT negative, forcing the IGBT off.

During the positive half of the cycle, the pulse travels unaltered to the IGBT gate along the path of the solid line. It passes a pair of diodes, D1 and D2, a one amp fuse F1 and a surge diode D3. This is then sent to the gate of the IGBT and the transistor conducts. The negative half of the cycle follows a different path. The negative portion of the pulse conducts through Q1, Q2 and Q3, pulling the gate of the IGBT negative and forcing the transistor off.

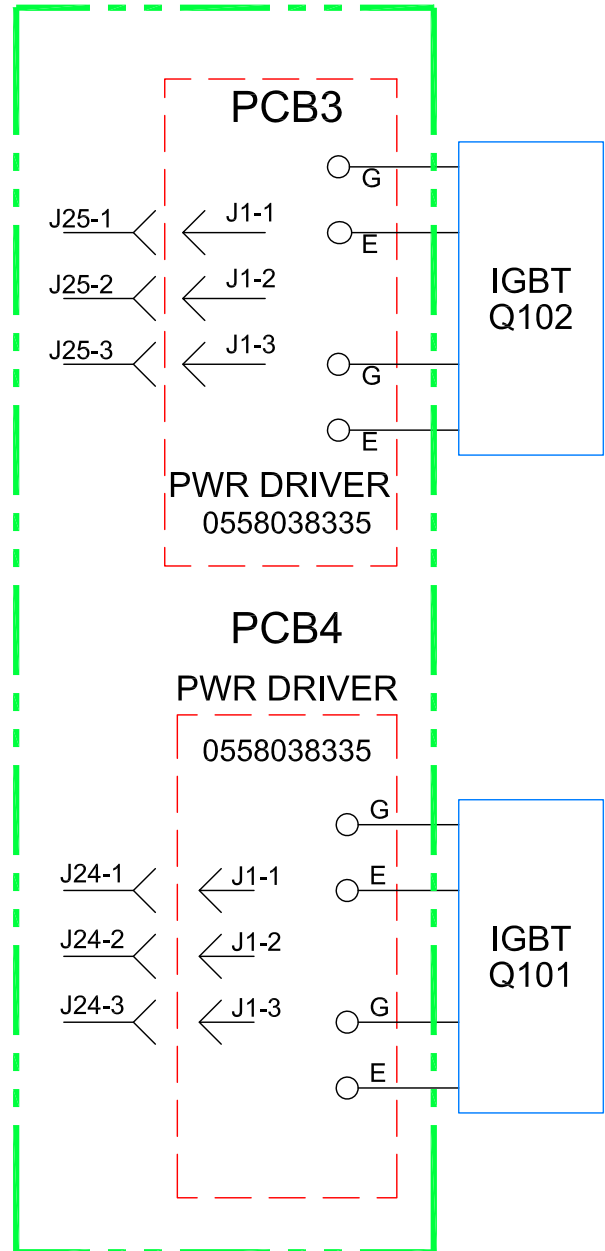

SECTION 4

DESCRIPTION OF OPERATION

4.11 Power Driver (0558038335)

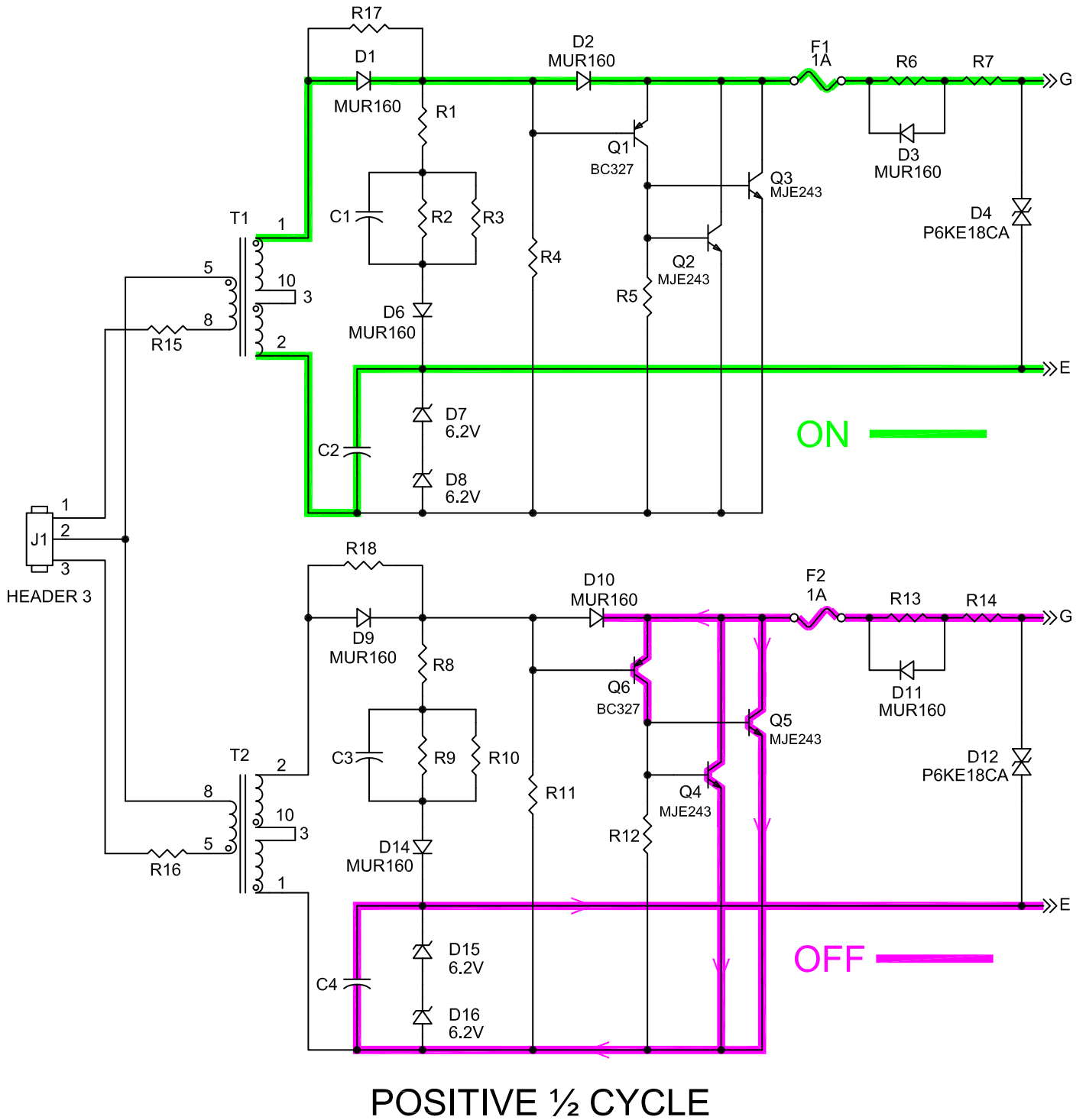

SECTION 4

DESCRIPTION OF OPERATION

4.11 Power Driver _ PCB3 / PCB4 (0558038335)

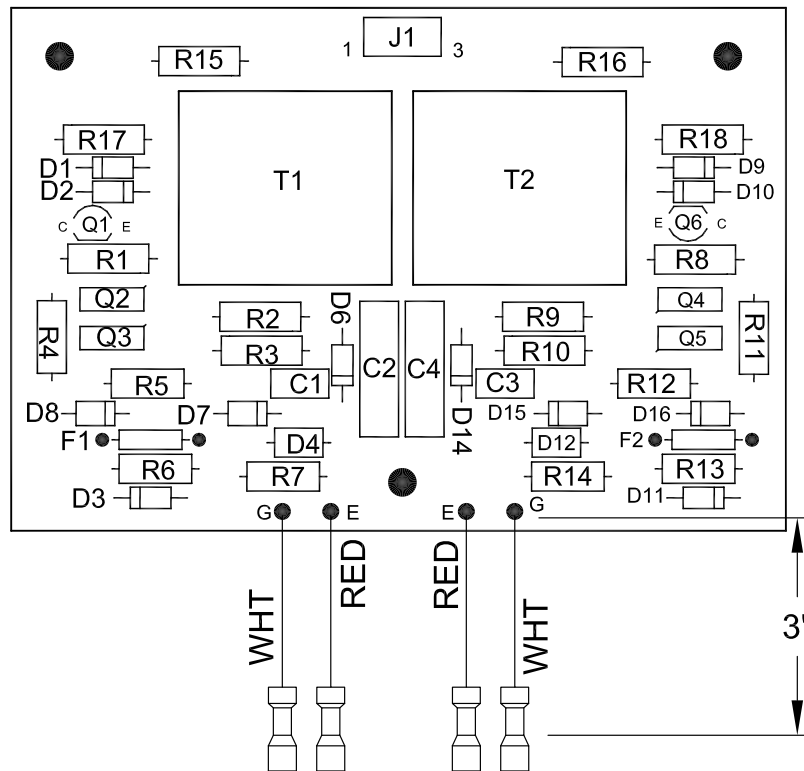

0558038335 DRIVER COMPONENTS			
ITEM	QTY	DESCRIPTION	SYMBOL
1	1	DRILLED BOARD	PCB
2	2	CAP, 0.22uF	C1,C3
3	2	CAP, 1uF	C2,C4
4	8	DIODE, SILICON, 1A, 600V, MUR160	D1,D2,D3,D6,D9,D10, D11,D14
5	2	DIODE, BI-DIRECTIONAL, P6KE18CA	D4,D12
6	4	DIODE, ZENER, 6.2V, 1W, 1N4735A	D7,D8,D15,D16
7	2	FUSE, 1A, 125V	F1,F2
8	1	HEADER SOCKET, 3 POS, BOTTOM FEED	J1
9	2	TRANSISTOR, PNP, SILICON, BC327	Q1,Q6
10	4	TRANSISTOR, NPN, SILICON, MJE243	Q2,Q3,Q4,Q5
11	2	RES, 27, 0.5W, 1%	R1,R8
12	4	RES, 470, 1W, 1%	R2,R3,R9,R10
13	4	RES, 470, 0.5W, 1%	R4,R5,R11,R12
14	4	RES, 4.7, 0.5W, 1%	R6,R7,R13,R14
15	2	RES, 0.5, 0.5W, 1%	R15,R16
16	2	RES, 20K, 0.5W, 1%	R17,R18
17	2	TRANSFORMER, VAC T60403-D4185-X032	T1,T2
18	6"	WIRE, 600V RED 20 AWG 19/32 STRAND	E
19	6"	WIRE, 600V WHT 20 AWG 19/32 STRAND	G
20	4	TERMINAL, FASTON 0.110 INSULATED	E&G WIRES

4.12 Thermal Switch TS1 (951085)

The thermal switch mounted on the heat sink between the IGBTs is a normally closed bimetallic switch that will open if the temperature of the output inductor exceeds 176° F. The switch will remain open until the inductor cools to 156° F. The switch is physically attached to the heat sink and connected to the power board at J1. This switch is electrically connected to the Main Control Board Microcontroller through the PCB2 J4/PCB1 J1 ribbon cable. When TS1 opens, it drives error code 4, shutting down the IGBTs until the unit cools. TS1 will “self reset” at 156° F allowing normal operation of the PC1600.

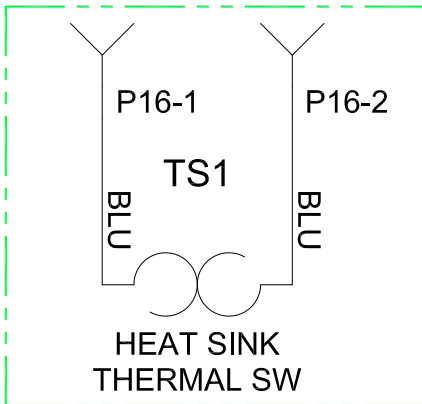
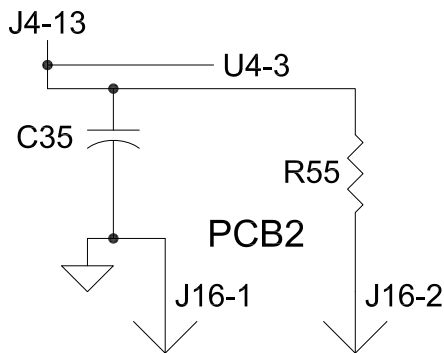

DESCRIPTION:

NORMALLY CLOSED THERMAL SWITCH
 OPEN TEMP. 176 ±5° F
 CLOSE TEMP. 156 ±5° F
 CONTACT RATINGS: 15 AMP MIN @12OVAC
 8 AMP MIN @ 24OVAC
 EPOXY SEAL ON THE DISC CUP AND TERMINALS
 U.L. RECOGNIZED
 CSA CERTIFIED PRODUCT

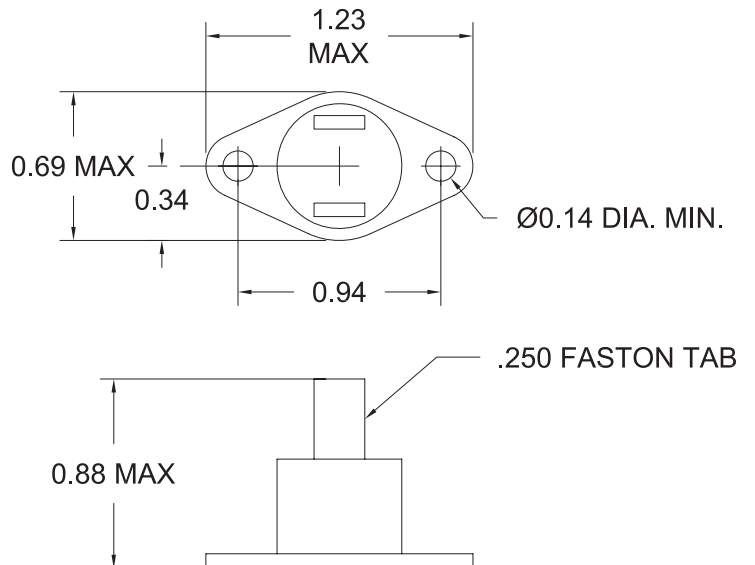

4.12 Thermal Switch TS2 (055807892)

The thermal switch mounted on the output inductor is a normally closed bimetallic switch that will open if the temperature of the Output inductor exceeds 176° F. The switch will remain open until the inductor cools to 156° F.

The switch is physically attached to the heat sink and connected to the power board at J16. This switch is electrically connected to the Main Control Board Microcontroller through the PCB2 J4/PCB1 J1 ribbon cable.

Testing: In circuit, measure tab 1 to tab 2 = less than 1 ohm

Note: When replacing TS2 a thin, uniform coating of heat sink compound must be applied to the mounting surfaces.

DESCRIPTION

NORMALLY CLOSED THERMAL SWITCH

OPEN TEMP. 176° ±5°F

CLOSE TEMP. 156° ±5°F

CONTACT RATINGS: 15 AMP MIN @120VAC

8 AMP MIN @ 240VAC

EPOXY SEAL ON THE DISC CUP AND TERMINALS

U.L. RECOGNIZED

CSA CERTIFIED PRODUCT

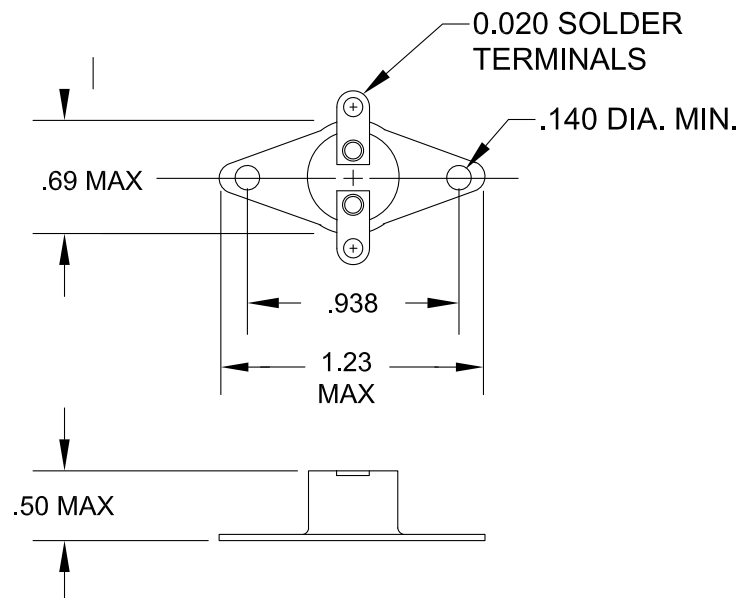

4.13 Pilot Arc Driver Board PCB5 (05580038344)

Pilot Arc IGBT Driver Circuit

The Pilot Arc IGBT is gated on when power is needed for pilot arc. The Main Power board PCB2 supplies a signal from J23 pin 1 and 3 to the IGBT driver board (PCB5). A 12 VAC signal is received in on PCB5 pins 1 and 2, conditioned, filtered and then passed on to the gate connection of Q103 (pilot arc IGBT).

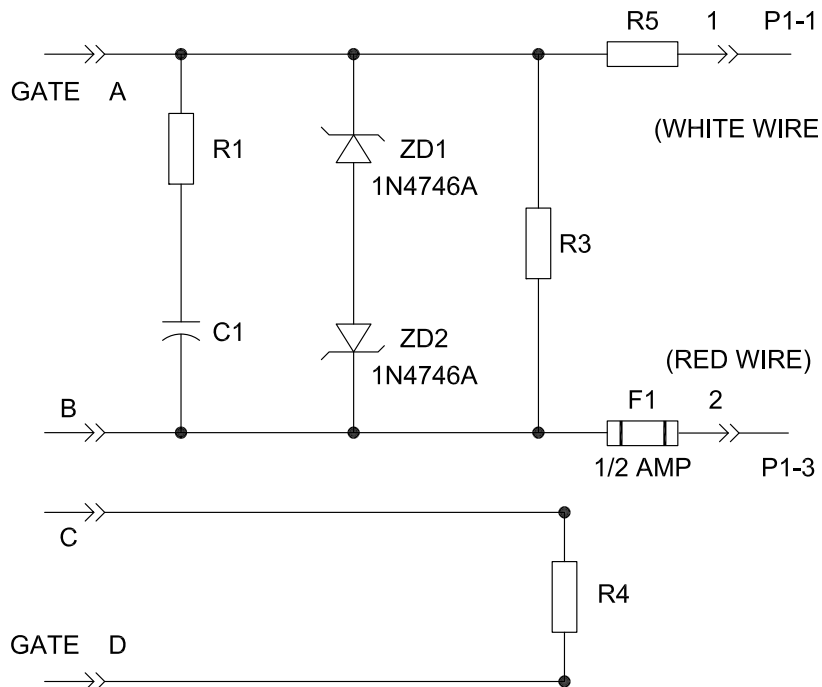
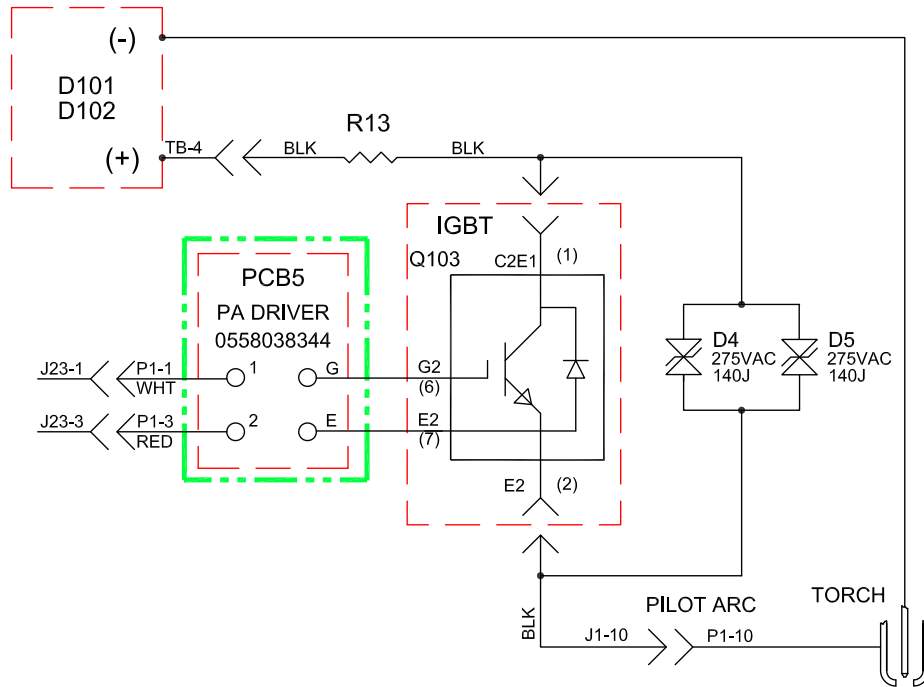

SECTION 4

DESCRIPTION OF OPERATION

4.13 Pilot Arc Driver _ PCB5 (0558038344)

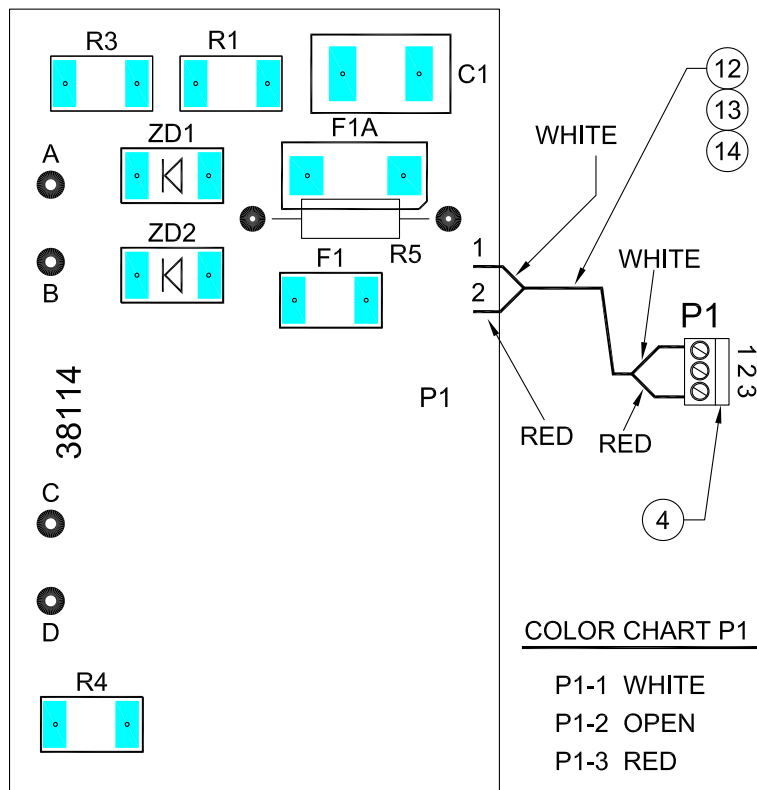

PCB5 (0558038344) Components			
ITEM	SYMBOL	QTY	DESCRIPTION
1		1	PCB DRILLED, IGBT DRIVER
2	C1	1	CAPACITOR, .047UF @ 63V
3	F1	1	FUSE, 1/2 AMP
4	P1	1	PLUG COMBICON 3 POS VERTICAL
5	R1	1	RESISTOR, 47.5 OHM 1/2W 1%
6	R3	1	RESISTOR, 1K 1/2W 1%
7	R4,R5	2	RESISTOR, 2.74 OHMS 1/2W 1%
8	ZD1-ZD2	2	DIODE, ZENER 18V, 2W 5% (1N4746A)
9		AR	EPOXY GEL FIVE MINUTE
10		4	TERMINAL, FASTON .110TSX22-18GA
11		AR	CONFORMAL COATING
12		AR	WIRE, 600V, #20AWG, 19 STRAND, RED
13		AR	WIRE, 600V, #20AWG, 19 STRAND, WHITE
14		17.00"	HEAT SHRINK, 3/16" CLEAR FOR CABLE

SECTION 4

DESCRIPTION OF OPERATION

4.14 Help Codes

Code	Error	Cause	Solution
1	Line voltage, idle +/- 15 %	Supply line voltage either dropped or exceeded nominal input setting.	Check voltage supply.
2	Line voltage, cutting +/- 20 %	Supply line voltage either dropped or exceeded nominal input setting during a cut.	Check voltage supply.
3	Control bias, +/- 15 V bias split	Control transformer not supplying the proper voltage to the control circuit	Check transformer and control board. Send unit to an Authorized Repair Station(ARS) for repair.
4	Thermal switch	Switch open - unit overheated.	Allow unit to cool down, check for adequate ventilation.
5	Pressure	Air pressure is outside of proper range.	Check air supply and pressure setting.
6	Fail to fire	Arc did not transfer. Arc will repeatedly "pop" out 3 consecutive times.	Check/replace consumables.
7	Pilot Arc time out (~5 seconds)	Pilot arc exceeded 5 second limit .	Transfer within 5 second limit. Check ground cable.
8	Torch error	Electrode in contact with nozzle (failed to separate).	Check/replace consumables. If problem persists replace/repair torch.
9			
10	Feedback improper	Primarily seen if current sensor is unplugged.	Check cable and connection between current sensor board and control board. Send unit to an ARS for repair.
11	Primary over-current	Converter failure.	Send unit to an ARS for repair.
12	Single phase operation, shutdown	Exceeded single phase duty cycle rating.	Operate within proper duty cycle rating.
13	OCV (open circuit voltage) failure	Voltage or current not detected when test (PIP) is performed.	Send unit to an Authorized Repair Station for repair.
14	Cabinet temperature	Too high, outside of operating limits.	Check ventilation around unit. Check air louvers and any other openings to ensure that any obstruction is removed.
15	Bus charger failure	Primary bus not up to voltage.	Check bus charger. Send unit to an ARS for repair. Effective Prog.Ver 1.03. Error 15 will reset with "power off/on
16	Not Available		
17	Not Available		
18	Not Available		
19	Not Available		
20	PIP (Parts in place) no retract	Piston did not retract when air applied.	Check/clean consumables. Check air supply.
21	PIP (Parts in place) no continuity	Piston did not drop back in place when air was removed.	Check/clean consumables. Ensure proper installation of consumables.

4.15 Pressure Transducer (0558006148)

The Pressure Transducer is a 4 – 100 PSI unit designed to output 0 to 4.5 VDC to the control board as feedback for the pressure output to the torch.

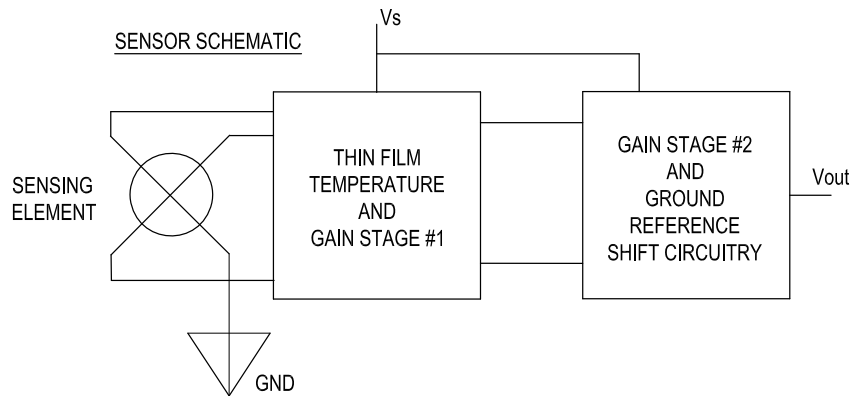
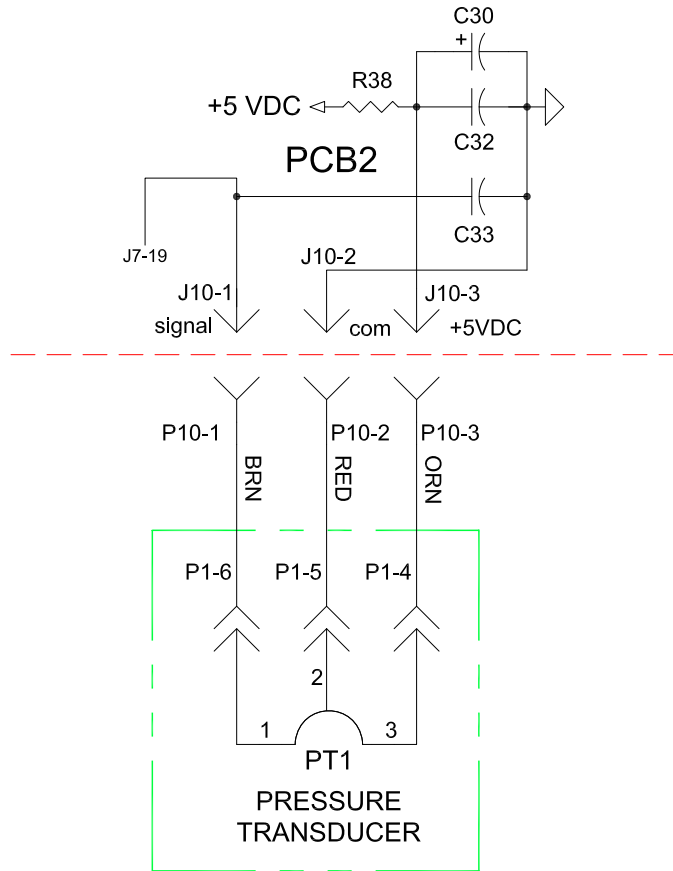

SECTION 4

DESCRIPTION OF OPERATION

4.15 Pressure Transducer (0558006148)

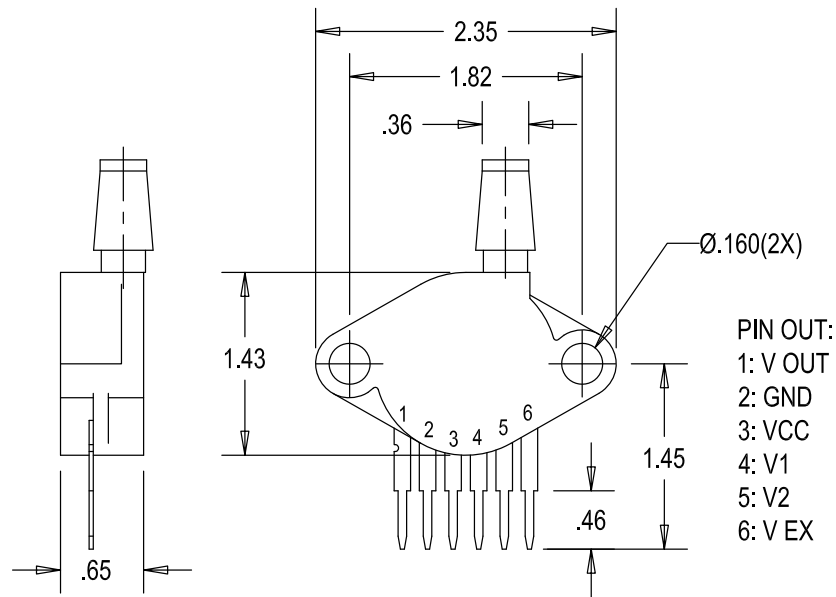

PARAMETRICS	SYMBOL	VALUE	UNIT
MAX PRESSURE (P2<1 ATMOSPHERE)	P1max	2800	kPa
STORAGE TEMP.	Tstg	-40 to 125	°C
OPERATION TEMP.	Ta	-40 to 125	°C

CHARACTERISTICS	SYMBOL	MIN	TYP	MAX	UNIT
PRESSURE RANGE (1kPa=0.145psi)	Pop	15		700	kPa
SUPPLY VOLTAGE	Vs	4.75	5	5.25	Vdc
SUPPLY CURRENT	Io		7	10	mAdc
ZERO PRESSURE OFFSET	Voff	0.184		0.409	Vdc
FULL SCALE OUTPUT	Vfso	4.587	4.7	4.813	Vdc
FULL SCALE SPAN	Vfss		4.5		Vdc
ACCURACY				± 2.5	%Vfss
SENSITIVITY	V/P		6.4		mV/kPa
RESPONSE TIME	tR		1		ms
OUTPUT SOURCE CURRENT @ FULL SCALE OUTPUT	Io+		0.1		mAdc
WARM-UP TIME			20		ms

4.16 EMC Filter 50A _ PCB7 (CE Units _ 0455803880)

The EMC Filter board is used on the 575VAC/460VAC and 400 VAC CE units to further reduce the electro-magnetic interference of the unit.

NOTE: This component is rated for handle 3 phase currents (50 amps Max).Single phase usage will cause failure to the EMC filter.

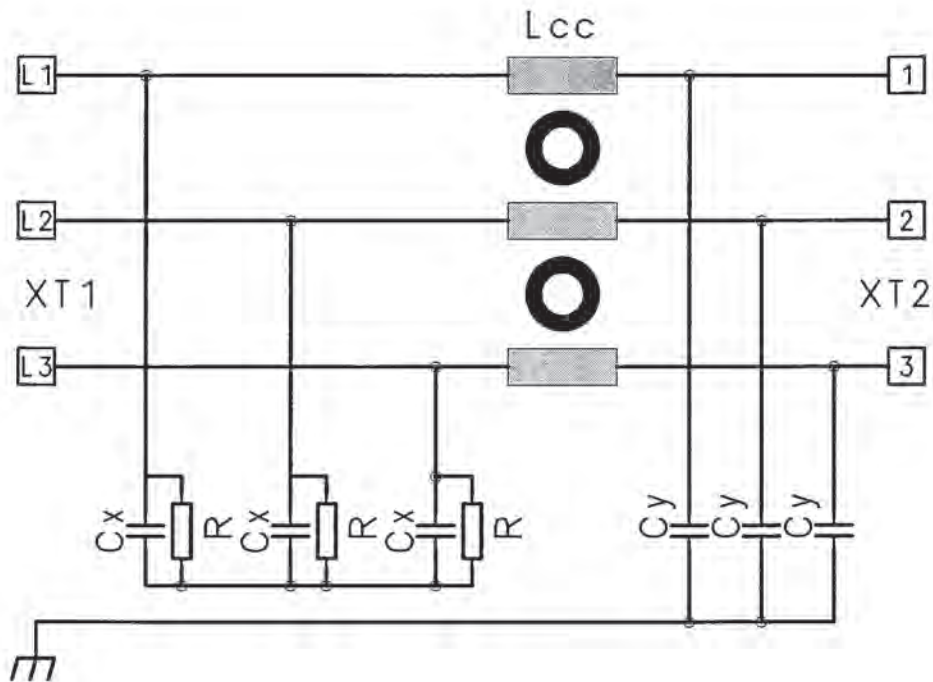
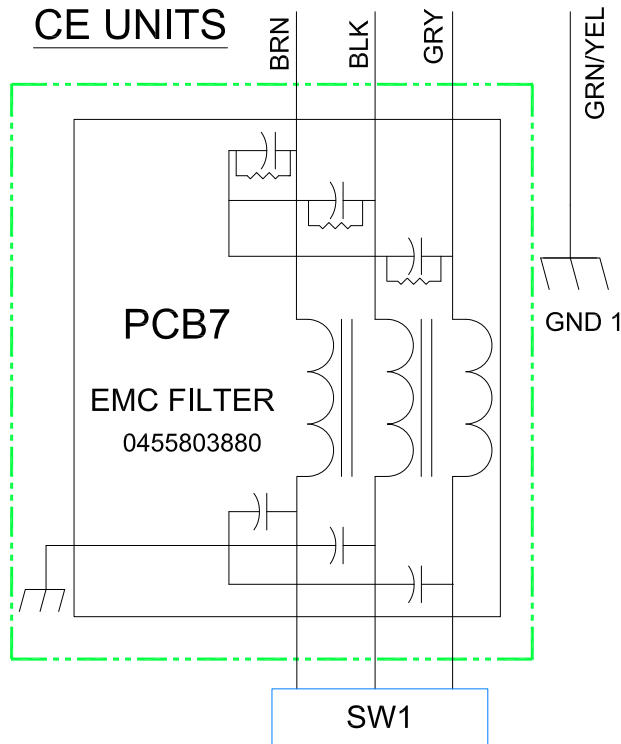

4.17 Solenoid SOL1 (0558007072)

The Gas Solenoid SOL1 is a 24 VAC normally closed gas solenoid rated for 100 PSI. The valve is used as a on/off control for the gas flow through the PC1600.

When the operator activates the torch trigger on the PC1600, the microcontroller on the main control board sends a gas valve command to the power board PCB2. This command closes the contacts of relay RL1, which applies 24 VAC to J13 pin 1 and pin 2 then to the gas solenoid coil.

Test Coil Resistance = 8.5 ohms

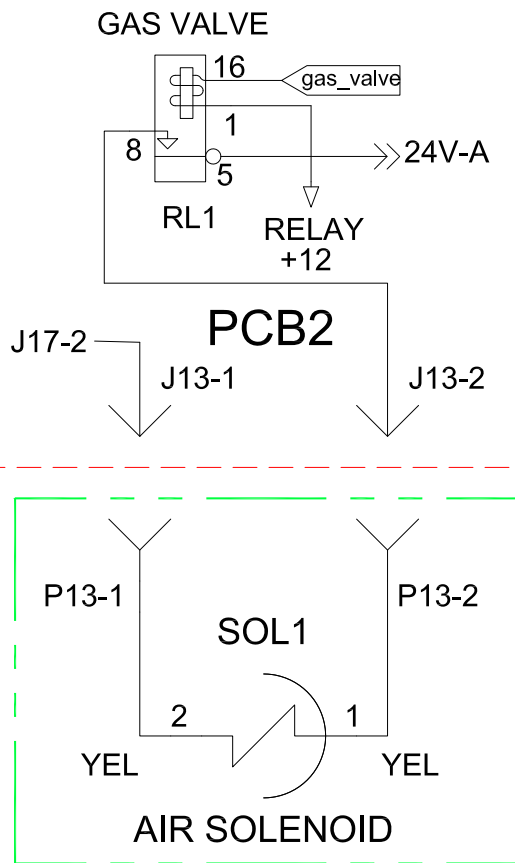

DESCRIPTION

SERIES 50, 24V 50/60Hz
 3 WAY VALVE BODY SINGLE STAGE ASSEMBLY
 1/4 NPT, 3/32" ORIFICE
 1/4" SPADE TERM, 6 WATTS, 100PSI
 NORMALLY CLOSED TO OUTPUT
 MATL: BRASS UNS C36000-H2
 MTG HOLES: 8-32

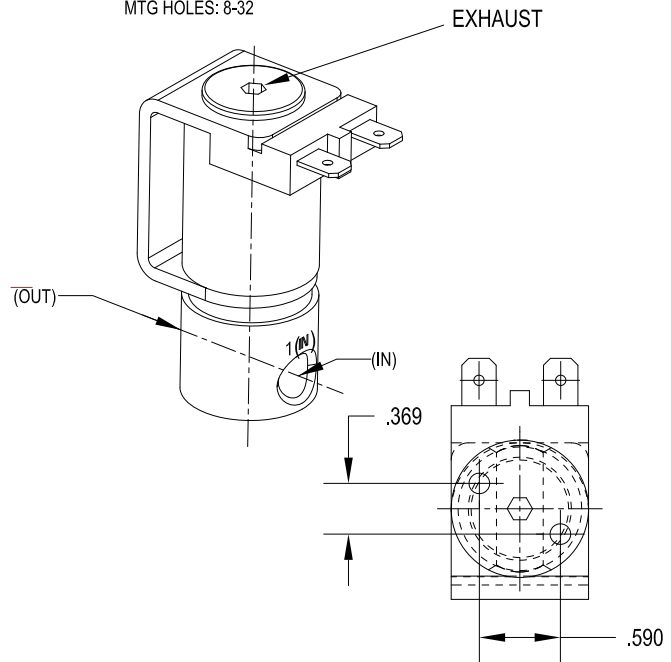

4.18 Remote_PCB6 (0558038337)

The Remote Interface board allows the PC1600 to be controlled by a CNC in a mechanized plasma configuration. This circuit board plugs into the Power Board and has a cable routed from the board to the front panel of the PC1600 for the CNC interface. Reference Mechanized Conversion Kit Installation Instructions for PC-1300/1600 part number 0558008079 for installation and conversion instructions if this unit did not come with this option installed.

This circuit board accepts the following signals from the CNC:

The external reference input is a 0 – 10 VDC signal that is divided by two and sent to the Power Board PCB2 for routing to the Control board PCB1. Reference the schematic.

The start signal will start and stop the power supply on CNC command. Reference the schematic.

The Corner signal is routed to the microcontroller on PCB1. When this signal is sent from the CNC, the microcontroller ramps down the current to a level determined in software.

The ARC ON signal is sent to the CNC from the power supply. When the arc is detected by the PC1600, PCB1 sends an active low signal to PCB6 P1 pin 8 which allows relay RL2 to close. This passes the ARC ON signal out to the CNC.

When the PC1600 detects an internal fault the microcontroller on PCB1 puts an active low on PCB6 P1 pin 7 allowing relay RL1 to close and pass a fault signal out to the CNC.

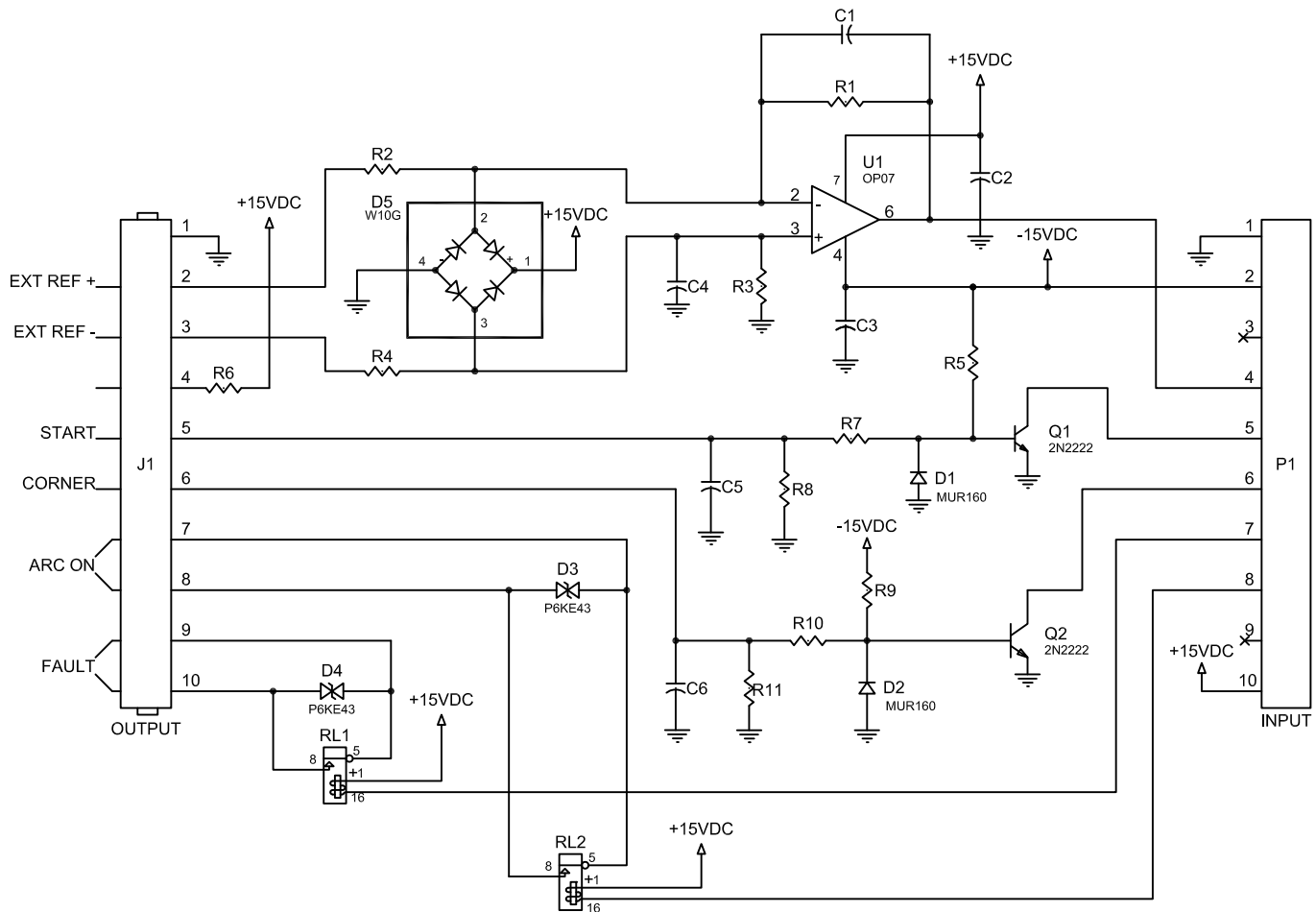

4.18 Remote_PCB6 (0558038337)

0558038337 PCB6 Remote PC Board		
J1		
1	Ground	
2 - 3	Current reference from the CNC	0 - 10 VDC
4	+15 VDC	
5	Start Signal	+15 VDC active
6	Corner	+15 VDC active
7 - 8	ARC ON	Relay contacts for output to CNC
9 - 10	FAULT	Relay contacts for output to CNC

0558038337 PCB6 Remote PC Board		
P1		
1	Ground	
2 - 4	Current reference from the CNC	0 - 5 VDC
5	Start Signal	+15 VDC active
6	Corner	+15 VDC active
7	FAULT	active low to close the relay RL1
8	ARC ON	active low to close the relay RL2

4.18 Remote_PCB6 (0558038337) BOM

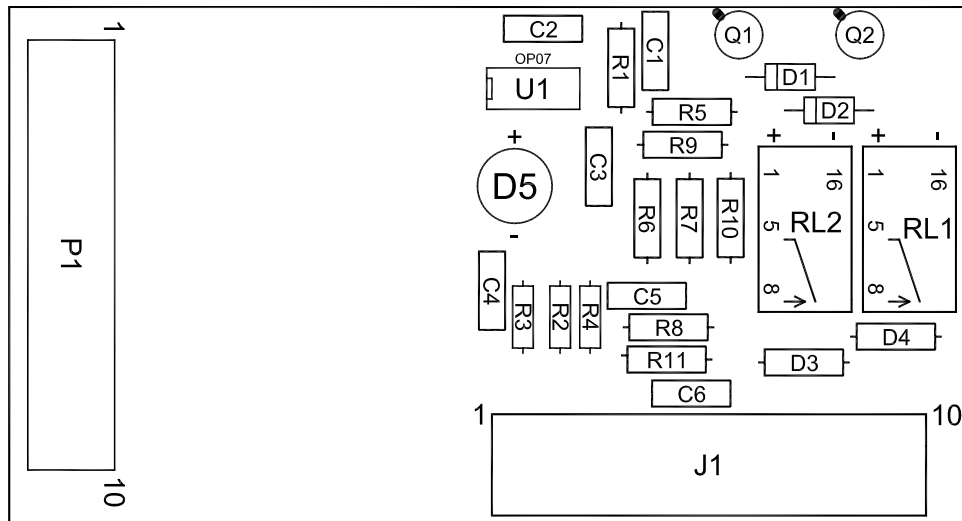

PCB6 (0558038337) Components			
ITEM	SYMBOL	QTY	DESCRIPTION
1		1	DRILLED BOARD
2	C1,C4	2	CAP, 0.001uF, 100VDC, MET-POLY
3	C2,C3	2	CAP, 0.22uF, 100VDC, CERAMIC
4	C5,C6	2	CAP, 0.01uF, 100VDC, MET-POLY
5	D1,D2	2	DIODE, 1A, 600V, MUR160
6	D3,D4	2	DIODE, BI-DIRECTIONAL, P6KE43CA
7	D5	1	DIODE, BRIDGE, 1A, 700V
8	J1	1	HEADER, HORIZ, PHOENIX, 10 PIN
9	P1	1	HEADER CONNECTOR, PHOENIX, 10 POS
10	Q1,Q2	2	TRANSISTOR, 2N2222
11	RL1,RL2	2	RELAY, SPST, 12VDC
12	R1,R3	2	RES, 49.9K, 0.25W, 1%
13	R2,R4	2	RES, 100K, 0.25W, 1%
14	R5,R9	2	RES, 10K, 0.25W, 1%
15	R6	1	RES, 499, 0.25W, 1%
16	R7,R10	2	RES, 1K, 0.25W, 1%
17	R8,R11	2	RES, 4.99K, 0.25W, 1%
18	U1	1	I.C. OP-AMP

SECTION 4

DESCRIPTION OF OPERATION

4.19 PT38 Plasma Torch

Cuts 1-1/2 in. (38 mm); severs 1-3/4 in. (45 mm)
 Current Capacity 90 amps @ 100% duty cycle
 Air Supply 400 cfh @ 80 psig (189 l/min @ 5.5 bar)
 Length of Service Lines 25 (7.6 m) or 50 ft (15.2 m)
 Dimensions
 Overall Length 8.2 in. (208 mm)
 Length of Head 3.0 in. (76 mm)



PT-38 Torch, 25' (7.6 m) 0558006786
 PT-38 Torch, 50' (15.2 m) 0558006787

Torches and torch body assemblies are supplied without electrode, nozzle, heat shield and swirl baffle. Order complete spare parts kits or individual components shown with PT-38 parts breakdown in section 2.3 Spare Parts Kits.

PT-38 Spare Parts Kits			
0558007640 90 AMP PC1600 CE	0558007639 90 AMP PC1600	Part Number	Description
3	3	0558005220	ELECTRODE
1	1	0558005217	GAS BAFFLE 30-70 AMP
1	1	0558004870	GAS BAFFLE 90 AMP
-	-	0558005219	NOZZLE 70 AMP
4	4	0558007680	NOZZLE 90 AMP
1	1	0558007682	NOZZLE DRAG 40 AMP
-	1	0558007549	RETAINING / SHIELD CUP ASSY
1	-	0558006611	RETAINING CUP ASSY w/ THREADS
1	-	0558006602	SHIELD 50-90 AMP
3	3	2064062	O-RING .301ID .070W Nitrile
1	1	17672	GREASE SILICON DOW DC-111 (1/4 oz)
1	1	0558001379	FUSE MIDGET SLO-BLO 2 AMP 600 Volt

SECTION 4

DESCRIPTION OF OPERATION

4.19 PT38 Plasma Torch



Nozzle and Retaining Cup Assembly

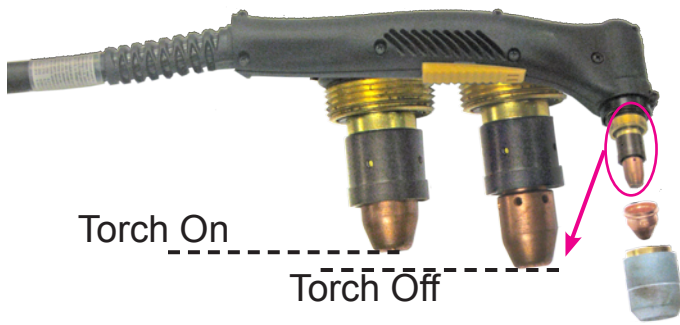

Torch On

Torch Off



Nozzle

90A = 0558007680

70A = 0558005219

40A = 0558007682

Electrode
0558005220

Retaining Cup
0558007549



Gas Baffle

90A = 0558004870

40-70A = 0558005217



Handle Set
0558006735

Screw Blk Ox #6 x .5 Long
61950852

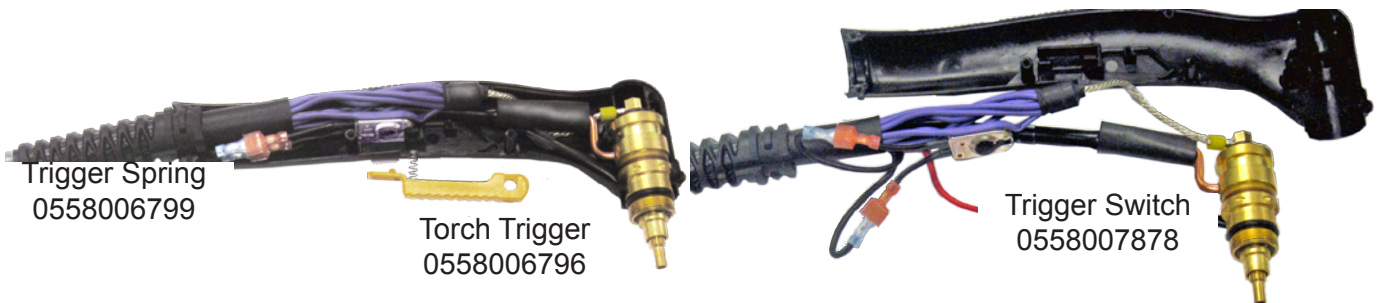

Trigger Spring
0558006799

Torch Trigger
0558006796

Trigger Switch
0558007878

4.19 PT38 Plasma Torch

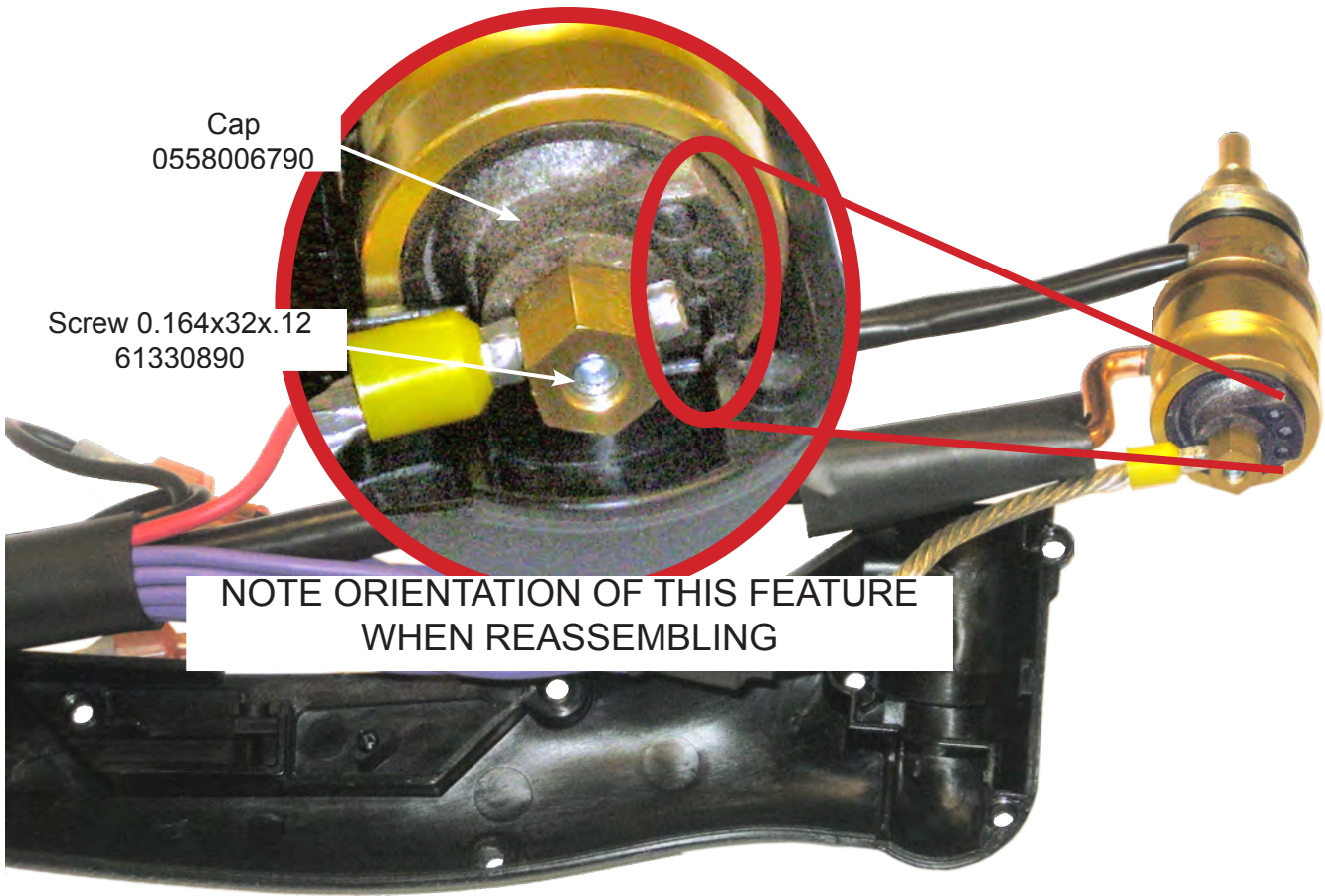

NOTE: DO NOT HEAT SHRINK SLEEVES
WHEN REASSEMBLING

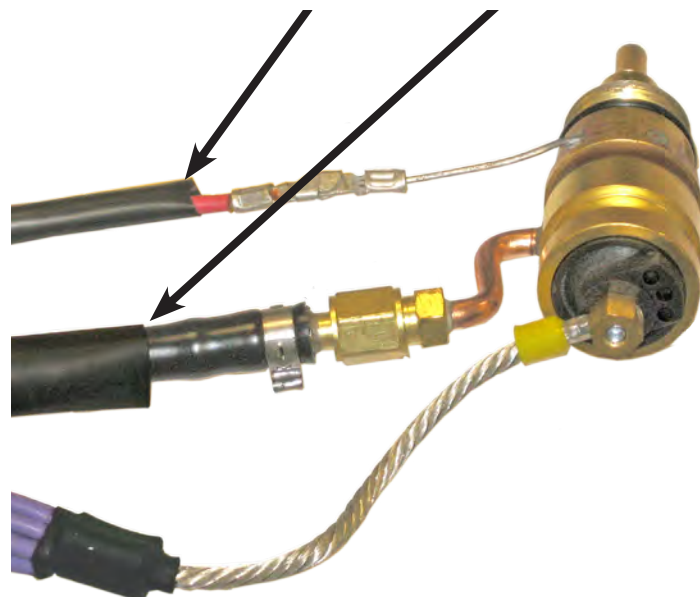

4.19 PT38 Plasma Torch



SECTION 4

DESCRIPTION OF OPERATION

4.19 PT38 Plasma Torch

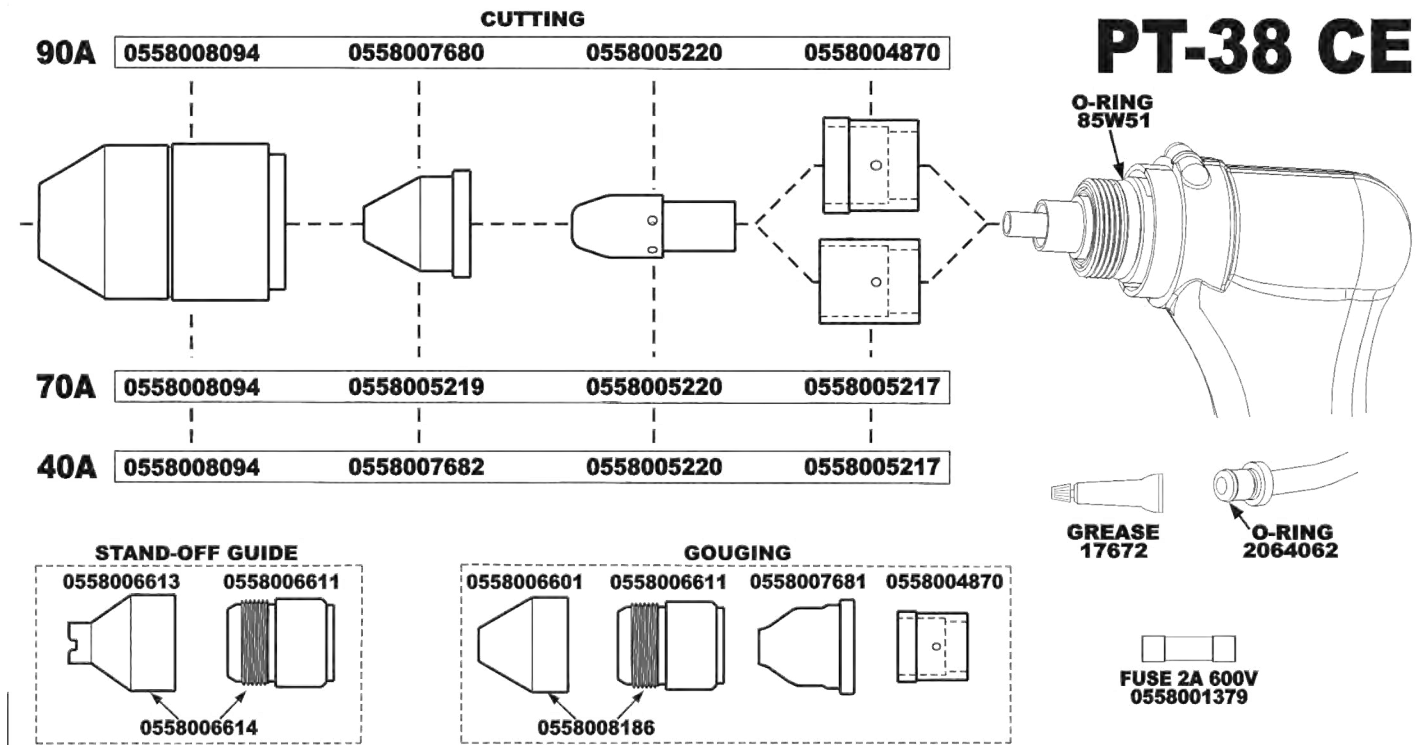
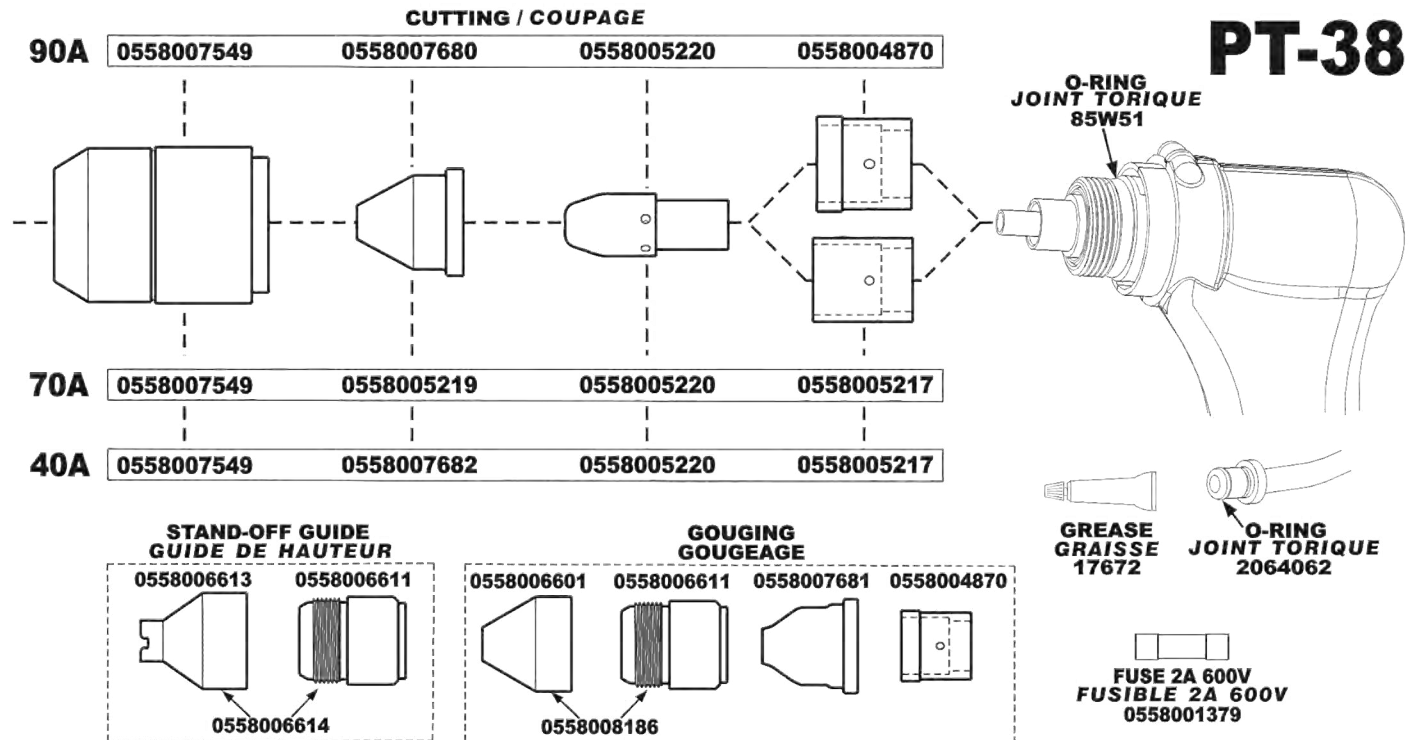

SECTION 4

DESCRIPTION OF OPERATION

4.19 PT38 Plasma Torch

ESAB P/N	DESCRIPTION
0558006786	PT-38 TORCH AY 25FT
0558006787	PT-38 TORCH AY 50FT

NOTES:

1. GREASE ALL O-RINGS PRIOR TO INSTALLATION.
2. ASSEMBLE IN CLEAN ENVIRONMENT AREA
3. INSURE FREE MOTION OF PISTON AND CABLE

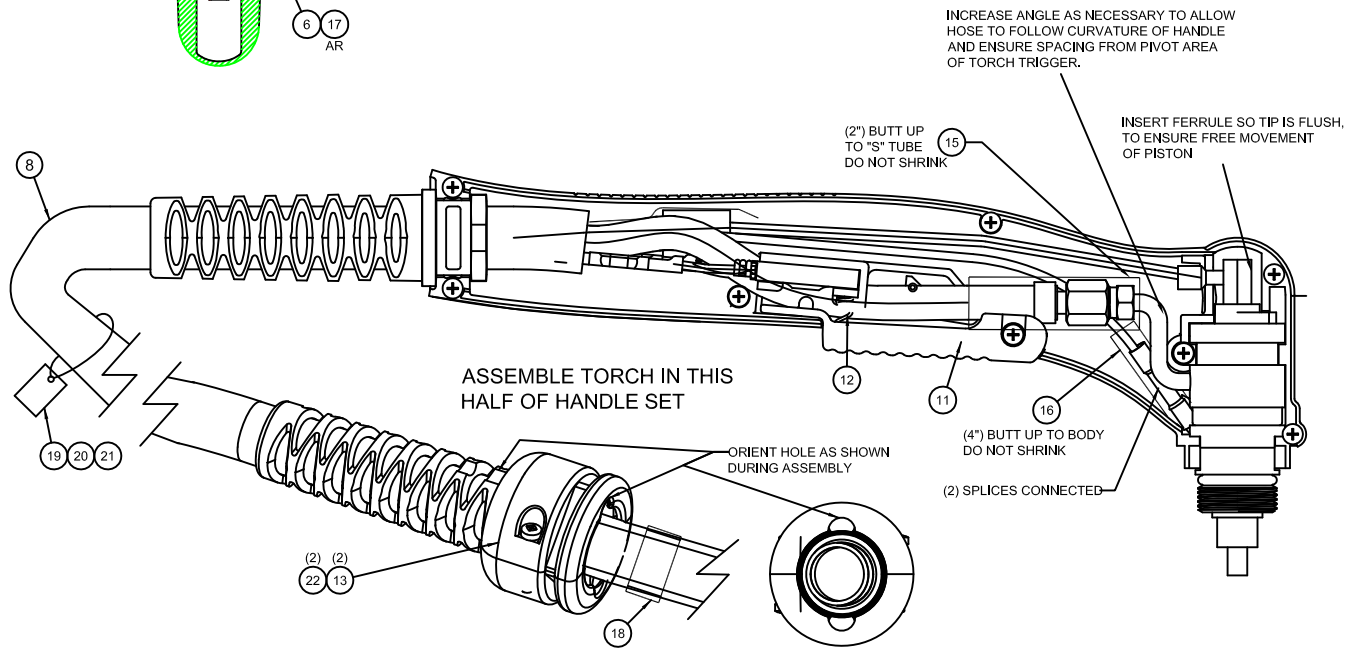
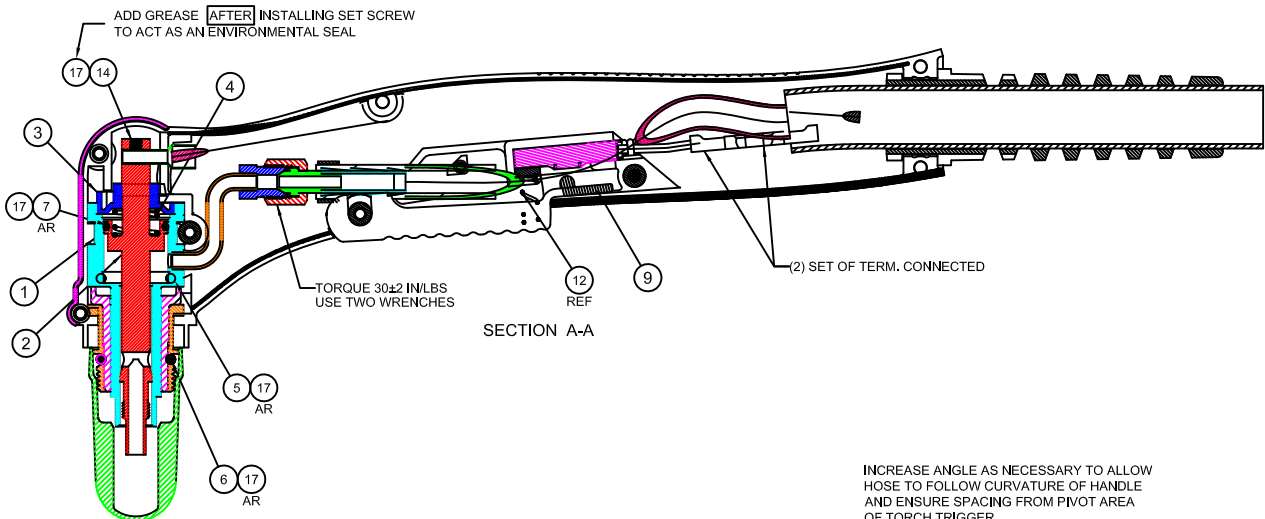
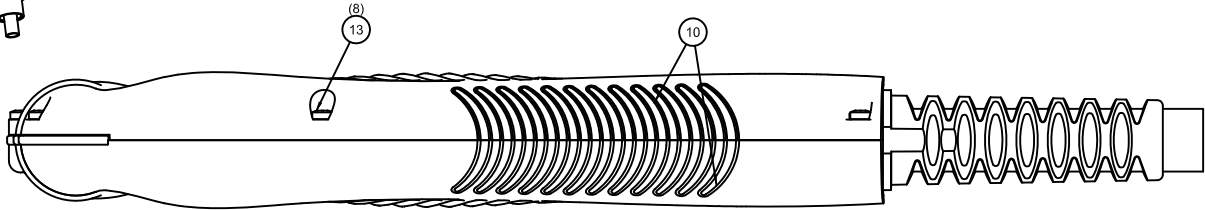
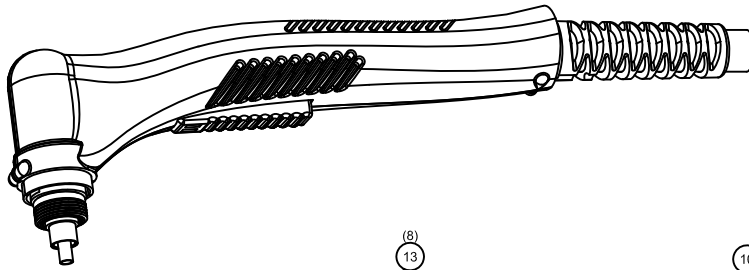

SECTION 4**DESCRIPTION OF OPERATION****4.19 PT38 Plasma Torch**

PT38 REPLACEMENT PARTS			
ITEM	QTY	P/N	DESCRIPTION
1	1	0558006789	BODY BRAZED PT-38
2	1	0558006791	PISTON PT-38
3	1	0558006790	CAP PT-38
4	1	0558006234	SPRING ELECTRODE CONTACT 100A
5	1	5W07	O-RING 0.549 ID X .103 CR
6	1	5W51	O-RING 0.674 ID X .103 CR
7	1	2223489	O-RING 0.590 ID X .070 FLUOR 70A
8	1	0558006800	CABLE POWER AY 25FT PT-38 _ (Torch PN 0558006786)
	1	0558006801	CABLE POWER AY 50FT PT-38_ (Torch PN 0558006787)
9	1	0558007878	SWITCH AY TRIGGER PT-38
10	1	0558006795	HANDLE SET PT-38
11	1	0558006796	TORCH TRIGGER PT-38
12	1	0558006799	SPRING TRIGGER PT-38
13	10	61950852	SCR BLK OX #6 X .500LG
14	1	61330890	SCR 13011 STLZPC 0.164-32X0.12
15	.17'	90863001	HEATSHRINK SEM-RIGID 1/2" BLACK
16	.34'	90862534	TUBING PVC, 300V, #4 BLACK
17	AR	77500101	SILICON DOW DC-111 5.3 OZ.
18	1	0558954061	LABEL PATENT TORCH (BILINGUAL)
19	1	953833	TAG TORCH WARNING OEM MACHINE (BILINGUAL)
20	1	954063	TAG TEXT WARNING FUME SHOCK ARC
21	1	0558954086	TAG TEXT WARNING FUME SHOCK ARC (FRENCH)
22	2	0558007460	STRAIN RELIEF-HALF

SECTION 5

WIRING DIAGRAMS

5.1 Wiring Diagram 230/460 Volt (0558007543)

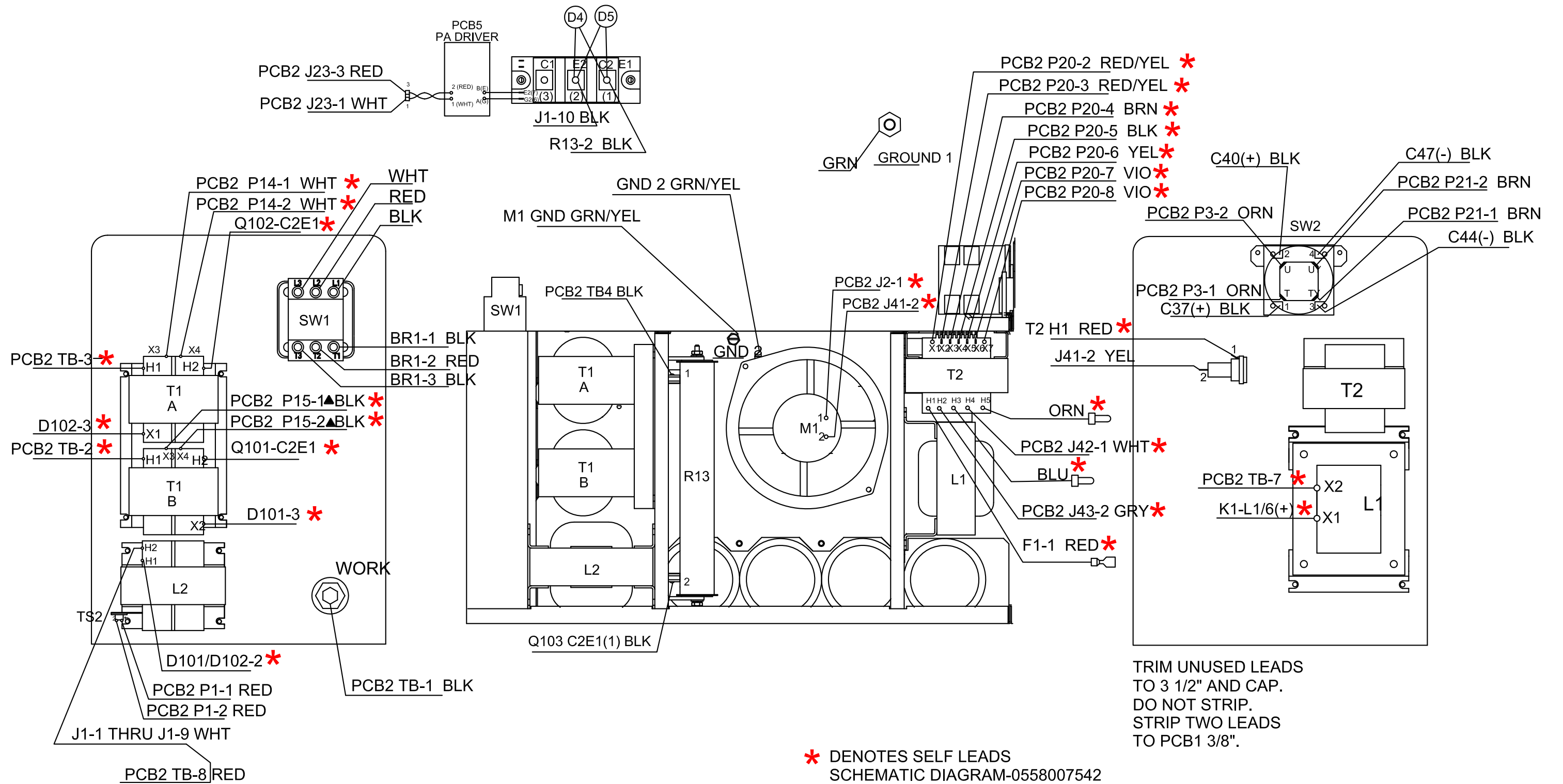

SECTION 5

WIRING DIAGRAMS

5.1 Wiring Diagram 230/460 Volt (0558007543)

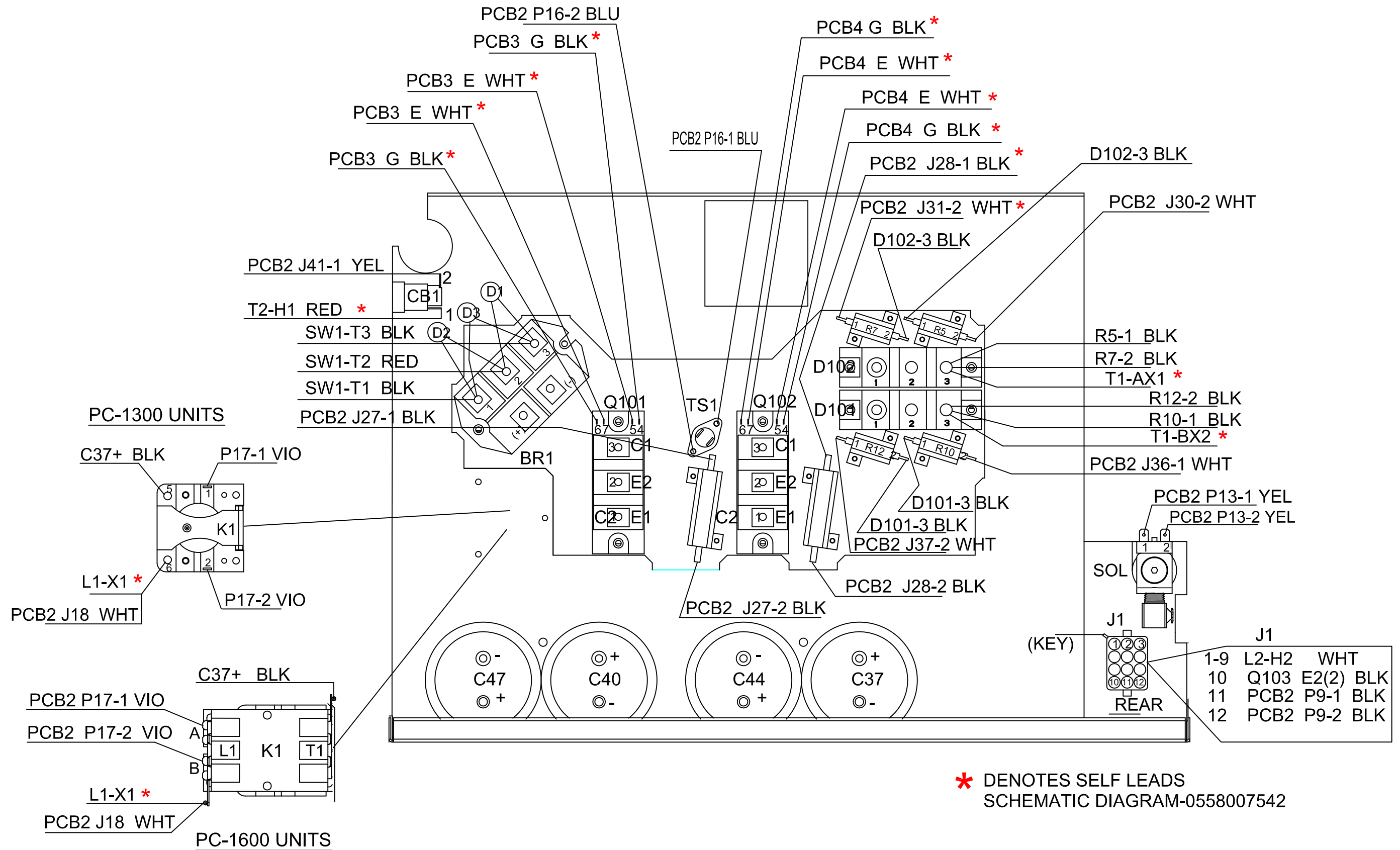

SECTION 5

WIRING DIAGRAMS

5.1 Wiring Diagram 230/460 Volt (0558007543)

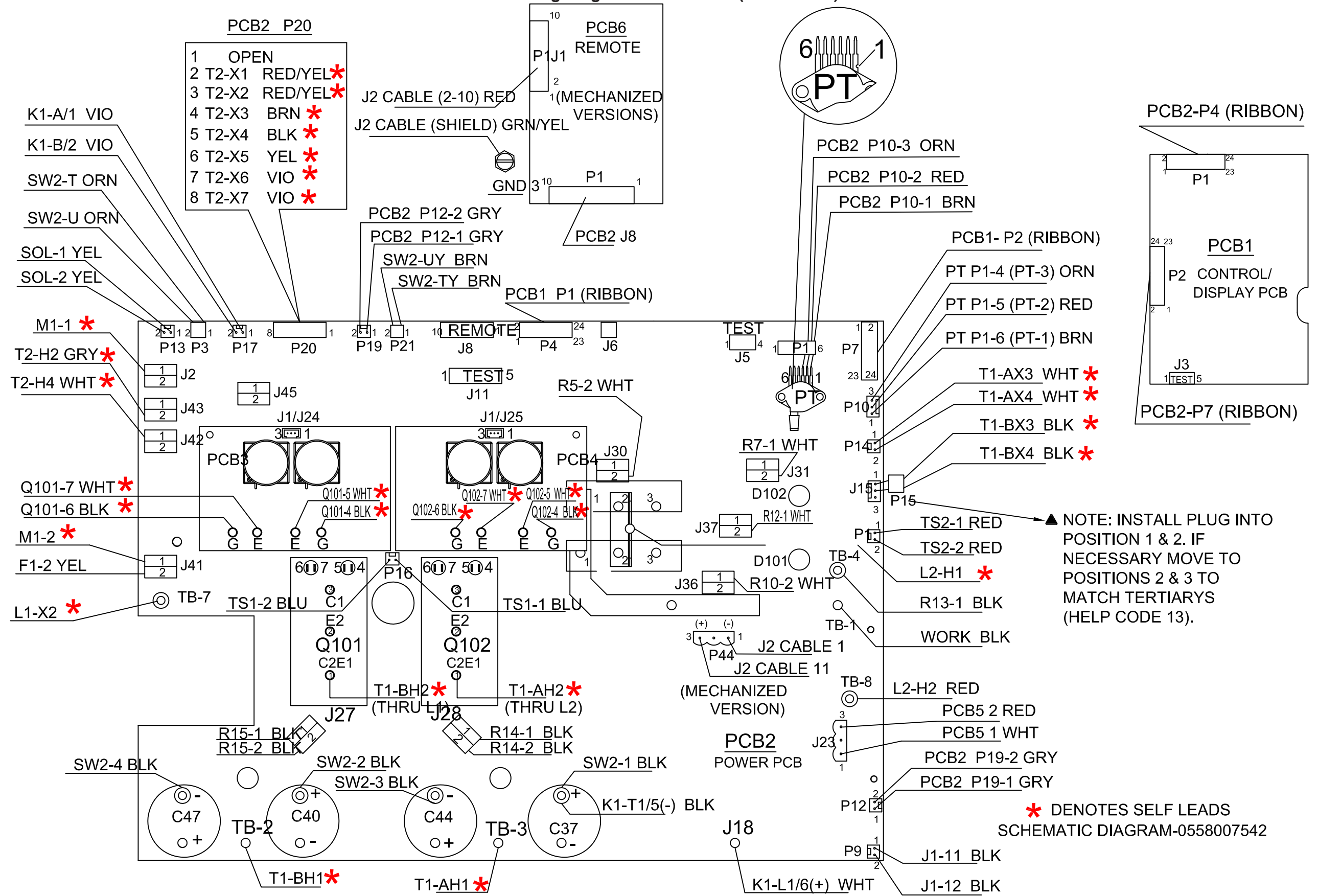

SECTION 5

WIRING DIAGRAMS

5.2 Wiring Diagram 400/400V CE (0558007547)

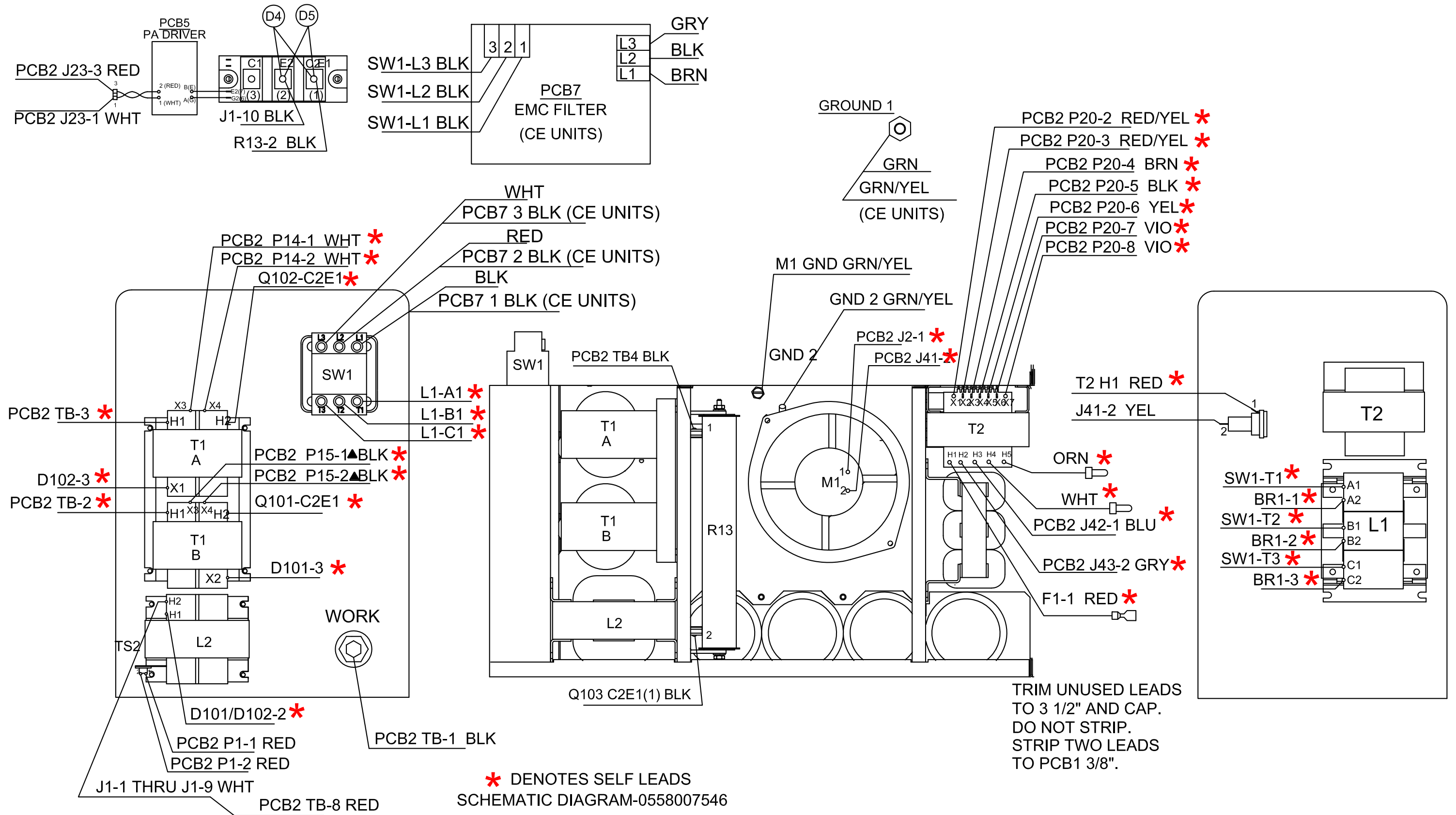

SECTION 5

WIRING DIAGRAMS

5.2 Wiring Diagram 400/400V CE (0558007547)

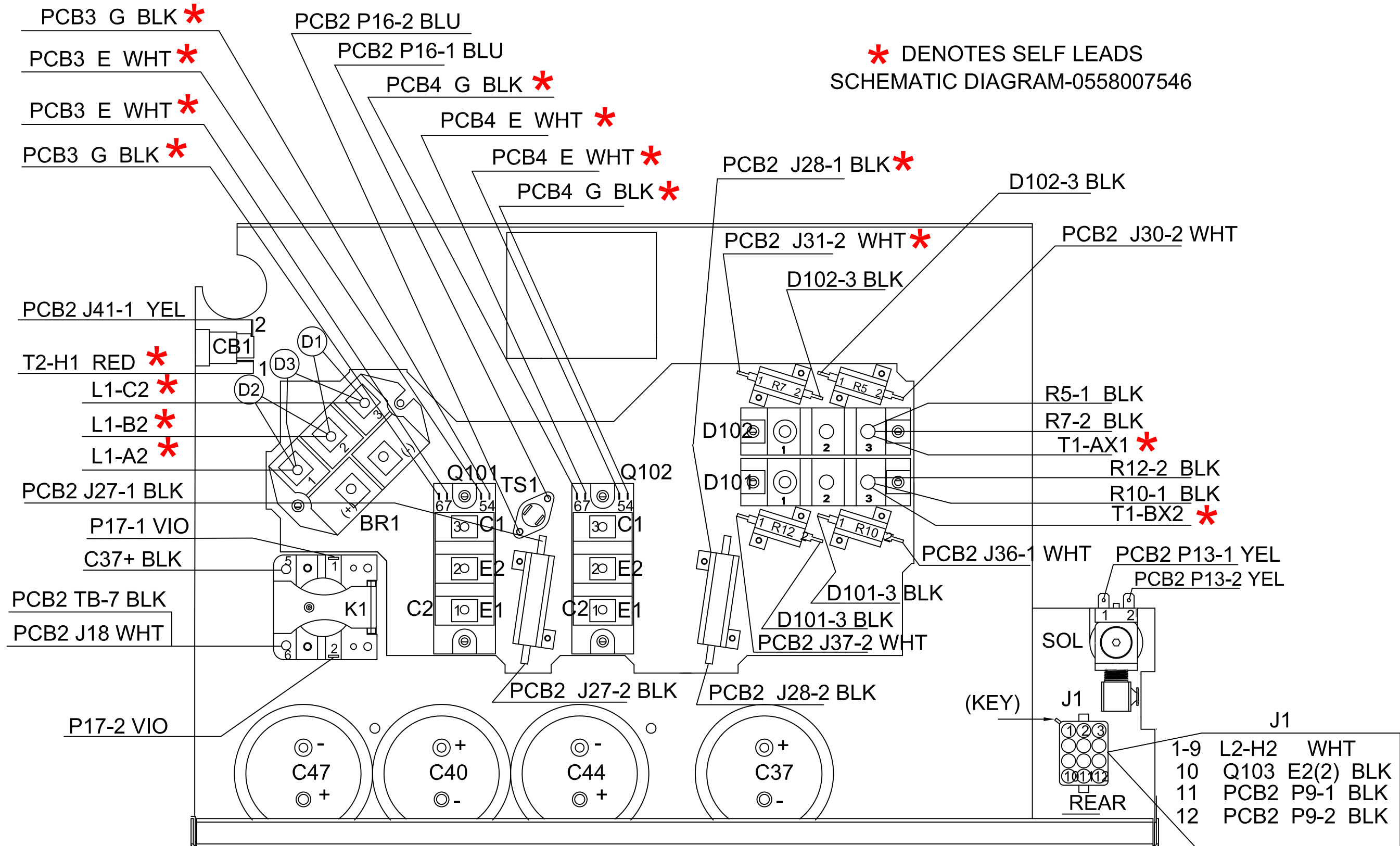

SECTION 5

WIRING DIAGRAMS

5.2 Wiring Diagram 400/400V CE (0558007547)

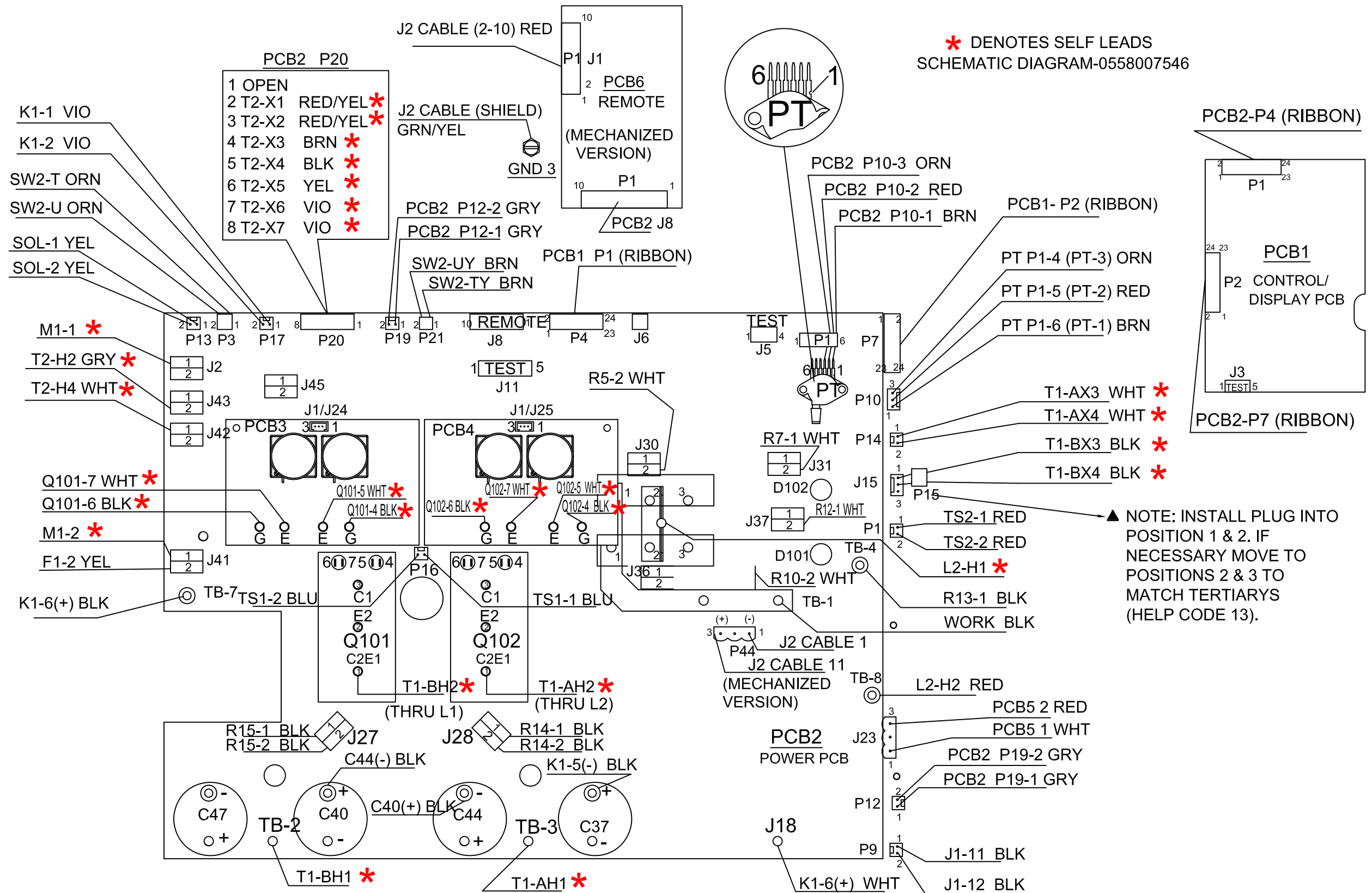

SECTION 5

WIRING DIAGRAMS

5.3 Wiring Diagram 575V (0558007545)

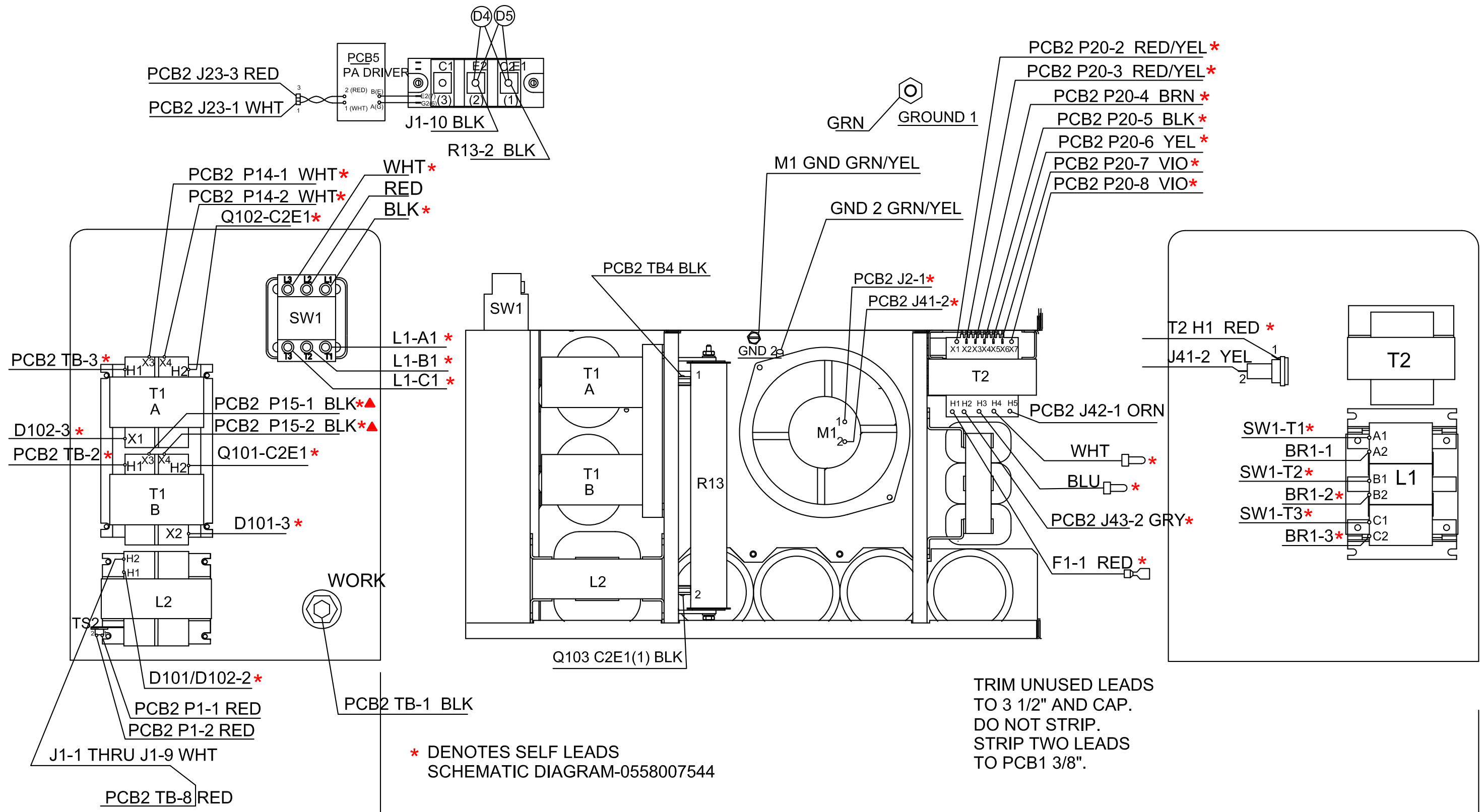

SECTION 5

WIRING DIAGRAMS

5.3 Wiring Diagram 575V (0558007545)

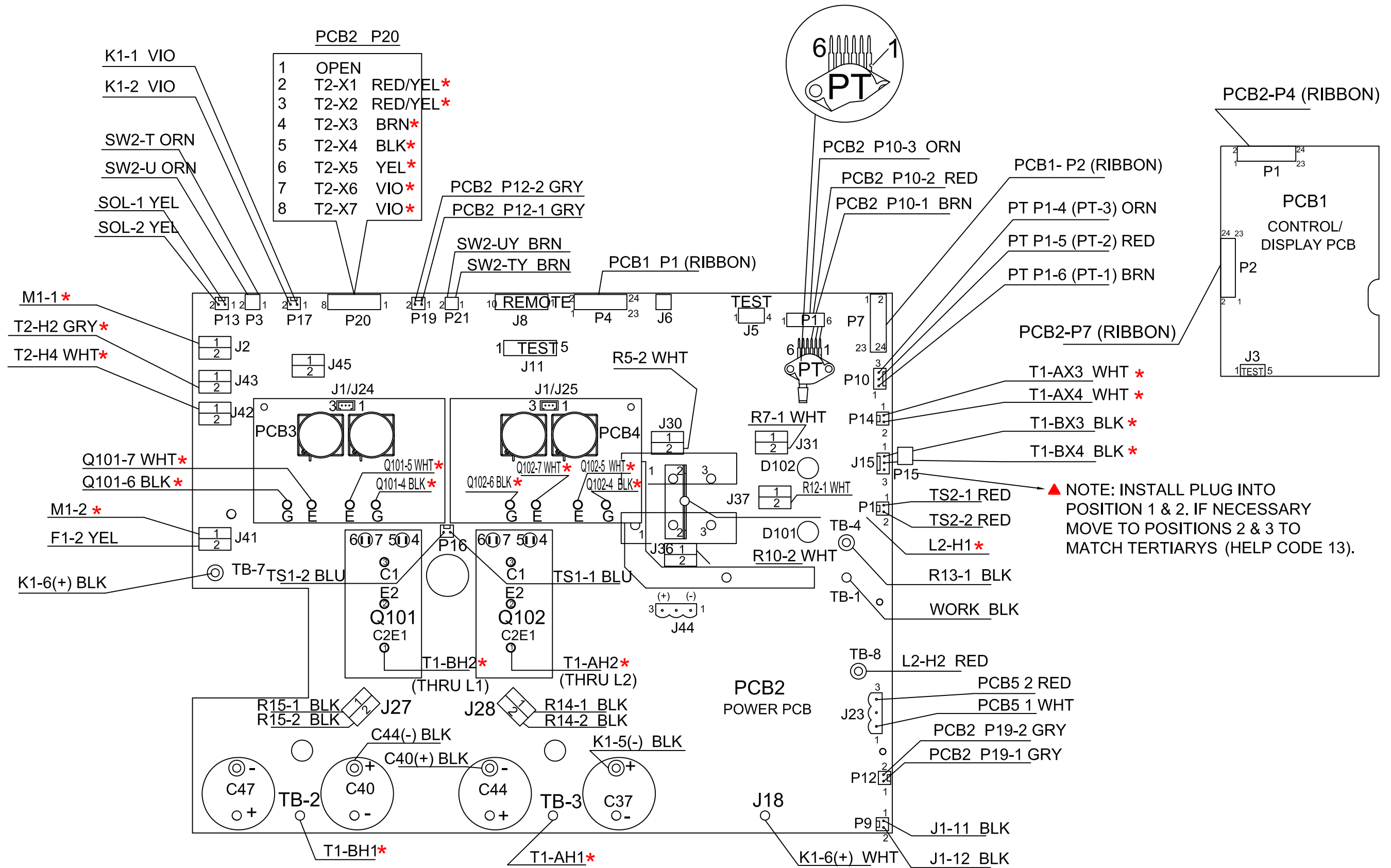

SECTION 5

WIRING DIAGRAMS

5.3 Wiring Diagram 575V (0558007545)

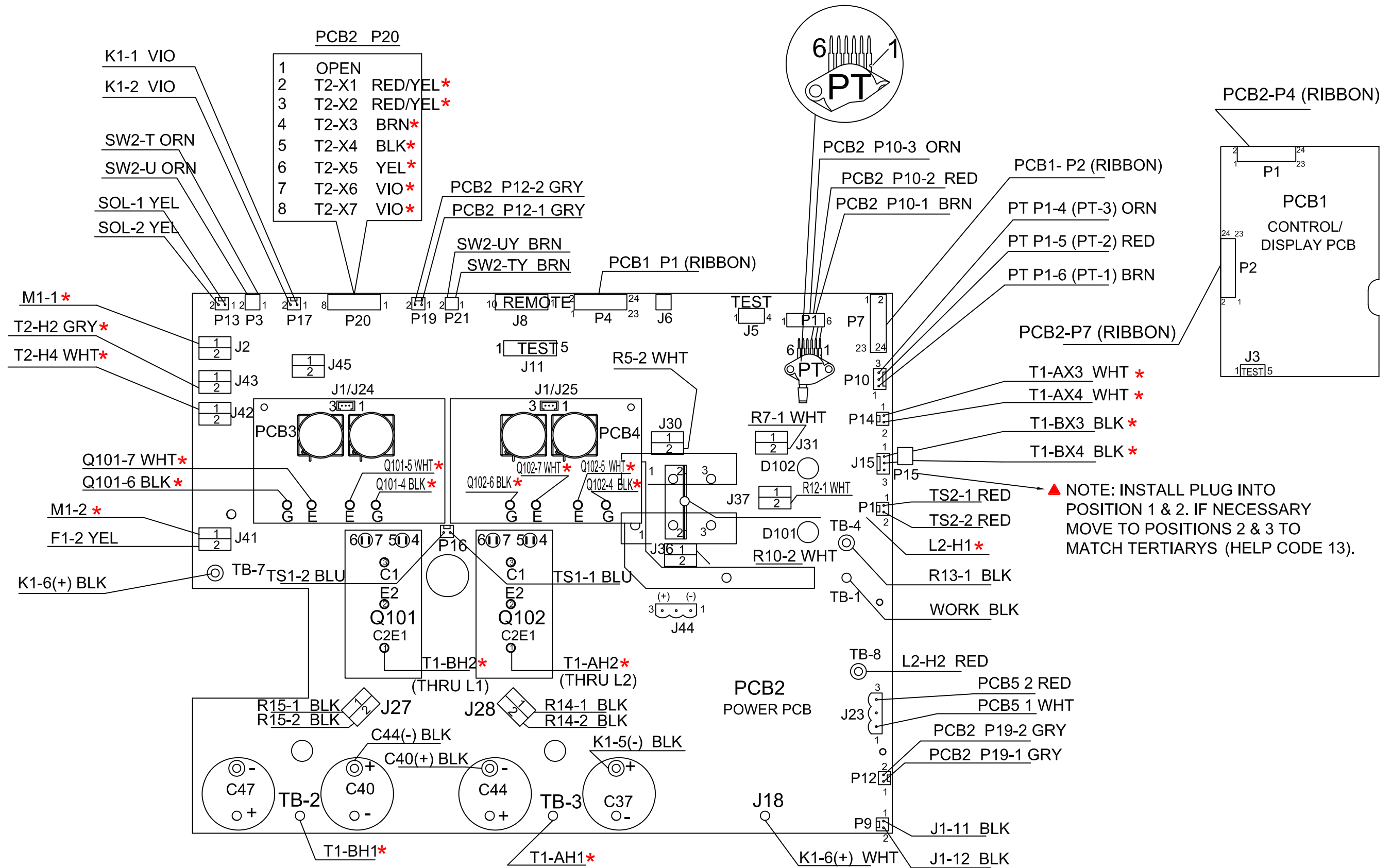

BLANK

6.0 REPLACEMENT PARTS

6.1 General

Always provide the serial number of the unit on which the parts will be used. The serial number is stamped on the unit nameplate.

6.2 Ordering

To ensure proper operation, it is recommended that only genuine ESAB parts and products be used with this equipment. The use of non-ESAB parts may void your warranty.

Replacement parts may be ordered from your ESAB Distributor.

Be sure to indicate any special shipping instructions when ordering replacement parts.

Refer to the Communications Guide located on the back page of this manual for a list of customer service phone numbers.

NOTE

Bill of material items that have blank part numbers are provided for customer information only. Hardware items should be available through local sources.

SECTION 6

REPLACEMENT PARTS

6.0 Replacement Parts _ Left Side

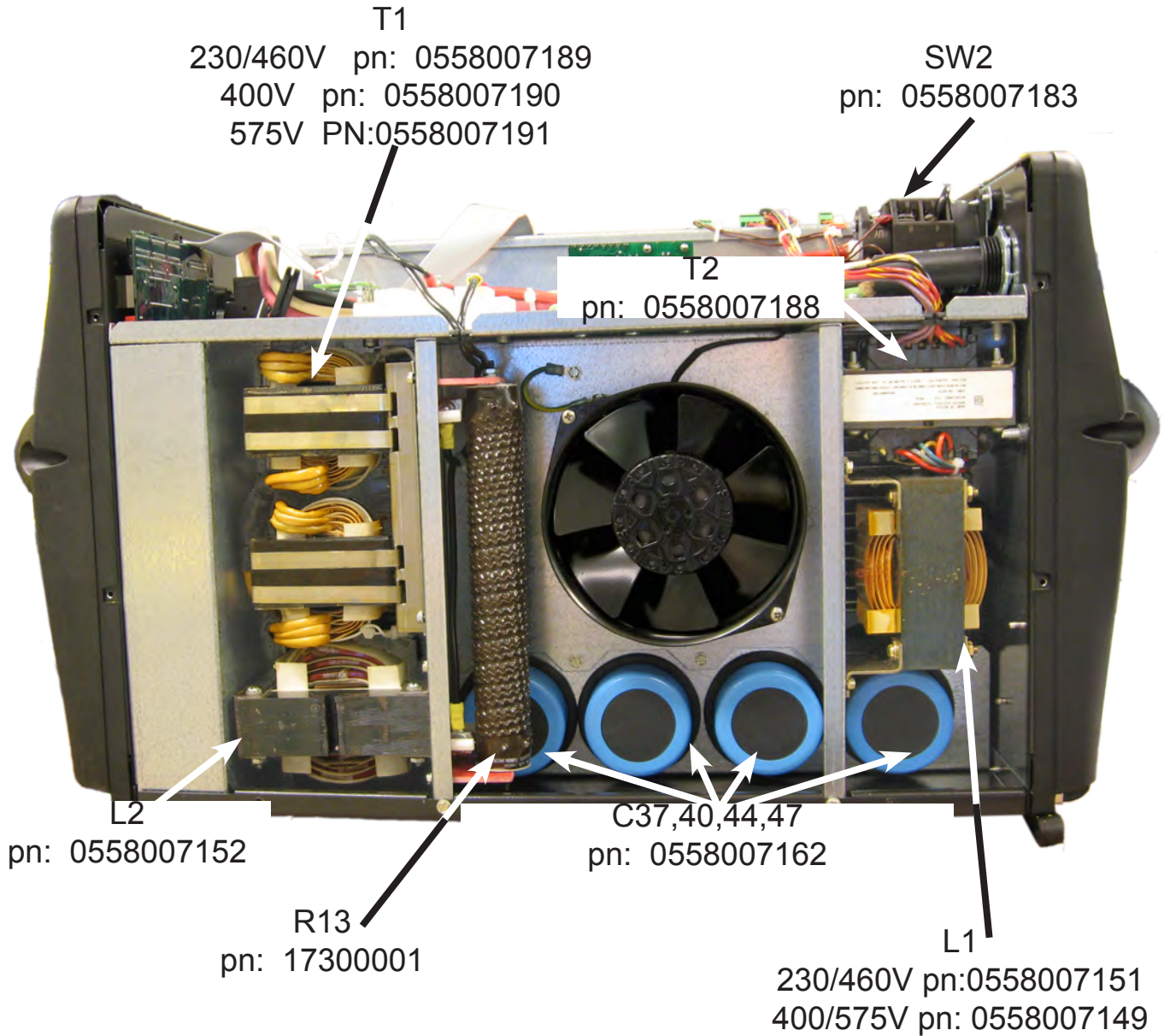

SECTION 6

REPLACEMENT PARTS

6.0 Replacement Parts _ Right Side

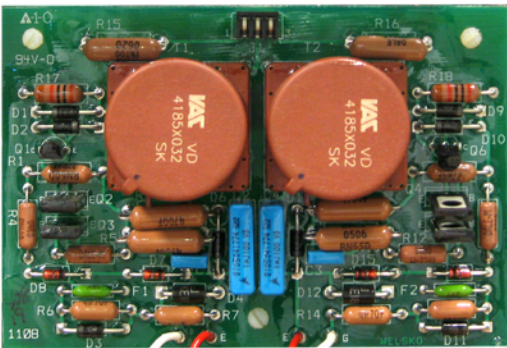

PRESSURE TRANSDUCER
pn: 0558006148

PCB3, PCB4
pn: 0558038335

PCB2

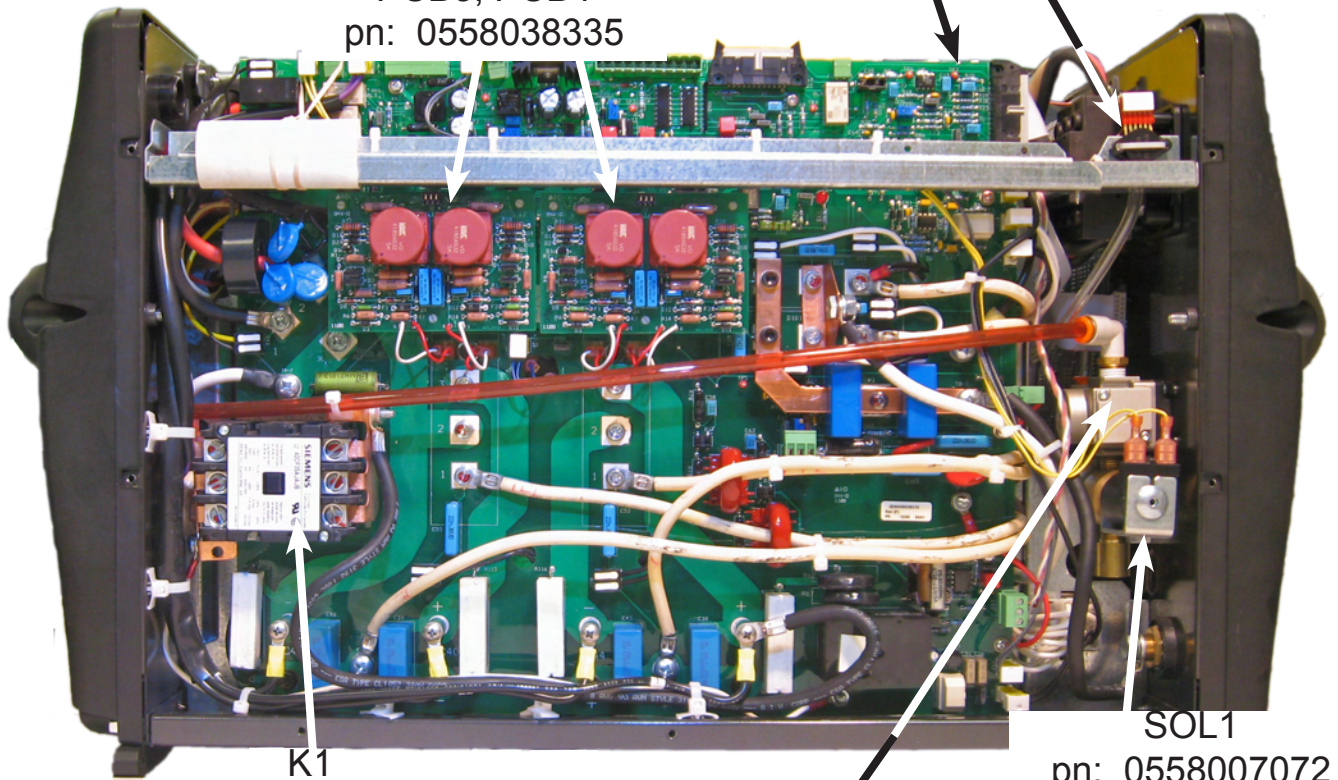

SOL1
pn: 0558007072

PRESSURE REGULATOR
pn: 0558007071

K1

6.0 Replacement Parts _ Top

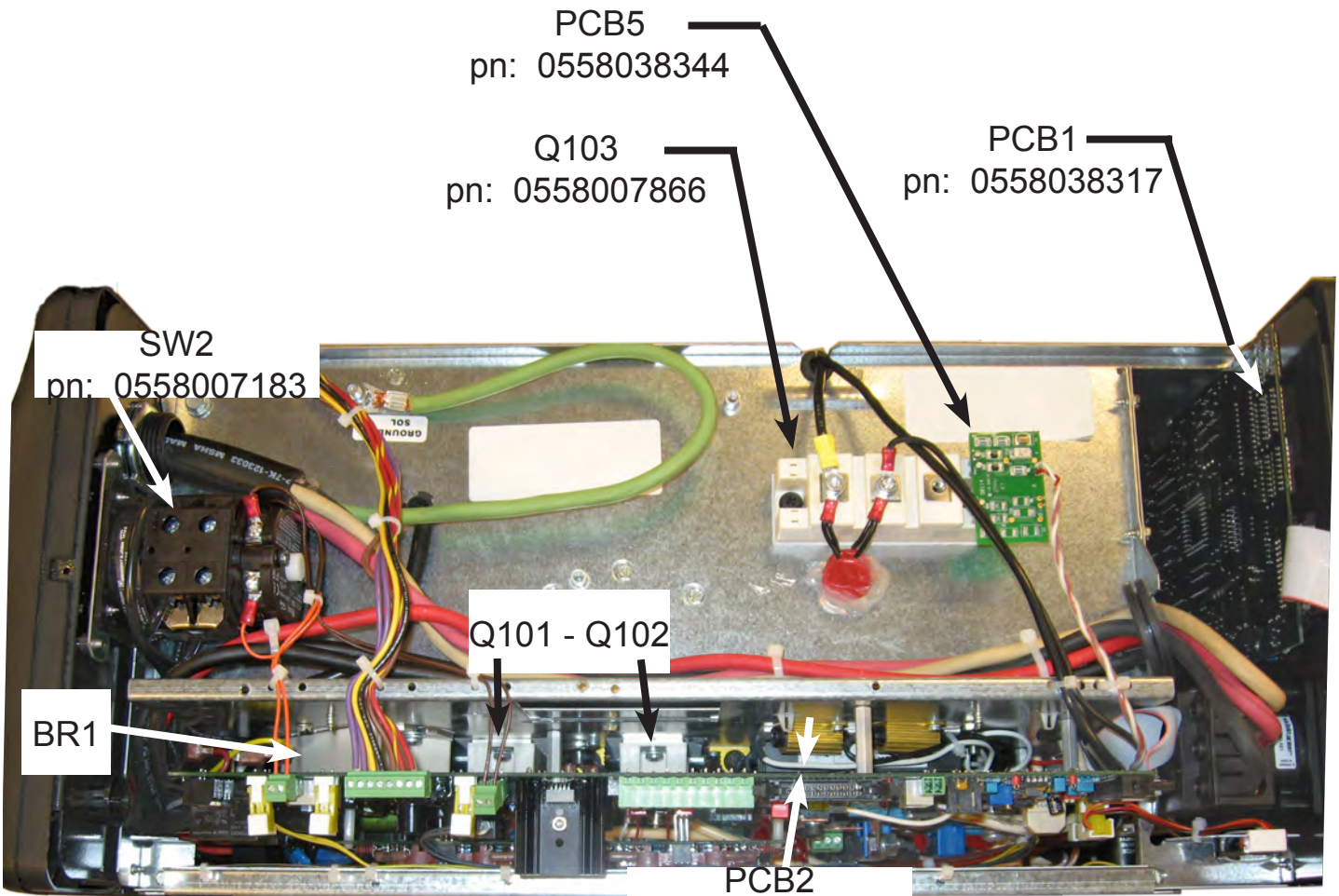

SECTION 6

REPLACEMENT PARTS

6.3 Front (0558007540)

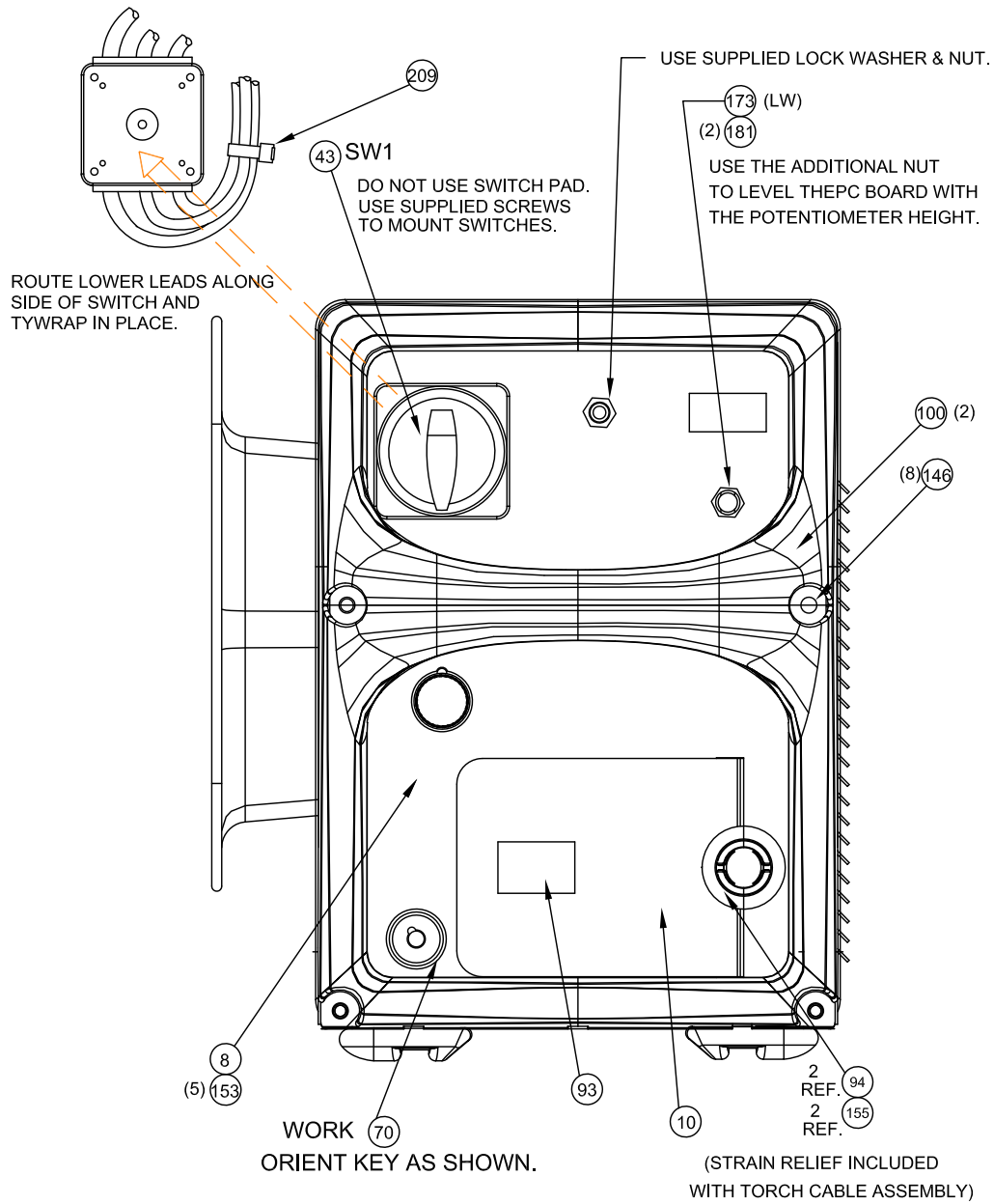

6.3 Fan Kit (0558008454)

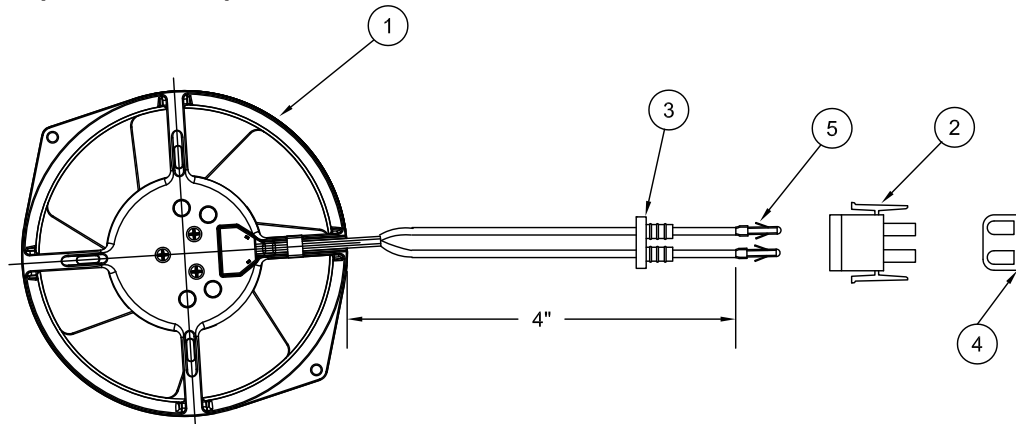

SECTION 6**REPLACEMENT PARTS****6.3 Front BOM**

PC1600 REPLACEMENT PARTS				
ITEM	QTY	P/N	DESCRIPTION	SYMBOL
2	1	0558007202	BRACKET FAN	
8	1	0558007197M	PANEL FRONT	
10	1	0558007205M	DOOR ACCESS	
43	1	36107	SWITCH POWER 3P 60A 600V	SW1
70	1	0558007074	SOCKET PANEL MINI 250A	WORK
93	1	0558007069	LATCH SLIDING	
94	Ref	0558007460	STRAIN RELIEF HALF Torch Cable	
100	2	0558006911	END CAP / HANDLE	
146	AR	61328090	SCREW HE WSH TRI 1/4-20 1.00	
153	AR	61327747	SCREW HE WSH TAP #8 .4 RIBBED	
155	Ref	61950852	SCREW PHL PAN TAP #6 .50 BIK	
173	AR	0558007893	WASHER LOCK INT 15/32	
181	AR	0558007894	NUT 15/32-32	
209	AR	180W66	TYWRAP LG 7.25"	

6.3 Fan Kit BOM

PC1600 REPLACEMENT PARTS			
ITEM	QTY	P/N	DESCRIPTION
1	1	0558008438	FAN 6" 250CFM 230V
2	1	0558001012	HOUSING UNIV PLUG 2 POS-WHT
3	1	0558001014	SEAL WIRE UNIV HOUSING 2 POS
4	1	0558001015	SEAL INTERFACE UNIV HOUSING 2 POS
5	2	2062346	CONTACT, SOCKET, 20-14 AWG - ROUND

SECTION 6

REPLACEMENT PARTS

6.3 Right Interior View (0558007540)

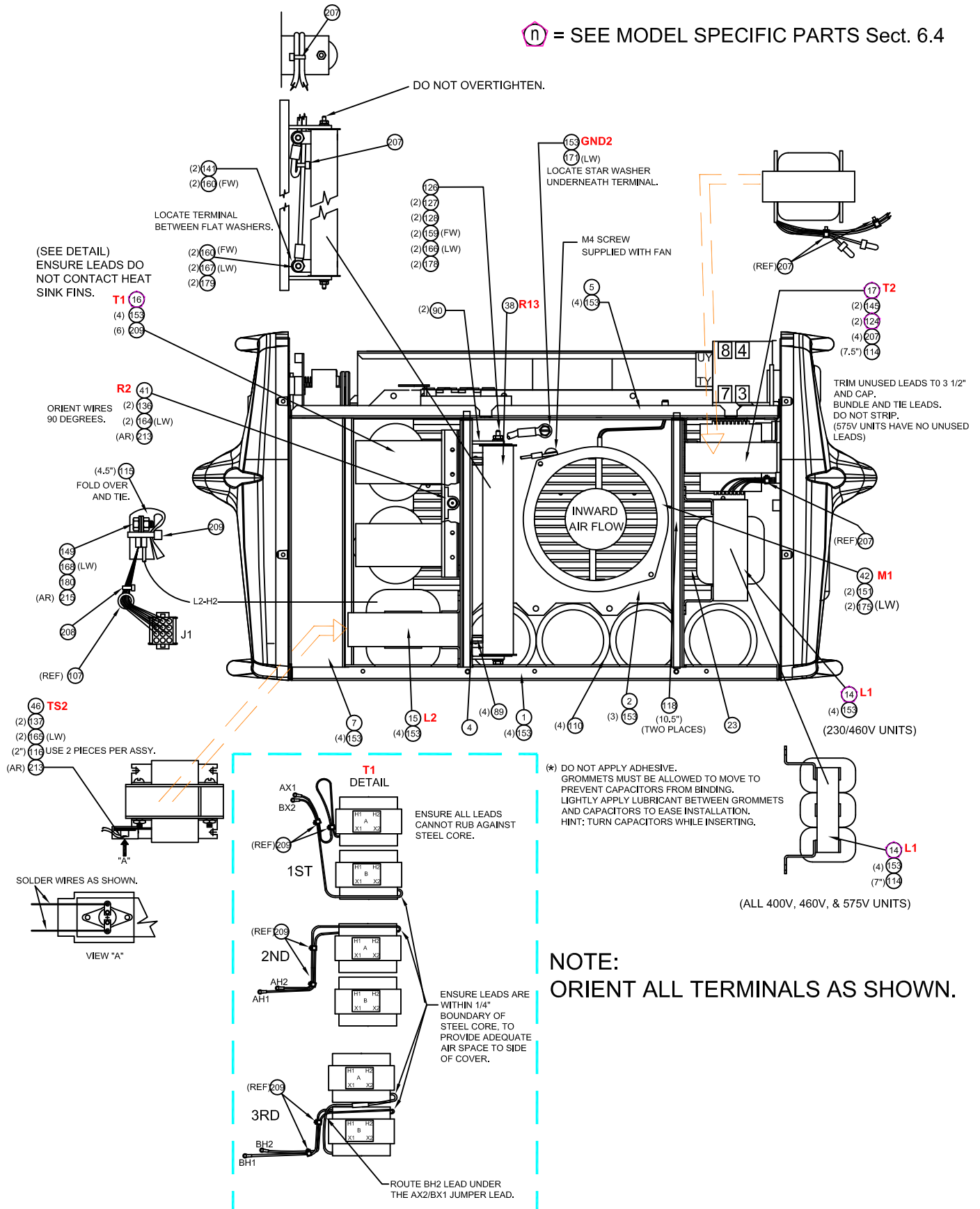

SECTION 6

REPLACEMENT PARTS

6.3 Right Interior View BOM

PC1600 REPLACEMENT PARTS				
ITEM	QTY	P/N	DESCRIPTION	SYMBOL
1	1	0558007196M	BASE	
2	1	0558007202	BRACKET FAN	
4	1	0558007201	BRACKET FMR	
5	1	0558007203	SHELF	
7	1	0558007204	BO PCB	
14	SEE SECT 6.4		INDUCTOR INPUT	L1
15	1	0558007152	INDUCTOR OUTPUT	L2
16	SEE SECT 6.4		FMR MAIN 230/460V	T1
17			FMR CONTROL 208/230/400/460V	T2
23	1	0558007154	HEATSINK (SCREEN TOOL 0558954072)	
38	1	17300001	RESISTOR 1 OHM 300W	R13
41	1	17712001	RESISTOR 0.1 OHM 25W 5%	R2
42	1	0558008454	KIT FAN 6" 230CFM 230V w/ PLUG	M1 / P3
46	1	0558007892	SWITCH THERMAL N/C 176°F - Solder	TS2
89	4	0558007212	STANDOFF NYLON FEMALE #6-32 HE 3/4" LG	
90	2	0558007211	BRACKET ANGLE GLASTIC	
107	1	993837	GROMMET RUBBER 0.44ID 0.56GD .06W	
110	8	0558007070	GROMMET RUBBER 2.50ID 2.75GD .06W	
114	1.63'	99510498	TUBING PVC, 600V, 1/2" BLACK	
115	.38'	2132496	TUBING PVC, 600V, 5/8" BLACK	
116	.33'	90863100	HEATSHRINK 1" BLACK	
118	1.75'	22529001	STRIP RUBBER FOAM 0.25 WIDE .063 THK.	
124	2	634736	TERM, WIRE JOINT INS, 18-16 AWG	
126	1	46N08	ROD THREADED #8-32 9.75" LG	
127	2	647182	WASHER INSULATING MICA	
128	2	91W19	WASHER CENTERING	
136		61325826	SCREW SQ PAN TRI #4-40 .38	
137	AR	61325849	SCREW SQ PAN TRI #6-32 .25	
141	AR	61325902	SCREW SQ PAN TRI #10-24 .50	
145	AR	61328087	SCREW HE WSH TRI 1/4-20 .50	
149	AR	61341087	SCREW HE CAP 1/4-20 .50	
151	2	04S04060	SCREW PHL PAN SST M4 60	
153	AR	61327747	SCREW HE WSH TAP #8 .4 RIBBED	
159	AR	64304887	WASHER FLAT #8	
160	AR	64304050	WASHER FLAT #10	
164	AR	64302837	WASHER LOCK #4	
165	AR	64302860	WASHER LOCK #6	
166	AR	64302887	WASHER LOCK #8	
167	AR	64302920	WASHER LOCK #10	
168	AR	64302996	WASHER LOCK 1/4	
171	AR	64307887	WASHER LOCK ET #8	
175	AR	04W10041	WASHER LOCK M4	
178	AR	63300886	NUT #8-32	
179	AR	63300916	NUT #10-24	
180	AR	63300100	NUT 1/4-20	
207	AR	180W68	TYWRAP SM 4"	
208	AR	631507	TYWRAP MED 5.5"	
209	AR	180W66	TYWRAP LG 7.25"	
213	AR	76200103	SOLDER .031 DIA	
215	AR	73585980	COMPOUND ELECTRICAL JOINT ALCOA #2	

SECTION 6

REPLACEMENT PARTS

6.3 Top (0558007540)

(N) = SEE MODEL SPECIFIC PARTS Sect. 6.4

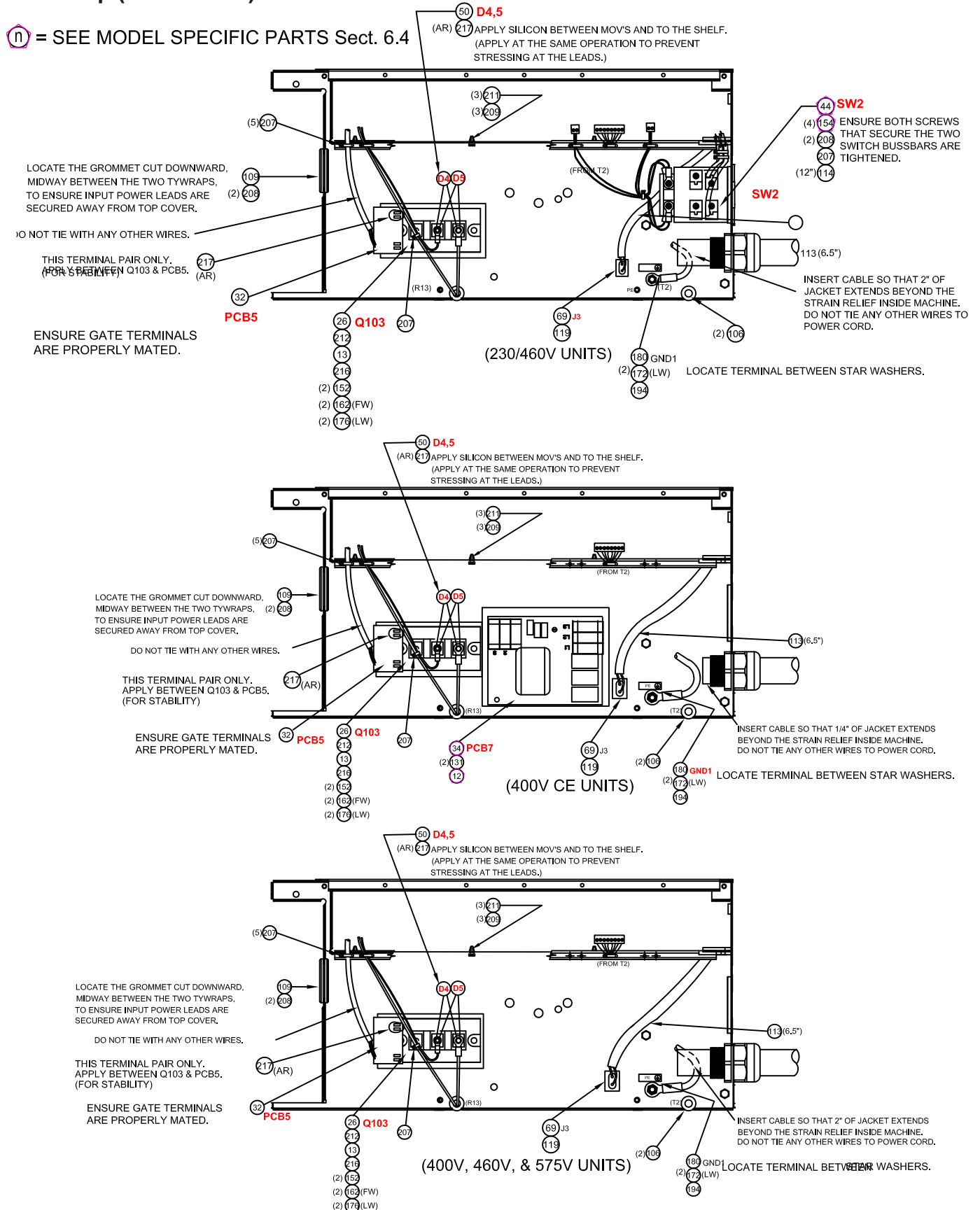

NOTE: ORIENT ALL TERMINALS AS SHOWN.

SECTION 6

REPLACEMENT PARTS

6.3 Top BOM

PC1600 REPLACEMENT PARTS				
ITEM	QTY	P/N	DESCRIPTION	SYMBOL
12	SEE SECT 6.4		INSULATOR SM EMC FILTER PCB Kyde	
13	1	0558008823	PLATE MOUNTING PILOT ARC IGBT	
26	1	0558007886	IGBT 50A 1200V	Q103
32	1	0558038344	PC BOARD - DRIVER PILOT ARC	PCB5
34	SEE SECT 6.4		PC BOARD - EMC FILTER 35A	PCB7
44	SEE SECT 6.4		SWITCH VOLTAGE SELECTOR	SW2
50	1	0558007895	KIT MOV 275VAC 140J	D4,5
69	1	0558001013	HOUSING UNIV CAP 2 POS - Wht	J3
106	5	97W34	GROMMET RUBBER 0.31ID 0.44GD .06W	
109	1	950167	GROMMET RUBBER 1.12ID 1.50GD .06W	
113	1.13'	90861726	TUBING PVC, 300V, #1 BLACK	
114	1.63'	99510498	TUBING PVC, 600V, 1/2" BLACK	
119	1	0558001014	SEAL WIRE UNIVERSAL HOUSING 2 POS	
131	AR	61387910	SCREW SQ PAN TRI #10-32 .38 w/ LW	
152	AR	61301912	SCREW PHL PAN #10-32 .75	
154	SEE SECT 6.4		SCREW SLT PAN TAP #10 .38	
162	AR	05W01055	WASHER FLAT M5	
172	AR	64307996	WASHER LOCK ET 1/4	
176	AR	05W10051	WASHER LOCK M5	
180	AR	63300100	NUT 1/4-20	
194	1	2091558	LABEL PE GROUND	
207	AR	180W68	TYWRAP SM 4"	
208	AR	631507	TYWRAP MED 5.5"	
209	AR	180W66	TYWRAP LG 7.25"	
211	AR	99511578	BASE TYWRAP SNAP-IN .218MH	
212	1	951190	PAD THERMAL IGBT MODULE	
216	1	951191	PAD THERMAL MOUNTING PLATE PA IGBT	
217	AR	71200732	ADHESIVE SILICON RUBBER DOW 732 - Clear	

SECTION 6

REPLACEMENT PARTS

6.3 Left Inside (0558007540)

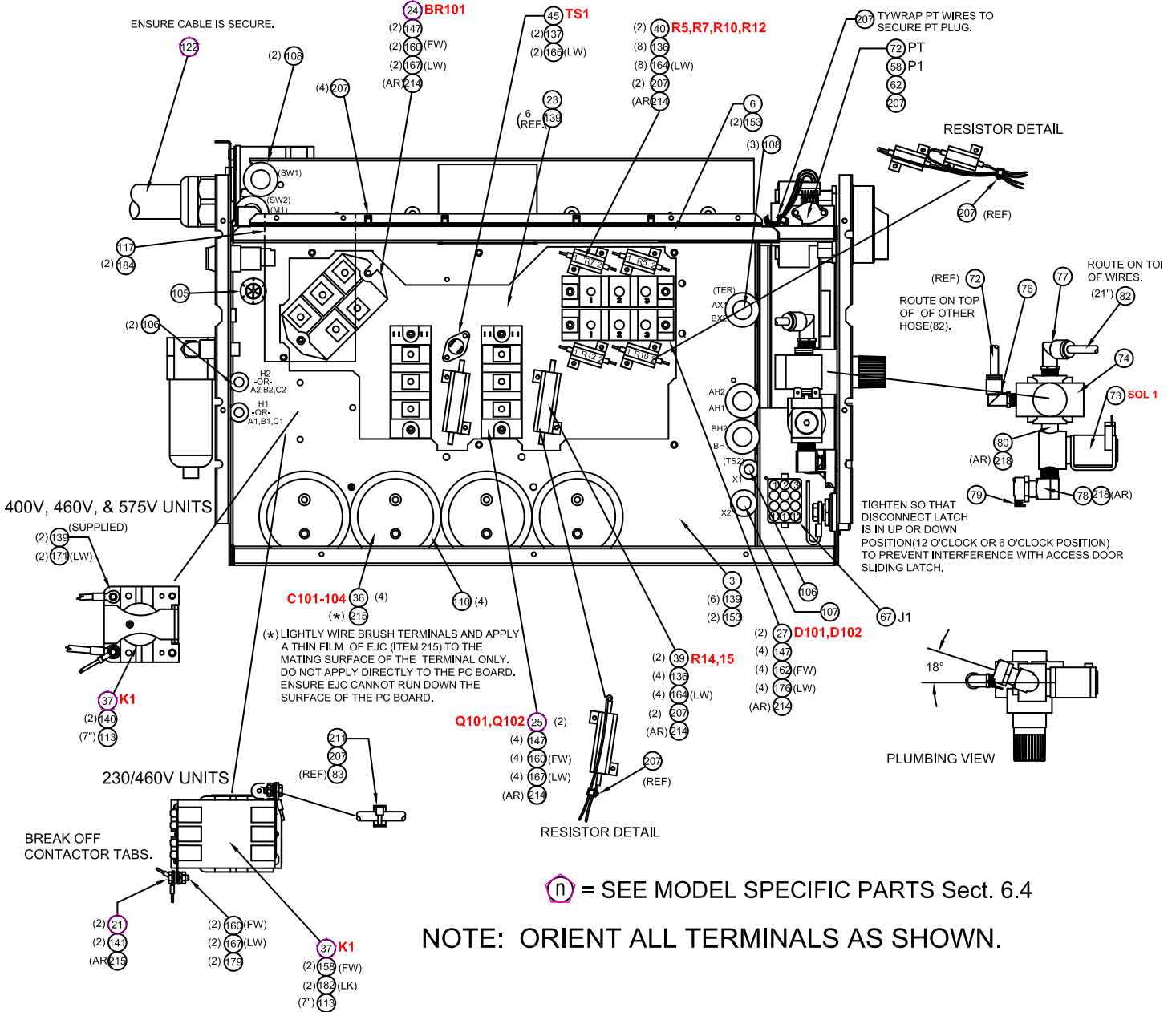

PC1600 REPLACEMENT PARTS				
ITEM	QTY	P/N	DESCRIPTION	SYMBOL
3	1	0558007200	BRACKET HEATSINK	
6	1	0558007888	BRACE SHELF	
21	SEE SECT 6.4		BUSSBAR 3PH CONTACTOR	
23	1	0558007154	HEATSINK (SCREEN TOOL 0558954072)	
24	SEE SECT 6.4		BRIDGE RECTIFIER 110A 1600V	BR101
25	SEE SECT 6.4		IGBT DUAL 150A 600V	Q101,102
27	2	951185	DIODE DUAL 100A 600V	D101,102
36	SEE SECT 6.4		CAPACITOR ALUM 4100uF 300VDC	C101-104
37	SEE SECT 6.4		RELAY SPST 24VAC 20A(110VDC) w/ MAG BLOWOUT	K1
39	2	17750851	RESISTOR 10 OHM 50W 3% w/ Leads	R14,15
40	2	0558008081	KIT RESISTOR PAIR 20 OHM 25W 1% w/Leads	R5,7,R10,12

SECTION 6

REPLACEMENT PARTS

6.3 Left Inside BOM

45	1	951085	SWITCH THERMAL N/C 176°F	TS1
58	1	0558003430	CONNECTOR IDC 6 PIN 22awg - Red	PT P1
62	1	0558003429	COVER IDC CONNECTOR 6 PIN	
67	1	951109	HOUSING UNIV CAP 12 POS - Wht	J1
72	1	0558008354	KIT TRANSDUCER PRESSURE 2-100 PSI w/ HOSE	PT
73	1	0558007072	VALVE SOLENOID 3-WAY 75 PSID 24VAC	SOL1
74	1	0558007071	REGULATOR PRESSURE 7-125 PSI	
76	1	0558007075	ELBOW 90° 1/4 OD TUBE 1/8NPTM	
77	2	0558004184	ELBOW 90° 5/16 OD TUBE 1/4NPTM	
78	2	0558006292	ELBOW STREET 90° 1/4NPT	
79	1	0558005635	COUPLING BODY QD 1/4NPTM	
80	1	67101075	NIPPLE 1/4NPT 7/8"LG	
82	1	0558008083	KIT HOSE POLYURETHANE 3/16 ID 5/16 OD Red (21")	
83	-	-	-	
105	1	0558007073	GROMMET RUBBER (0.12-0.31) ID 0.50GD .06W	
106	5	97W34	GROMMET RUBBER 0.31ID 0.44GD .06W	
107	1	993837	GROMMET RUBBER 0.44ID 0.56GD .06W	
108	6	92W57	GROMMET RUBBER 0.63ID 0.88GD .06W	
110	8	0558007070	GROMMET RUBBER 2.50ID 2.75GD .06W	
113	1.13'	90861726	TUBING PVC, 300V, #1 BLACK	
117	1	0558008065	SHEET INSULATING (6.25" 3") None	
122		SEE SECT 6.4	POWER CORD 6awg 4 Conductor	
136		61325826	SCREW SQ PAN TRI #4-40 .38	
137	AR	61325849	SCREW SQ PAN TRI #6-32 .25	
139	AR	61325878	SCREW SQ PAN TRI #8-32 .38	
140	AR	61325881	SCREW SQ PAN TRI #8-32 .63	
141	AR	61325902	SCREW SQ PAN TRI #10-24 .50	
147	AR	61308903	SCREW PHL PAN #10-24 .625	
153	AR	61327747	SCREW HE WSH TAP #8 .4 RIBBED	
158	AR	64304860	WASHER FLAT #6	
160	AR	64304050	WASHER FLAT #10	
162	AR	05W01055	WASHER FLAT M5	
164	AR	64302837	WASHER LOCK #4	
165	AR	64302860	WASHER LOCK #6	
167	AR	64302920	WASHER LOCK #10	
171	AR	64307887	WASHER LOCK ET #8	
176	AR	05W10051	WASHER LOCK M5	
179	AR	63300916	NUT #10-24	
182	AR	63610862	NUT LOCK NYLON SST #6-32	
184	AR	99510492	RIVET 1/8 (.032-.125)	
207	AR	180W68	TYWRAP SM 4"	
211	AR	99511578	BASE TYWRAP SNAP-IN .218MH	
214	AR	73585976	COMPOUND HEATSINK DOW 340 - White	
215	AR	73585980	COMPOUND ELECTRICAL JOINT ALCOA #2	
218	AR	73585435	ADHESIVE THREADLOCKER LOCTITE 242 - Blue	

SECTION 6

REPLACEMENT PARTS

6.3 Left Inside2 (0558007540)

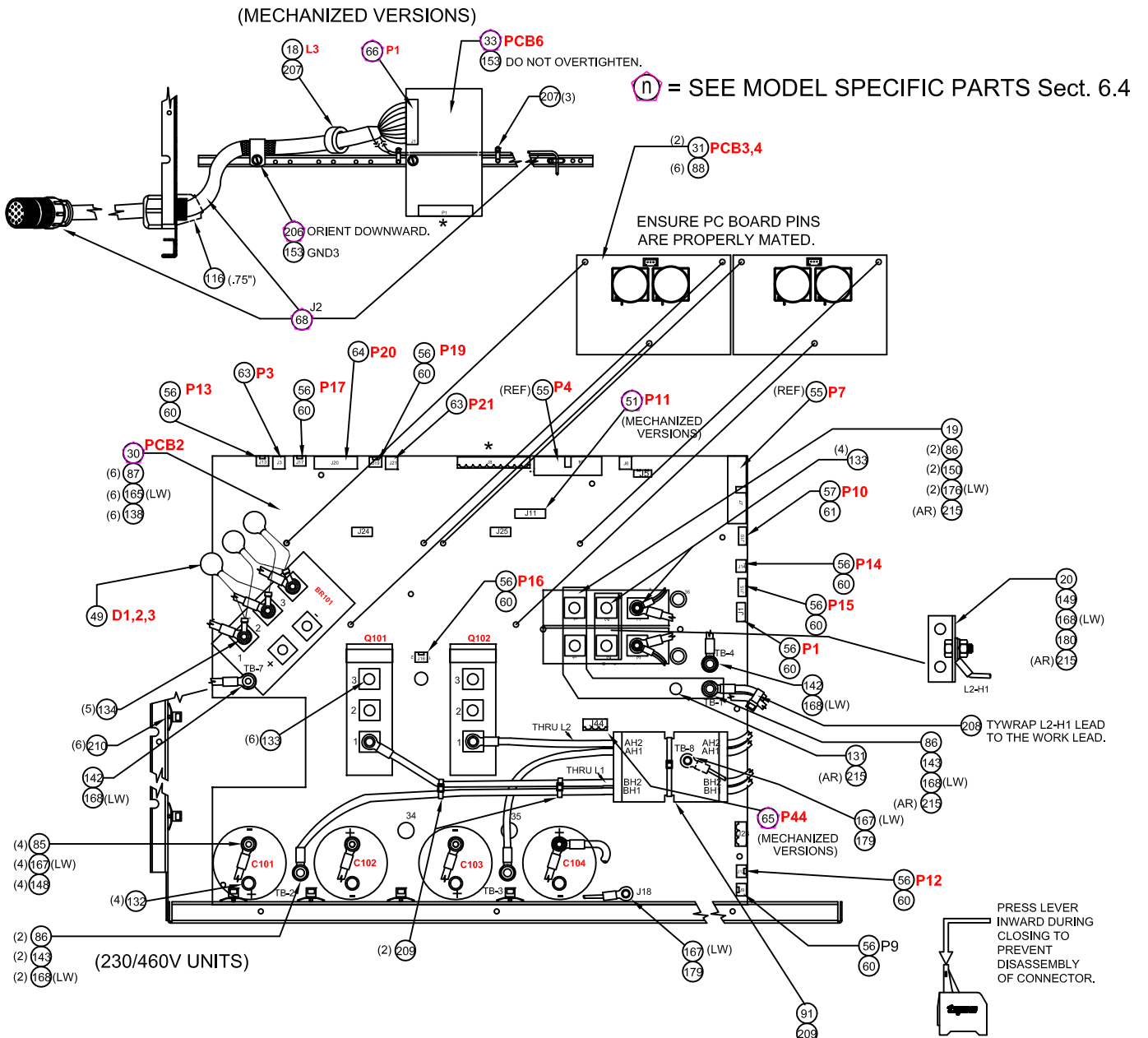

NOTE:
ORIENT ALL TERMINALS AS SHOWN.

SECTION 6

REPLACEMENT PARTS

6.3 Left Inside2 BOM

PC1600 REPLACEMENT PARTS				
ITEM	QTY	P/N	DESCRIPTION	SYMBOL
18	-	952002	TOROIDAL CORE	L3
19	1	0558007180	BUSSBAR DIODE (+)	
20	1	0558007181	BUSSBAR DIODE (-)	
29	1	0558038317	PC BOARD - CONTROL / DISPLAY	PCB1
30	SEE SECT 6.4		PC BOARD - POWER 90 AMP - 230/460, 400V	PCB2
31	2	0558038335	PC BOARD - DRIVER POWER	PCB3,4
33	SEE SECT 6.4		PC BOARD - REMOTE	PCB6
49	1	0558007738	KIT MOV 625VAC 230J	D1,2,3
51	SEE SECT 6.4		KIT JUMPER - MECHANIZED LOGIC	P11
55	2	0558007217	ASSY RIBBON CABLE 24 PIN 12"	P1/P4 , P2/P7
56	8	952064	CONNECTOR IDC 2 PIN 20awg - Yel	P9,12-17,19
57	1	952067	CONNECTOR IDC 3 PIN 20awg - Yel	P10
60	8	952065	COVER IDC CONNECTOR 2 PIN	
61	1	952068	COVER IDC CONNECTOR 3 PIN	
63	3	0558007184	CONNECTOR MINI-COMBICON 2 PIN	P1,3,21
64	1	0558007185	CONNECTOR MINI-COMBICON 8 PIN	P20
65	SEE SECT 6.4		CONNECTOR COMBICON 3 PIN	P44
66			CONNECTOR COMBICON 10 PIN	P1
68			RECEPTACLE / CABLE ASSY 14 PIN	J2
85	4	0558007160	SPACER ALUM #10 ID 1.0" LG	
86	5	0558007159	SPACER ALUM 1/4 ID 7/16" LG	
87	6	0558007158	STANDOFF ALUM FEMALE #6-32 HE 1-1/8" LG	
88	6	0558007078	STANDOFF PLASTIC PCB 7/8" LG	
91	1	0558007891	SPACER CABLE BUNDLE	
116	.33'	90863100	HEATSHRINK 1" BLACK	
131	AR	61387910	SCREW SQ PAN TRI #10-32 .38 w/ LW	
132	AR	0558006557	SCREW PHL HE #10-32 .50 w/ FLW Blk	
133	10	0558002087	SCREW PHL HE w/ FLW M5 12	
134	5	0558006737	SCREW PHL HE w/ FLW M6 12	
138	AR	61325851	SCREW SQ PAN TRI #6-32 .38	
142	AR	61325087	SCREW SQ PAN TRI 1/4-20 .50	
143	AR	61325090	SCREW SQ PAN TRI 1/4-20 1.00	
148	4	61308904	SCREW PHL PAN SST #10-32 1.50	
149	AR	61341087	SCREW HE CAP 1/4-20 .50	
150	AR	05S12025	SCREW SKT HE M5 25 Blk	
153	AR	61327747	SCREW HE WSH TAP #8 .4 RIBBED	
165	AR	64302860	WASHER LOCK #6	
167	AR	64302920	WASHER LOCK #10	
168	AR	64302996	WASHER LOCK 1/4	
176	AR	05W10051	WASHER LOCK M5	
179	AR	63300916	NUT #10-24	
180	AR	63300100	NUT 1/4-20	
206	SEE SECT 6.4		CLAMP CABLE STEEL .375 DIA	
207	AR	180W68	TYWRAP SM 4"	
208	AR	631507	TYWRAP MED 5.5"	
209	AR	180W66	TYWRAP LG 7.25"	
210	AR	950908	TYWRAP PUSH-IN LG 6.75"	
215	AR	73585980	COMPOUND ELECTRICAL JOINT ALCOA #2	

SECTION 6

REPLACEMENT PARTS

6.3 Rear View (0558007540)

Ⓝ = SEE MODEL SPECIFIC PARTS Sect. 6.4

(230/460V UNIT SHOWN)

(MECHANIZED VERSION SHOWN)

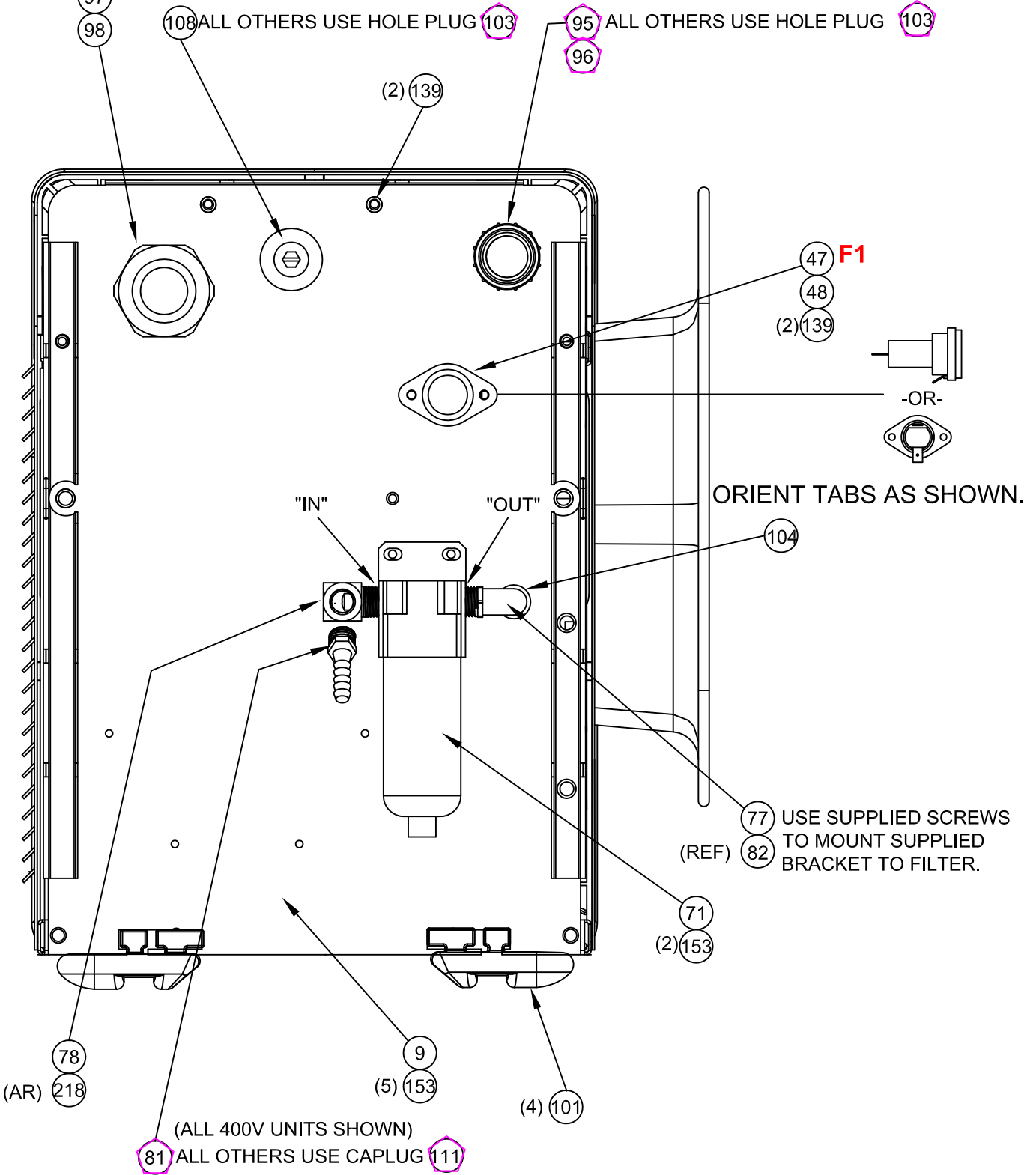

(END CAP / HANDLE REMOVED)

SECTION 6**REPLACEMENT PARTS****6.3 Rear View BOM**

PC1600 REPLACEMENT PARTS				
ITEM	QTY	P/N	DESCRIPTION	SYMBOL
9	1	0558007198M	PANEL REAR SILK SCREENED	
47	1	0558001379	FUSE MIDGET SLO-BLO 2A 600V	F1
48	1	952136	HOLDER FUSE	
71	1	0558007076	FILTER AIR	
77	2	0558004184	ELBOW 90° 5/16 OD TUBE 1/4NPTM	
78	2	0558006292	ELBOW STREET 90° 1/4NPT	
81	SEE SECT 6.4		ADAPTOR 1/4NPTM 1/4 ID HOSE	
82	1	0558008083	KIT HOSE POLYURETHANE 3/16 ID 5/16 OD Red (21")	
95	SEE SECT 6.4		STRAIN RELIEF SEALED 1/2" ZINC	
96	SEE SECT 6.4		LOCKNUT CONDUIT 1/2"	
97	1	0558002581	STRAIN RELIEF SEALED 1" NYLON Black	
98	1	950435	LOCKNUT CONDUIT 1"	
101	4	0558008603	FOOT RUBBER	
103	SEE SECT 6.4		PLUG HOLE .875 DIA	
104	1	647270	BUSHING SNAP .31ID .44MH	
108	6	92W57	GROMMET RUBBER 0.63ID 0.88GD .06W	
111	SEE SECT 6.4		CLOSURE TAPERED CAPLUG #4	
139	AR	61325878	SCREW SQ PAN TRI #8-32 .38	
153	AR	61327747	SCREW HE WSH TAP #8 .4 RIBBED	
218	AR	73585435	ADHESIVE THREADLOCKER LOCTITE 242 - Blue	

SECTION 6

REPLACEMENT PARTS

6.3 Front/Rear Isometric Views (0558007540)

n = SEE MODEL SPECIFIC PARTS Sect. 6.4

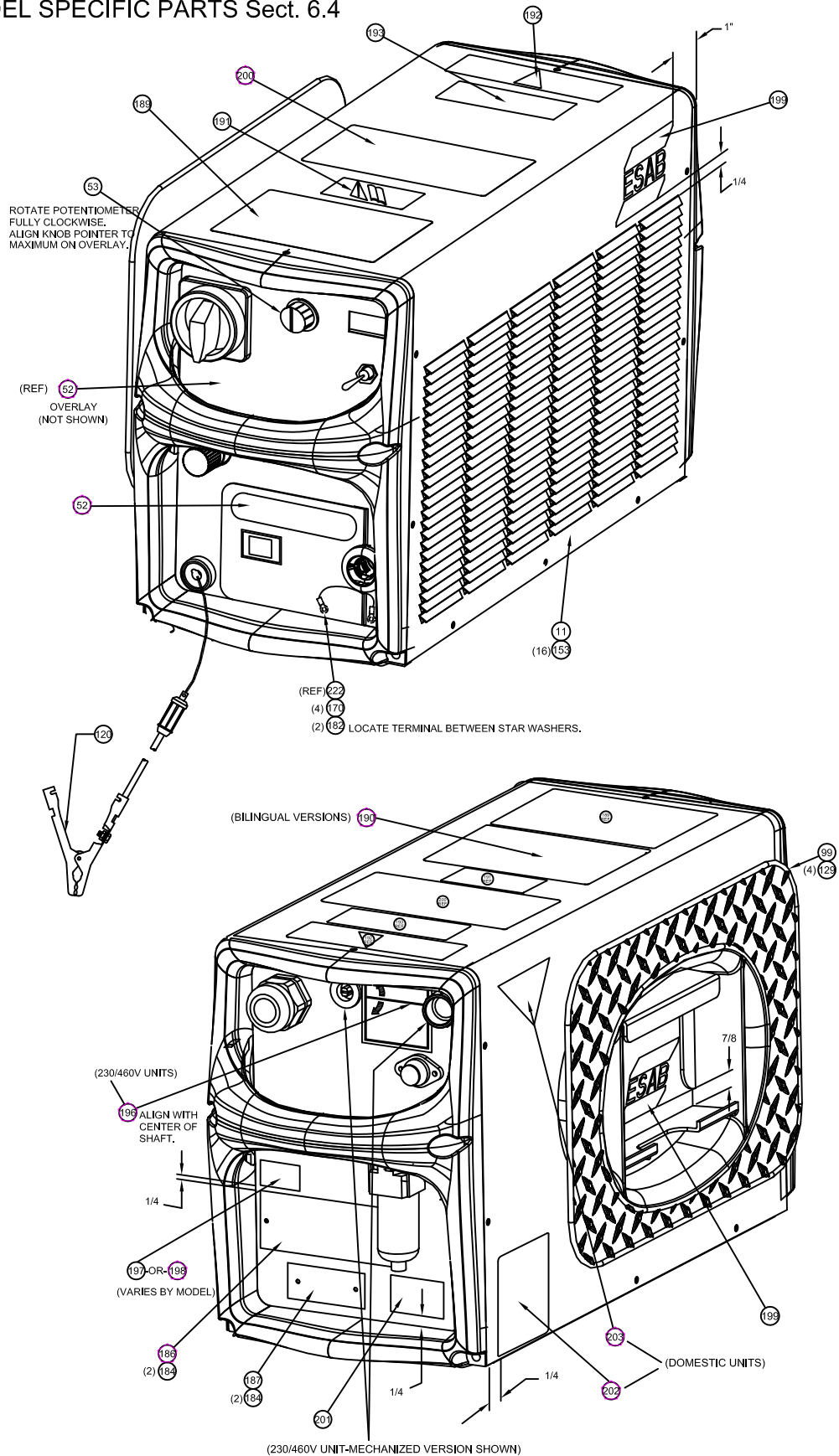

SECTION 6

REPLACEMENT PARTS

6.3 Front/Rear Isometric Views BOM

PC1600 REPLACEMENT PARTS				
ITEM	QTY	P/N	DESCRIPTION	SYMBOL
11	1	0558007199Y	COVER TOP	
52	SEE SECT 6.4		OVERLAY Bilingual Codes	
53	1	0558001818	KNOB 1-3/8" DIA	
99	1	0558006909	TORCH WRAP	
120				
129	4	0558007215	NUT ACORN CAP NYLON 1/4-20 - Black	
153	AR	61327747	SCREW HE WSH TAP #8 .4 RIBBED	
170	AR	64307860	WASHER LOCK ET #6	
182	AR	63610862	NUT LOCK NYLON SST #6-32	
184	AR	99510492	RIVET 1/8 (.032-.125)	
186	SEE SECT 6.4		LABEL RATING 208/230/460V PC-1300	
187	1	13730763	LABEL NAMEPLATE Stock / Serial No	
189	1	2091514	LABEL WARNING GENERAL ARC WELD & CUT	
190	SEE SECT 6.4		LABEL WARNING GENERAL ARC WELD & CUT French	
191	1	955269	LABEL SYMBOL CAUTION READ MANUAL	
192	1	954994	LABEL DANGER HIGH VOLTAGE Bilingual	
193	1	954707	LABEL WARNING OEM SAFETY INTERLOCK Bilingual	
196	SEE SECT 6.4		LABEL CAUTION VOLTAGE SELECT SWITCH Bilingual	
197	0	954425	LABEL CSA LR-30071 NRTL /C	
198	SEE SECT 6.4		LABEL CE - Trash Bin	
199	2	13734587	LABEL ESAB DIE CUT 4.5 2.6 Blk	
200	SEE SECT 6.4		LABEL CONSUMABLE BREAKDOWN PT-38 Bilingual	
201	1	0558954060	LABEL PATENT POWER SUPPLIES Bilingual	
202	SEE SECT 6.4		LABEL CUSTOMER ASSISTANCE	
203	SEE SECT 6.4		LABEL ISO 9001	
222	1	0558007206	WIRE KIT BASIC CONTROL	

SECTION 6

REPLACEMENT PARTS

6.4 Model Specific Parts BOM

0558007884 MECH 400V CE	0558007234 400V CE	0558007636 400V	0558007237 575V BL	0558008323 460V	0558007883 MECH 230/460V	0558007230F 230/460V BL	0558007230 230/460V	ITEM #	Part #	Description	Symbol
1	1							12	0558008672	INSULATOR SM EMC FILTER PCB Kydex	
					1	1	1	14	0558007151	INDUCTOR INPUT	L1
		1	1	1					0558007149	REACTOR LINE 3 PHASE 22A	
1	1								0558008732	REACTOR LINE CE 3 PHASE 22A	
				1	1	1	1	16	0558007189	XFMR MAIN 230/460V	T1
			1						0558007191	XFMR MAIN 575V	
1	1	1							0558007190	XFMR MAIN 400V	
1	1	1		1	1	1	1	17	0558007188	XFMR CONTROL 208/230/400/460V	T2
			1						0558008546	XFMR CONTROL 230/575V	
					2	2	2	21	0558007527	BUSSBAR 3PH CONTACTOR	
1	1	1	1	1				24	0558007068	BRIDGE RECTIFIER 110A 1600V	BR101
					1	1	1		0558007077	BRIDGE RECTIFIER 160A 1600V	
								25	0558006151	IGBT DUAL 150A 600V	Q101,102
2	2	2		2	2	2	2		0558008052	IGBT DUAL 200A 600V	
			2						0558005462	IGBT DUAL 150A 1200V	
1	1	1		1	1	1	1	30	0558038323	PC BOARD - POWER 90 AMP - 230/460, 400V USE Dwg# 0558038315	PCB2
			1						0558038347	PC BOARD - POWER 90 AMP - 575V USE Dwg# 0558038315	
1								33	0558038337	PC BOARD - REMOTE	PCB6
1	1							34	455803880	PC BOARD - EMC FILTER 35A	PCB7
4	4	4	4	4				36	0558007161	CAPACITOR ALUM 4100uF 300VDC	C101-104
					4	4	4		0558007162	CAPACITOR ALUM 5400uF 300VDC	
1	1	1	1	1				37	0558002576	RELAY SPST 24VAC 20A(110VDC) w/ MAG BLOWOUT	K1
					1	1	1		950247	CONTACTOR 3P 40A 24VAC	

SECTION 6

REPLACEMENT PARTS

6.4 Model Specific Parts BOM

0558007884 MECH 400V CE	0558007234 400V CE	0558007636 400V	0558007237 575V BL	0558008323 460V	0558007883 MECH 230/460V	0558007230F 230/460V BL	0558007230 230/460V	ITEM #	Part #	Description	Symbol
					1	1	1	44	0558007183	SWITCH VOLTAGE SELECTOR	SW2
1					1			51	0558008111	KIT JUMPER - MECHANIZED LOGIC	P11
			1	1	1	1	1	52	0558954069	OVERLAY Bilingual Codes	
1	1	1							0558954070	OVERLAY Plain	
1					1			65	951005	CONNECTOR COMBICON 3 PIN	P44
1					1			66	951016	CONNECTOR COMBICON 10 PIN	P1
1					1			68	0558007890	RECEPTACLE / CABLE ASSY 14 PIN	J2
1	1	1						81	30354	ADAPTOR 1/4NPTM 1/4 ID HOSE	
1					1			95	526652	STRAIN RELIEF SEALED 1/2" ZINC	
1					1			96	2062151	LOCKNUT CONDUIT 1/2"	
1	2	2	2	2		1	1	103	23610197	PLUG HOLE .875 DIA	
			1	1	1	1	1	111	60909075	CLOSURE TAPERED CAPLUG #4	
					1	1	1	122	0558007192	POWER CORD 6awg 4 Conductor	
		1	1	1					0558007193	POWER CORD 10awg 4 Conductor	
1	1								0558007194	POWER CORD CE 6mm 4 Conductor	
2	2	2		2	2	2	2	124	634736	TERM, WIRE JOINT INS, 18-16 AWG	
					4	4	4	154	61326903	SCREW SLT PAN TAP #10 x .38	
					1	1	1	186	0558954073	LABEL RATING 208/230/460V PC-1600	
				1					0558954152	LABEL RATING 460V PC-1600	
			1						0558954074	LABEL RATING 575V PC-1600	
		1							0558954075	LABEL RATING 400V PC-1600	
1	1								0558954161	LABEL RATING 400V CE PC-1600	

SECTION 6

REPLACEMENT PARTS

6.4 Model Specific Parts BOM

0558007884 MECH 400V CE	0558007234 400V CE	0558007636 400V	0558007237 575V BL	0558008323 460V	0558007883 MECH 230/460V	0558007230F 230/460V BL	0558007230 230/460V	ITEM #	Part #	Description	Symbol
			1			1		190	0558954085	LABEL WARNING GENERAL ARC WELD & CUT French	
					1	1	1	196	0558954064	LABEL CAUTION VOLTAGE SELECT SWITCH Bilingual	
1	1							198	954565	LABEL CE - Trash Bin	
		1	1	1		1	1	200	0558954090	LABEL CONSUMABLE BREAKDOWN PT-38 Bilingual	
	1								0558954137	LABEL CONSUMABLE BREAKDOWN PT-38 CE	
1					1				0558954159	LABEL CONSUMABLE BREAKDOWN PT-37 (90A)	
				1	1	1	1	202	0558954034	LABEL CUSTOMER ASSISTANCE	
				1	1	1	1	203	954506	LABEL ISO 9001	
1					1			206	2235784	CLAMP CABLE STEEL .375 DIA	
					1	1	1	223	0558007207	WIRE KIT VOLTAGE SELECTOR SWITCH	
					1	1	1	224	0558007208	WIRE KIT DUAL VOLTAGE POWER	
1	1	1	1	1				225	0558007209	WIRE KIT SINGLE VOLTAGE POWER	
1	1							226	0558007210	WIRE KIT CE 400V	

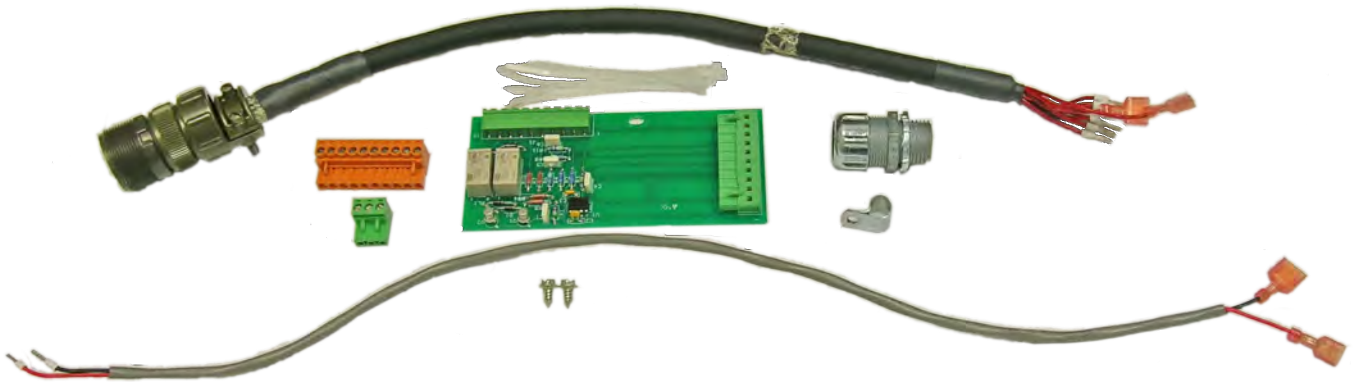
SECTION 7**MECHANIZED CONVERSION****7.0****MECHANIZED CONVERSION**

Item No.	Part No.	Qty	Description
1	0558038337	1	PC BOARD-REMOTE
2	0558007890	1	RECEPTACLE/CABLE ASSY 14 PIN
3	951016	1	CONNECTOR COMBICON 10 PIN
4	951005	1	CONNECTOR COMBICON 3 PIN
5	526652	1	STRAIN RELIEF SEALED 1/2 ZINC "
6	2062151	1	LOCKNUT CONDUIT 1/2 "
7	2235784	1	CLAMP CABLE STEEL .375 DIA.
8	61327747	2	SCREW SLT HEX TAP #8 X .38 SERRATED
9	180W68	8	TY-WRAP SM 4 "

1. Access the inside of the PC-1300/1. 1600 by unscrewing the screws and removing the cover.



2. Assemble the strain relief onto the 14 pin cable as shown and partially tighten.

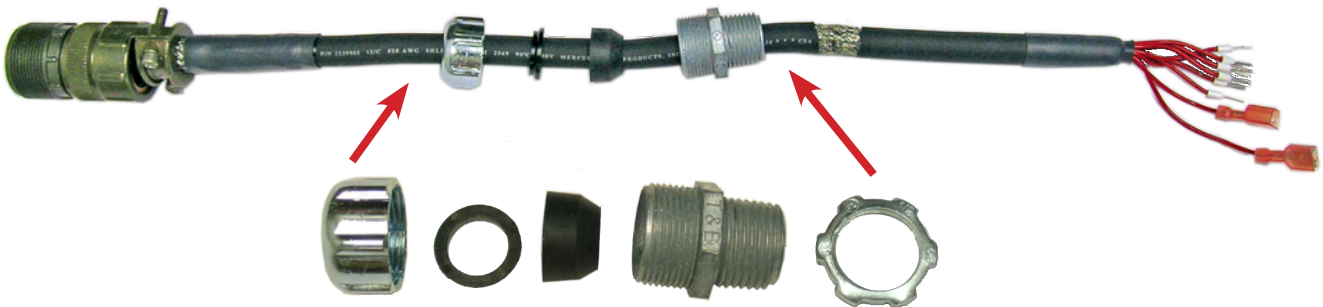

3. Remove the hole plug on the top right side of the back of the unit.

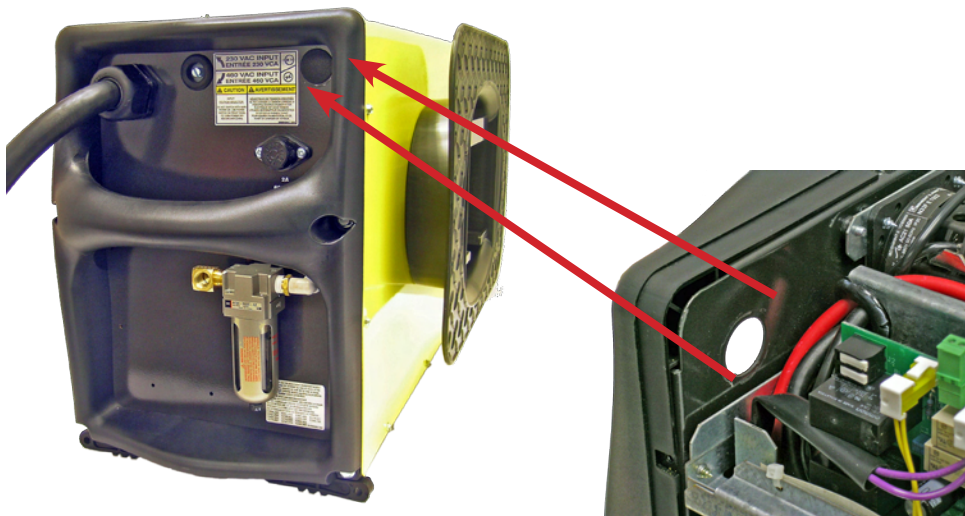

- 4. Cut the tie wraps, unplug control transformer wires to allow for easier cable routing (on a multi-voltage unit unplug voltage select switch wires also).

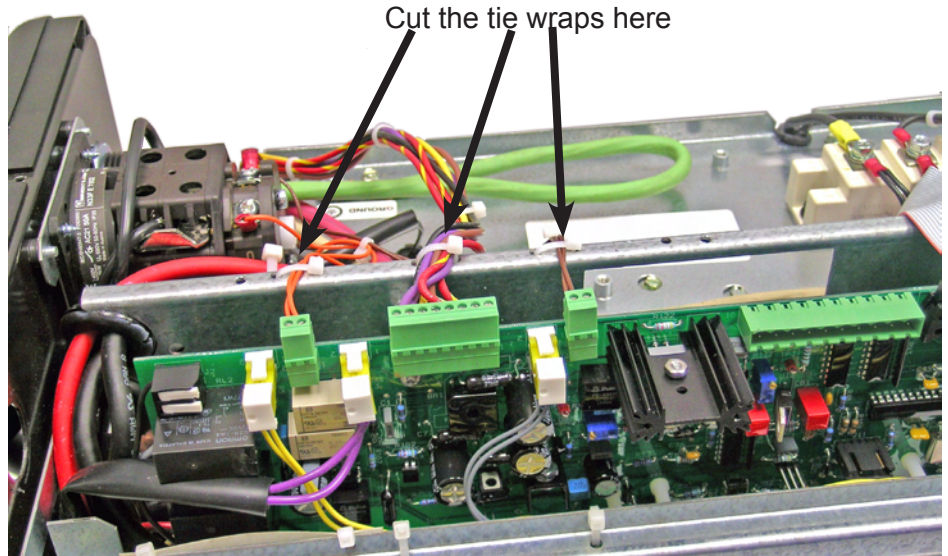

- 5. Thread the cable through the hole as shown and allow cable to hang loose. Add locknut and partially tighten.

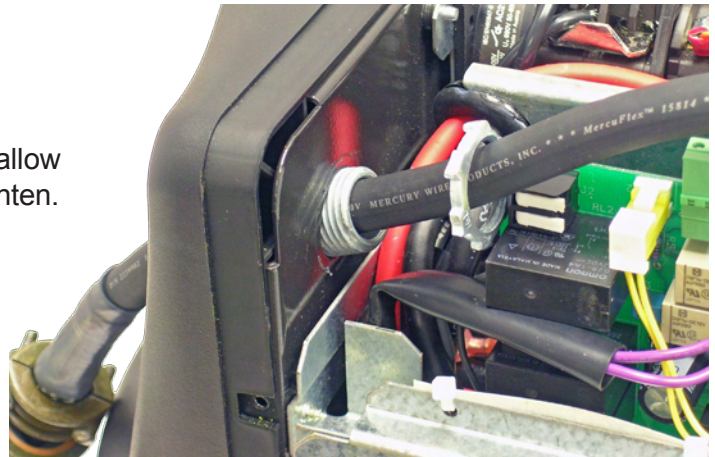

- 6. Assemble the cable clamp onto the exposed shield area and attach to the frame with the screw provided. Orient clamp downward as shown.

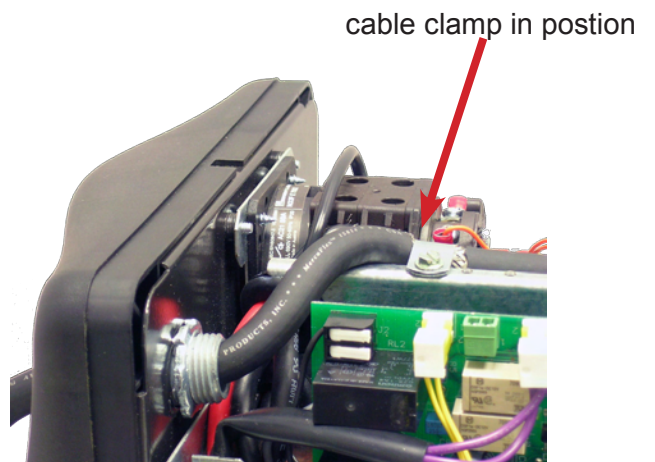
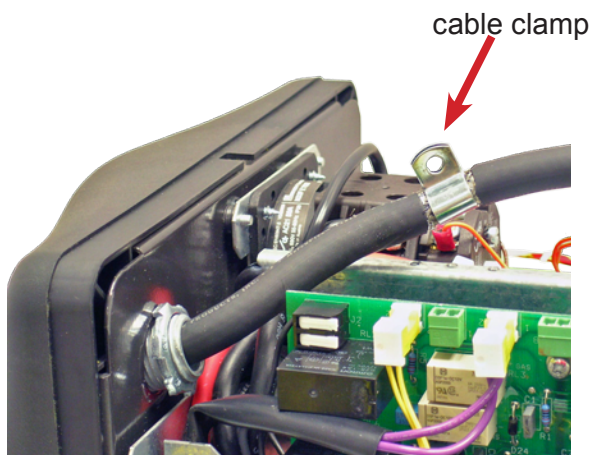

7. Tighten the strain relief nut from the inside first ..;.....

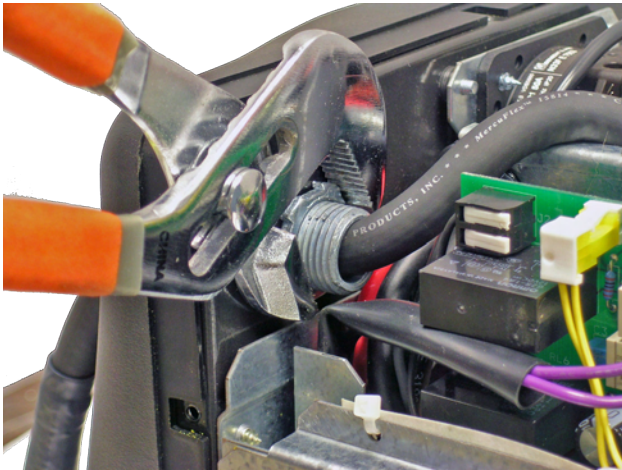

..... and then tighten the outside strain relief nut.



8. Align the 10-pin connector with the pc board header to identify which end of the connector is pin 1 and therefore ensure proper connections of the 9 cables wires.

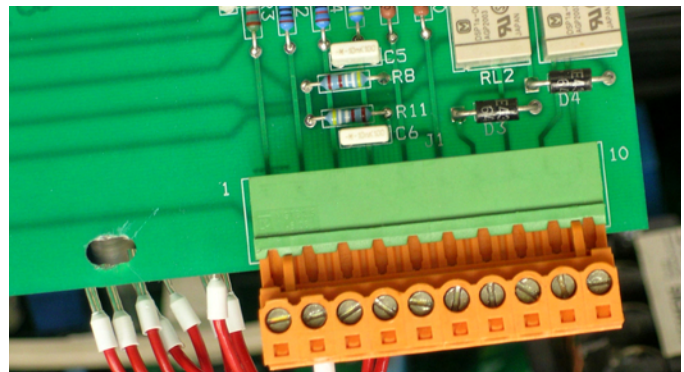

9. Install each wire and tighten. Cable wires are numbered 2 through 10 and must be connected in numerical sequence starting with number 2. The pc board has been stamped with numbers 1 and 10 to show the direction of sequence for the wires.

pin 1 is blank

each wire is numbered

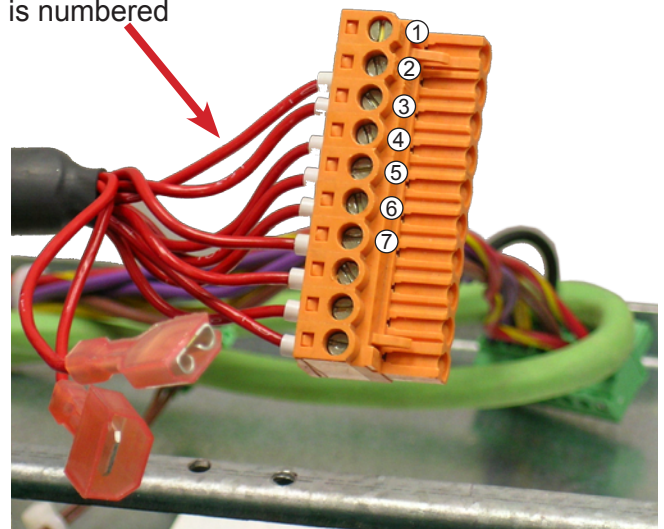

- 10. Connect the pc board to the main power control board as shown below. Secure the pc board to the frame with the screw provided.

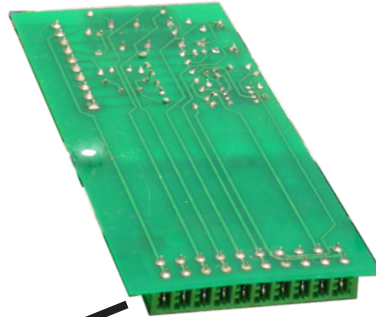
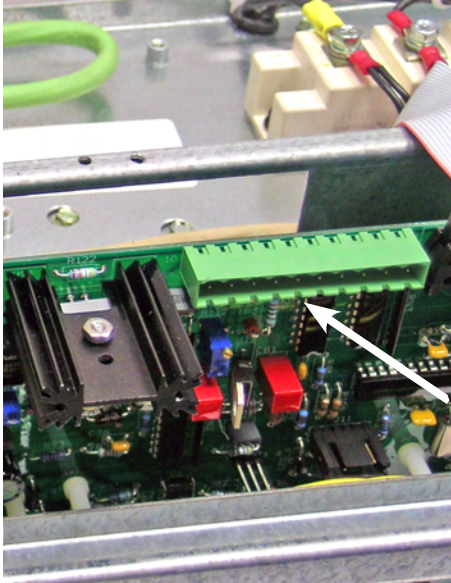

- 11. Connect the fast-on connectors of the "2-wire cable" to the 14 pin cable.

fast-on connectors

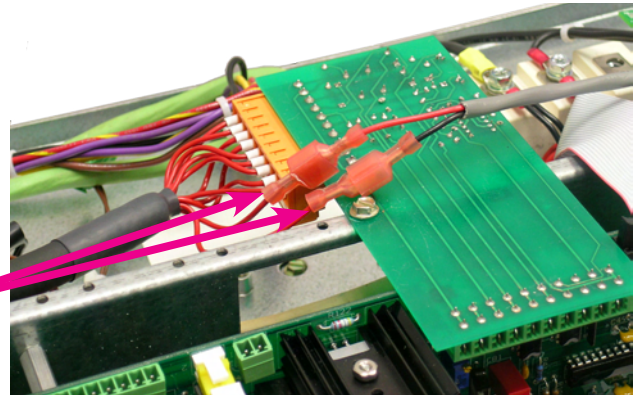

- 12. Route the "2-wire cable" under the pc board and tie wrap to the frame using the provided holes in the areas shown.

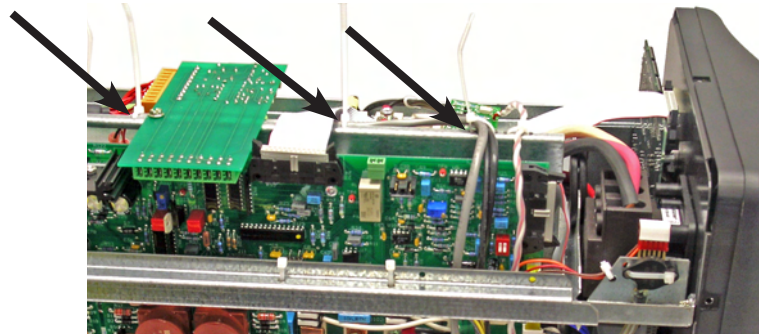

- 13. Re-install the plugs and tie wraps on the previously unplugged wires.

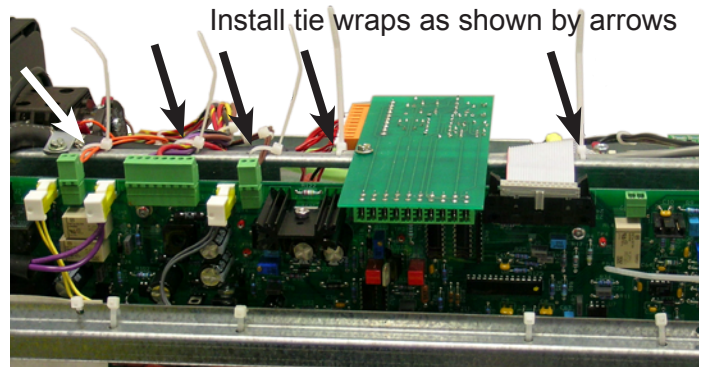

- 14. Route the "2-wire cable" downward behind the shelf brace.
- 15. Locate the 3-pin connector on the existing main power control board

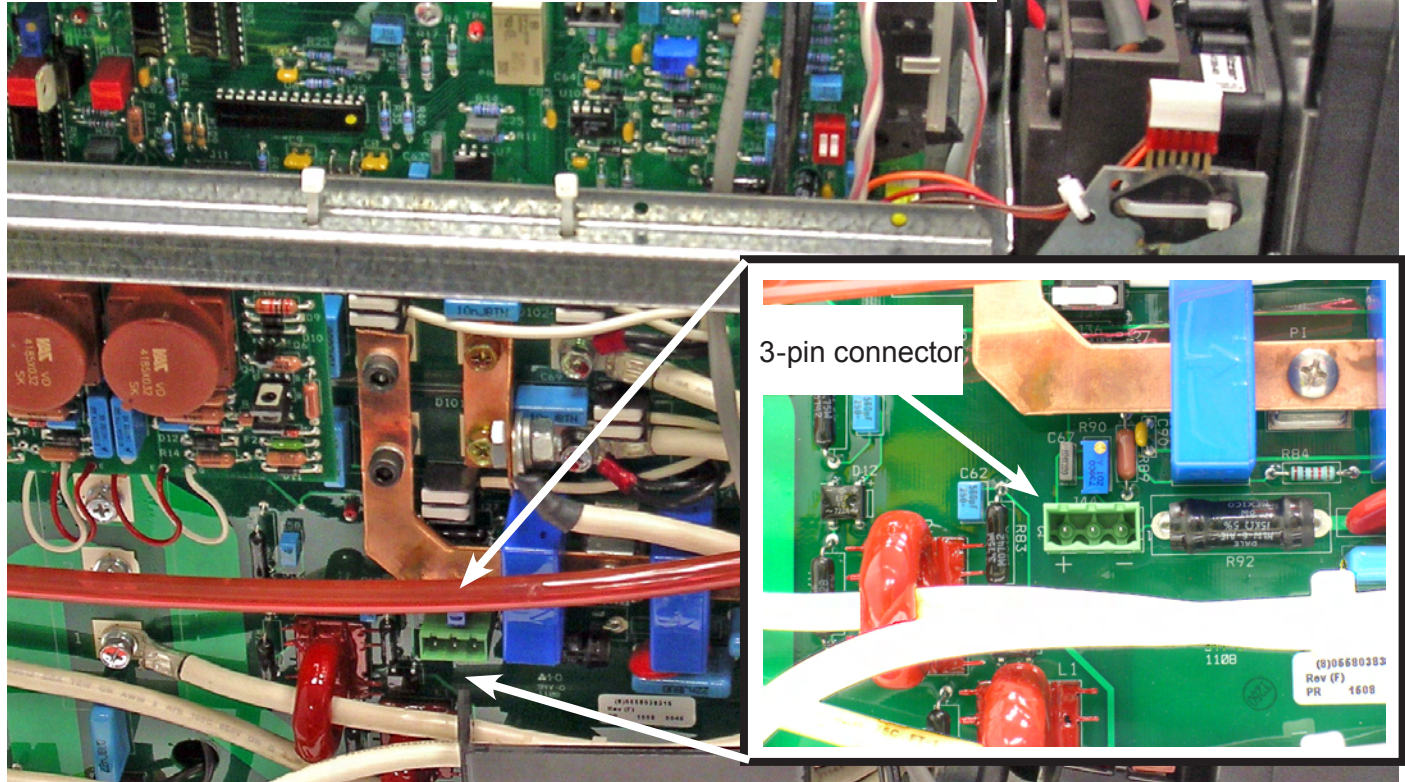

- 16. Align the 3-pin connector with the pc board header to identify which end of the connector aligns with the "+" and "-" on the pc board. On the connector, insert the red wire to the "+" and black wire to the "-" from the "2-wire cable" as shown and tighten.

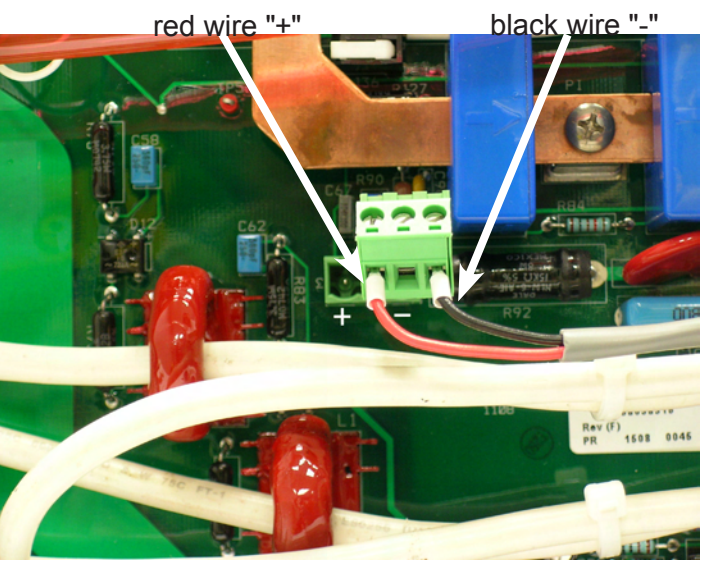

- 17. Plug in the 3-pin connector on the pc board.

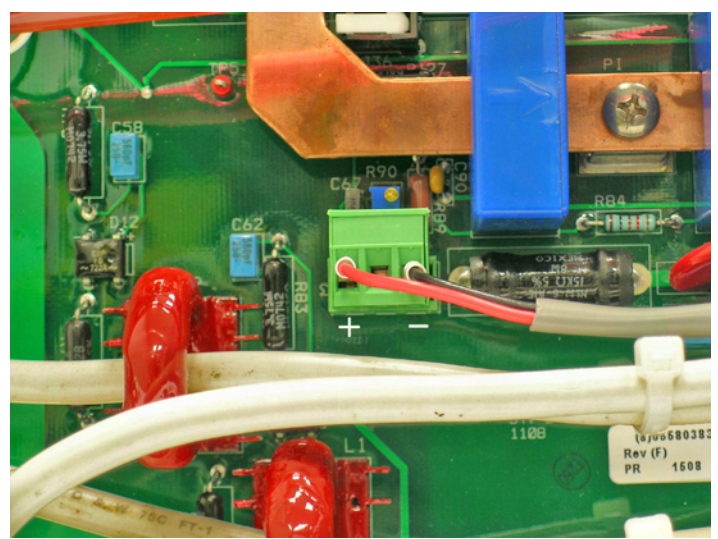

18. Secure the cable with tie wraps as shown by arrows. Do not tie any wires with the nearby twisted pair.

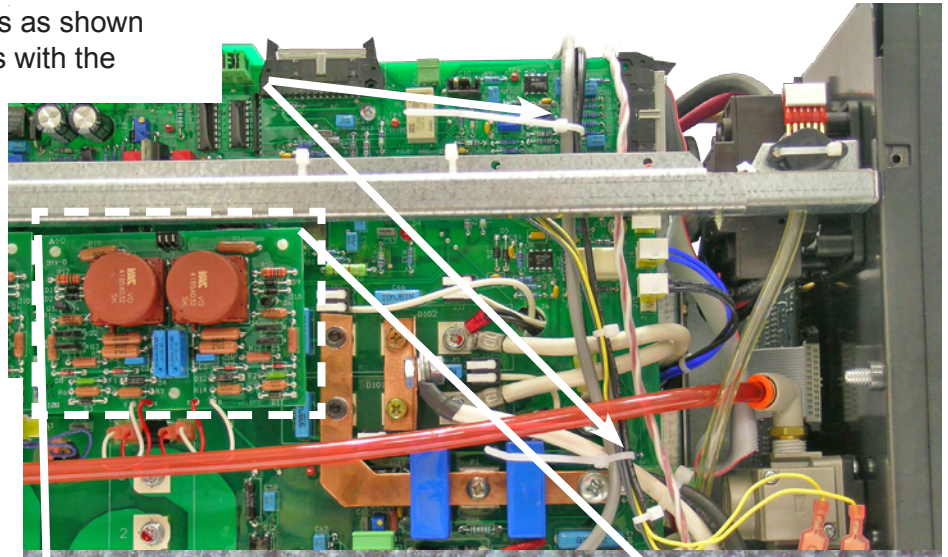

19. Plug 5-pin jumper into J11 header. This can be done by either inserting the jumper from above or by removing the driver pc board. Removing the driver pc board will allow easier access. Ensure board is reinstalled properly by aligning three long header pins and fully snapping board into place on mounting pillars. Installing this plug will change the Trigger Lock switch on the front panel for mechanized logic. Refer to the mechanized section of the machine instruction manual.

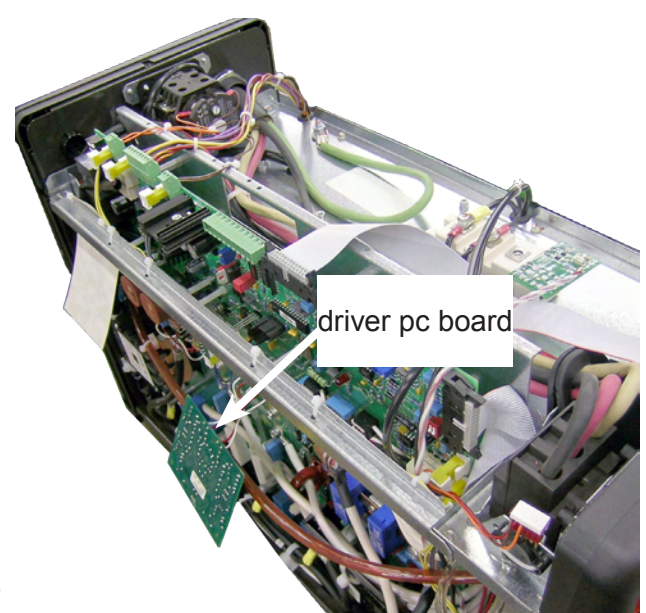
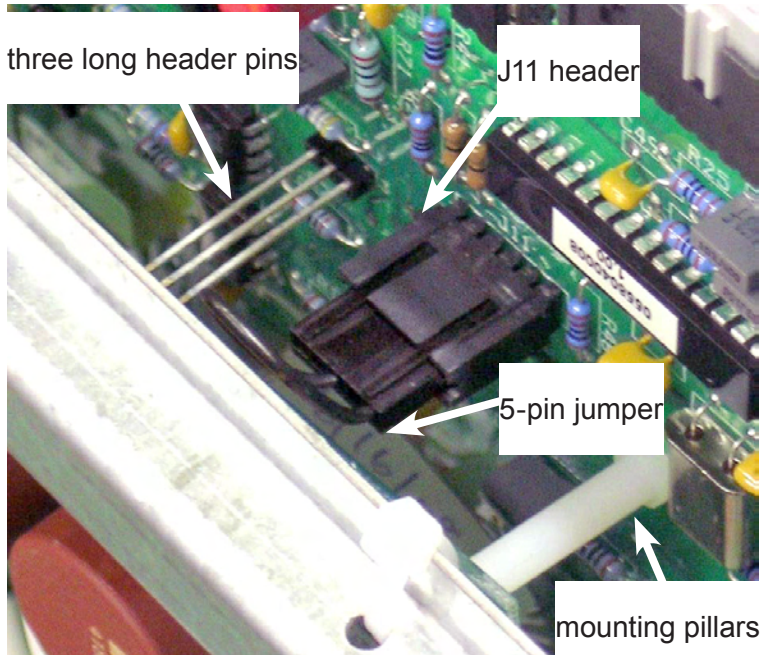
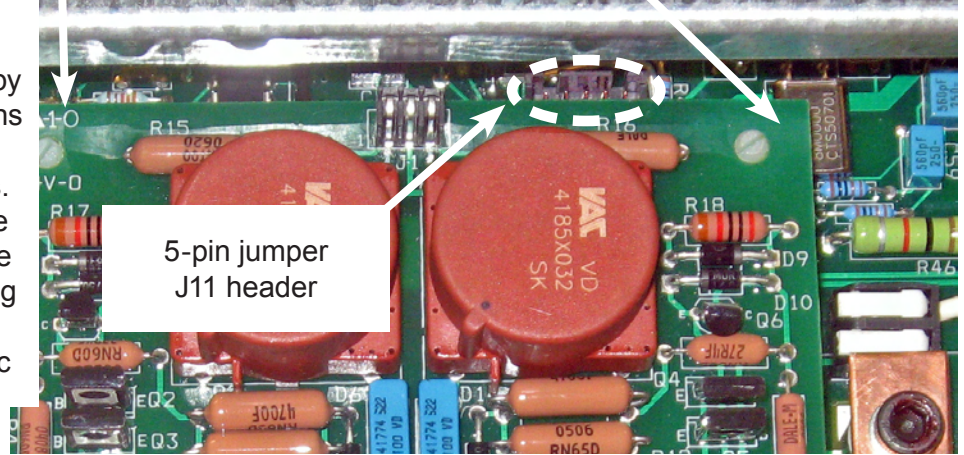

20. Trim all tie wraps and replace the unit's cover.

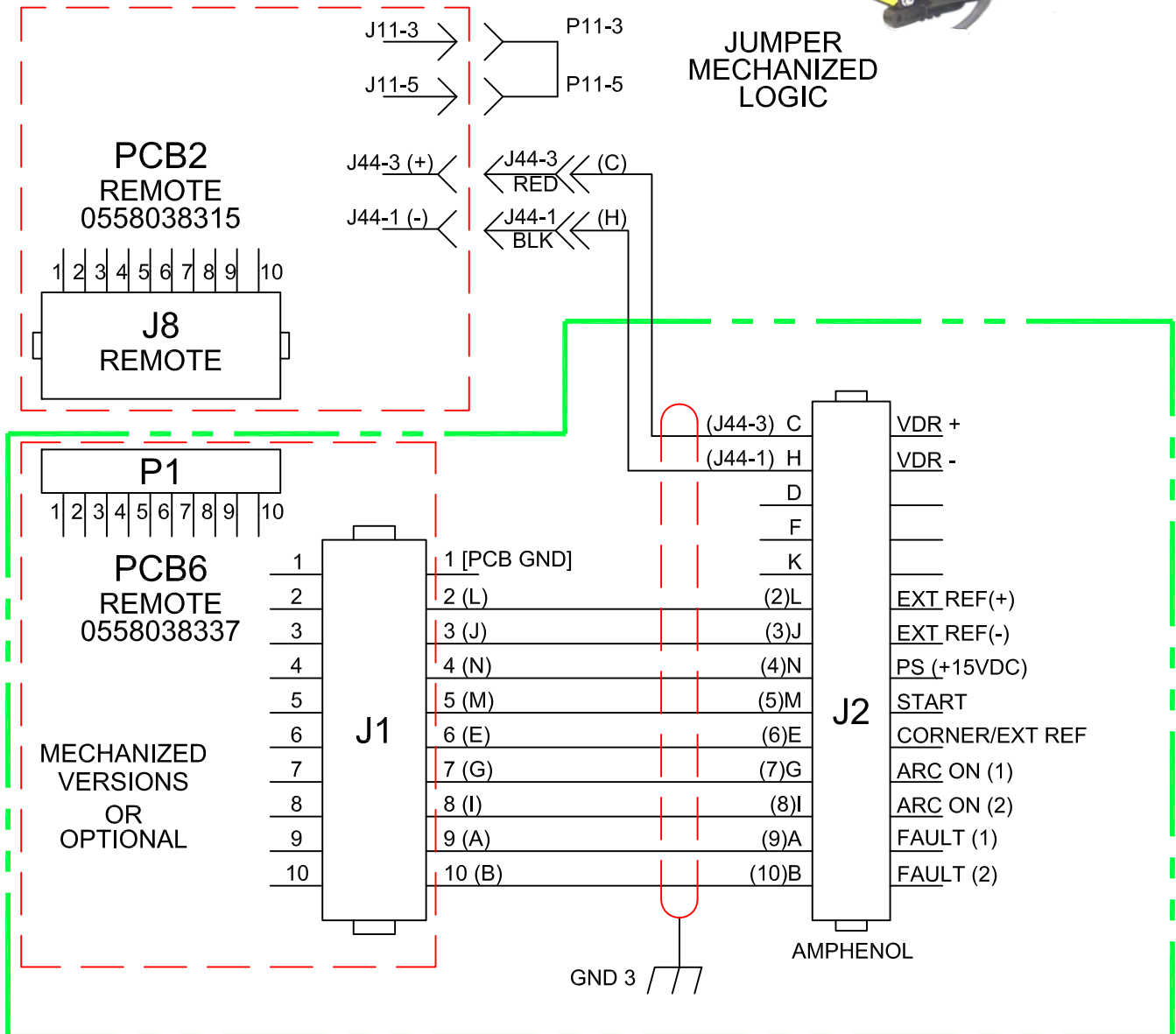



Error 13

Possible cause: E13 says that the machine failed the PIP test because no current was detected. Check the following

- 1- Consumables, anything that would prevent the electrode from touching the nozzle
- 2- Open torch leads, check power cable and pilot arc leads
- 3- Tertiary winding, check connections and wires at J14 and J15.

- 1. Turn off power.
- 2. Remove cover.
- 3. Locate SW1 DIP Switch on PCB1.

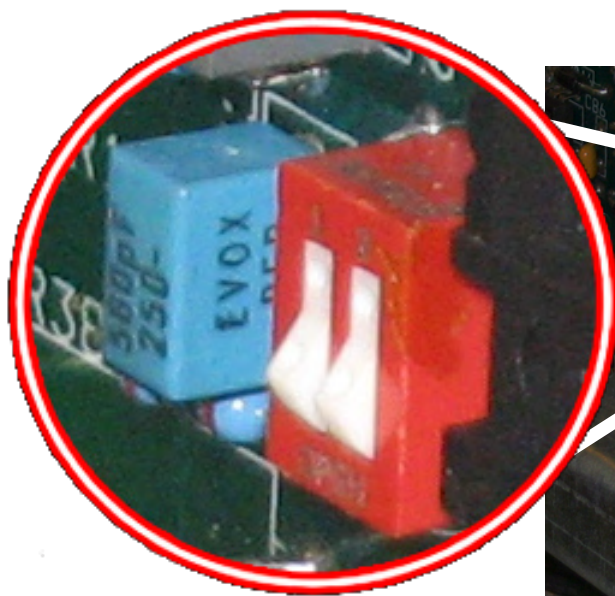

SW1 default state

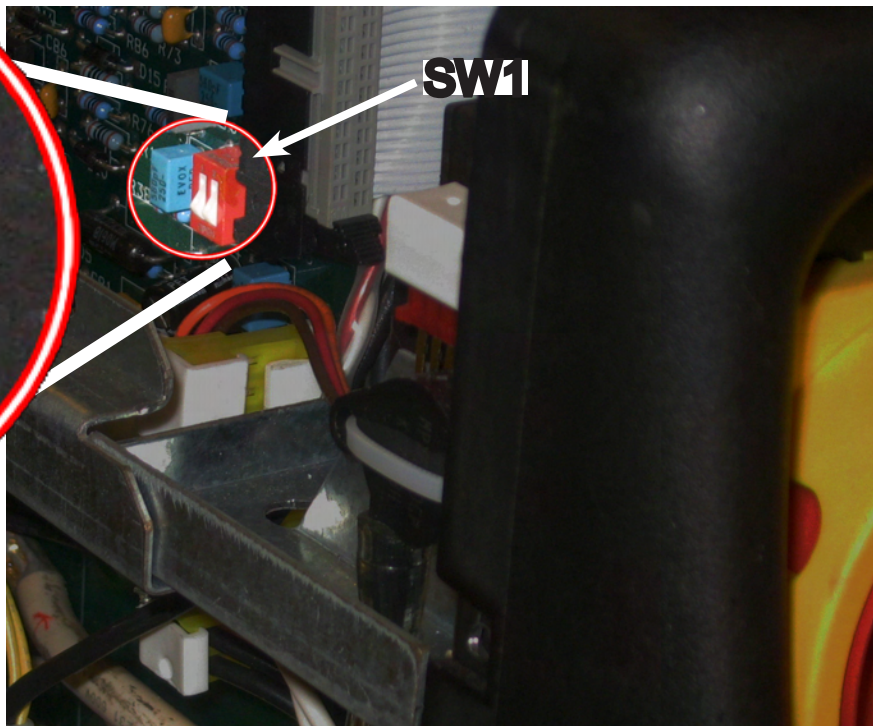

8.0 Error 13

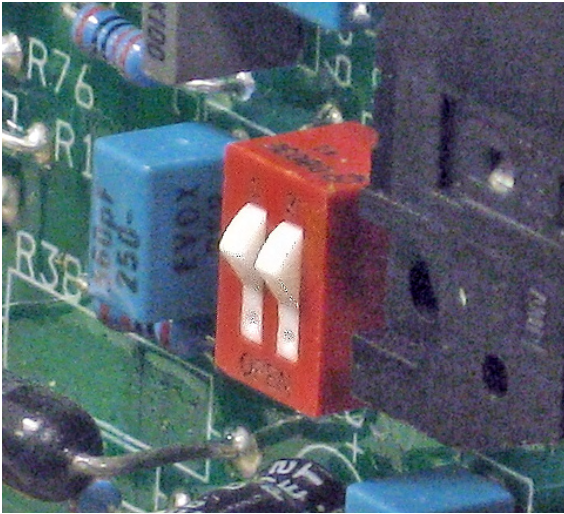

SW1 opposite state

4. Toggle SW1 to opposite state.



5. Turn on power. LED Display will read "RST" (Reset).
6. Turn off power.

7. Toggle SW1 to default state, replace cover and resume operations.

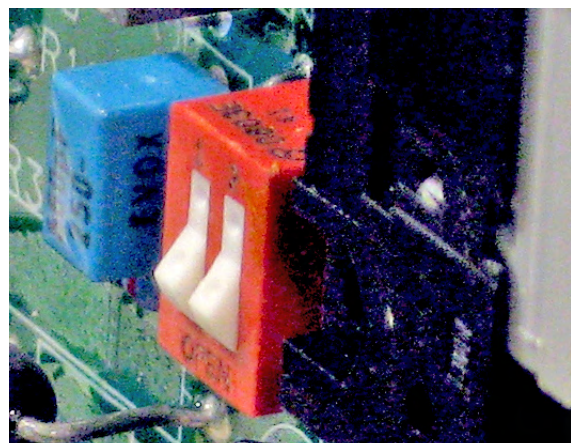

8.1 Error 15**Error 15**

Possible cause: E15 says that the machine failed to get voltage buildup on the Buss Capacitors C101,C102,C103, and C104.

1- Check input power

2- Check input bridge output

3- Check "pre-charge circuit" on power board. If the power board has just been replaced check position of J15, try position 1 and 2 first, if error 15.

Err 15 must be reset internally in Program version 1, 1.01 and 1.02. With version 1.03, it is reset by powering down and powering up the PC1600

Program changes:

Program	Rev #	Date	Change
1	OR	7-Dec-07	Original Release
1.01	A	11-Jul-08	Requirement for ability to program amperage level setting of machine via the power pcb at machine factory final test.
1.02	B	18-Aug-08	Corrected "Machine randomly fails to error condition 13 if power is applied to machine prior to shop air being supplied to machine.
1.03	C	9-Oct-08	Desire machine ability to reset after error condition 15 Limit maximum air pressure to 95 psi.
1.04	D	18-Nov-08	Mechanized Arc On operation needed to be enabled

WARNING

VOLTAGES IN PLASMA CUTTING EQUIPMENT ARE HIGH ENOUGH TO CAUSE SERIOUS INJURY OR POSSIBLY DEATH. BE CAREFUL AROUND EQUIPMENT WHEN THE COVERS ARE REMOVED.

10.1 Maintenance

A maintenance schedule should be created and based on the following variables, amount of usage, placement of machine and cleanliness of local environment. A maximum time between should be no more the 90 days.

External: Check work cable for worn insulation and confirm tight electrical connections. Check safety ground at work piece and at power source. Check torch cables for worn insulation and confirm tight electrical connections. Drain any moisture from the bowl of the input filter / regulator.

Internal: Check for discolored connections as they indicate a loose connection. Check all plugs, fittings and electrical connections for tightness. Make sure cables and hoses are not damaged, flattened or kinked. With input power disconnected and wearing proper eye and face protection, blow out accumulated dirt and foreign materials for the inside of unit. Extra attention should be given to the finned heatsinks.

CAUTION

Water or oil occasionally accumulates in compressed lines. Be sure to direct the first blast of air away from the equipment to avoid damage to the EPP400

10.2 Electrostatic Discharge

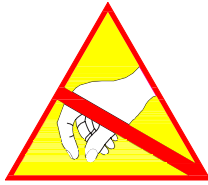

ESD

WARNING!

STATIC ELECTRICITY can damage circuit boards and electronic components.

- Observe precautions for handling electrostatic sensitive devices.
- Use proper static-proof bags and boxes.

What is ESD?

A sudden transfer or discharge of static electricity from one object to another. ESD stands for Electrostatic Discharge.

How does ESD damage occur?

ESD can cause damage to sensitive electrical components, but is not dangerous to people. ESD damage occurs when an ungrounded person or object with a static charge comes into contact with a component or assembly that is grounded. A rapid discharge can occur, causing damage. This damage can take the form of immediate failure, but it is more likely that system performance will be affected and the component will fail prematurely.

How do we prevent ESD damage?

ESD damage can be prevented by awareness. If static electricity is prevented from building up on you or on anything at your work station, then there cannot be any static discharges. Nonconductive materials (e.g. fabrics), or insulators (e.g. plastics) generate and hold static charge, so you should not bring unnecessary nonconductive items into the work area. It is obviously difficult to avoid all such items, so various means are used to drain off any static discharge from persons to prevent the risk of ESD damage. This is done by simple devices: wrist straps, connected to ground, and conductive shoes.

Work surfaces, carts and containers must be conductive and grounded, use only antistatic packaging materials. Overall, handling of ESD-sensitive devices should be minimized to prevent damage.

10.3 Ohm's and Watt's Laws

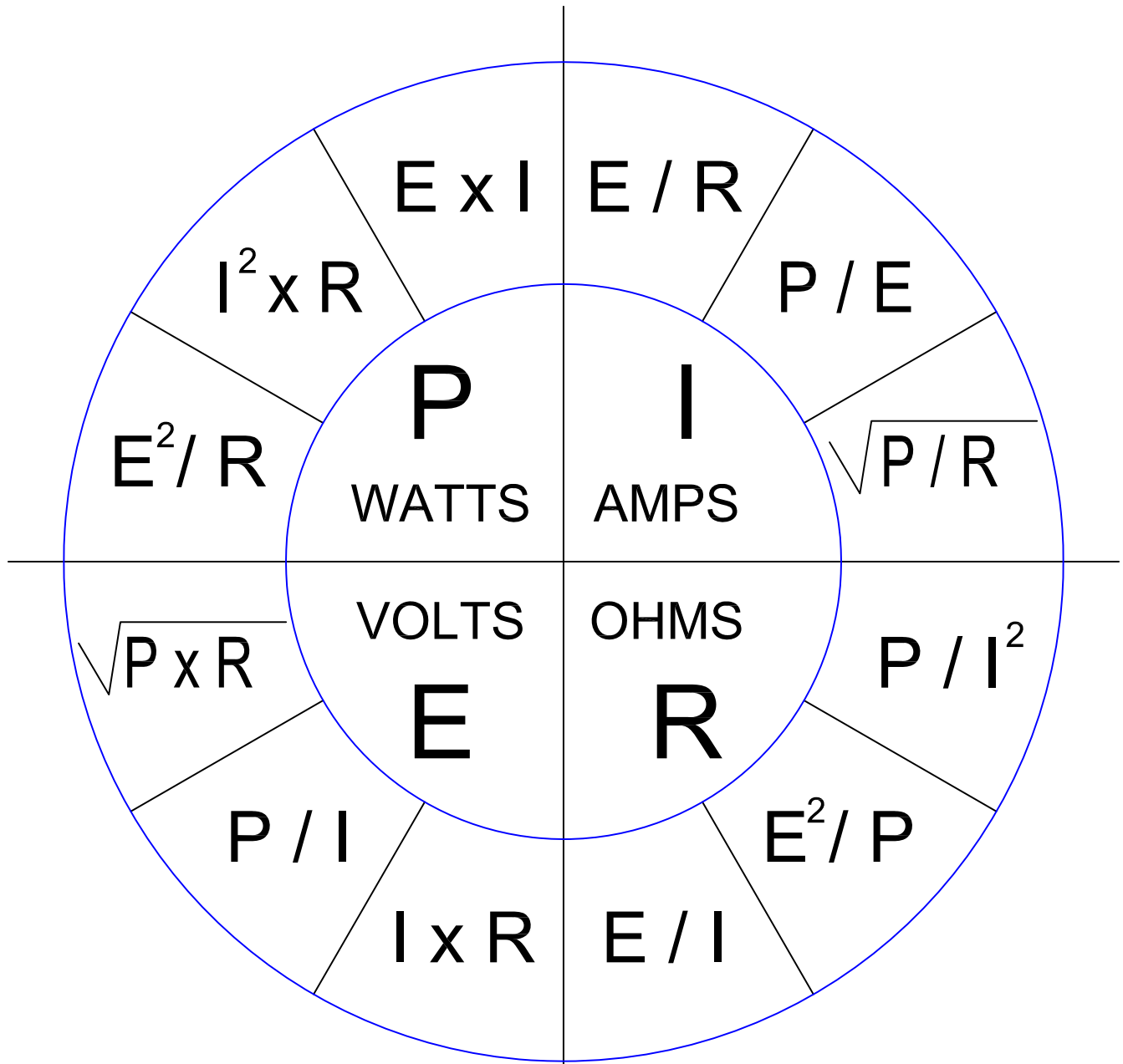

E = PRESSURE IN VOLTS

R = RESISTANCE IN OHMS

I = CURRENT IN AMPERES

W = POWER IN WATTS









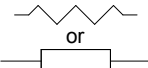

THE DIAGRAM ABOVE SHOWS ALL THE FORMULAS FOR DETERMINING E, I, AND R WITH OHM'S AND WATT'S LAWS.

To find W when E = 10 and R = 5, substitute 10 for E and 5 for R.

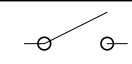
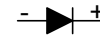

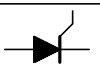







$$E^2 = 10 \times 10 = 100$$

$$100 / 5R = 20 \text{ WATTS}$$

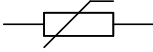
10.4 Glossary

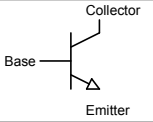
SYMBOL	NOTATION	NAME	VALUES	DESCRIPTION
	A	Amperage	n	Current: effectively the "amount of flow" of electricity.
	V	Volts	n	Electromotive force: effectively the "pressure" of electron movement.
	R	Resistance	n	Opposition to electron transfer: expressed in OHMS.
	W	Watt	n	A measure of Power. Watts = V*A
	F	Farad	n	Amount of electrical storage in a capacitor.
		BIAS		A voltage used to control or stabilize an electronic circuit. A forward bias is voltage applied in the direction of the current flow within a transistor, tube or circuit. A reverse bias is voltage applied in the opposite direction.
		OCV	n VOLTS	Open Circuit Voltage:
	n	Number		Indicates that any number may be used in its place.
	μ	micro	0.00000n	One Millionth of any unit.
	+	ANODE:		+ Positive element of device.
	-	CATHODE:		- Negative element of device - the banded end of a diode.
	C n	CAPACITOR	μF	Stores energy in the electrostatic field generated between two metal plates separated by an insulator. Typical values are in μF.
	C n	ELECTROLYTIC CAPACITOR	μF	Electrolytic capacitors will be damaged if polarity is not correct. Capacitors can charge themselves from ambient electric fields and should be handled with caution.
	R n	RESISTOR	Ω, W	Component that opposes current flow proportionately to its Ohm (Ω) rating. Power dissipation is expressed in Watts (Ω).
	F n	FUSE	n A, n V	Device in series with a load which opens the circuit if its current rating (A) is exceeded.
	SW n	SWITCH	n A, n V n P, n T	Device which opens and closes a circuit.
	D n	DIODE		A semi-conductor that conducts in only one direction
	D n	ZENER DIODE		A diode that permits high current flow without damage, the reverse voltage remains almost constant over a wide range of currents, used esp. to regulate voltage.
	D n	LIGHT EMITTING DIODE		Semiconductor diode that emits light when conducting current
	SCR	SILICON CONTROLLED RECTIFIER		Device having primary and secondary inductors for altering a-c signal amplitudes, impedance matching, and isolation purposes. A reverse blocking triode thyristor
	L n	COIL		Wound wire device; current through the coil generates a electromagnetic field causing inductive reactance, which increases with number of turns and density.
	L n	COIL (Iron Core)		Adding a core to a coil increases the inductance produced.
	T n	TRANSFORMER		Wound wire device with a primary and secondary coil(s) which increases or decreases voltage applied to the primary based on coil and core configuration. 1:1 transformers are used for isolation.
		GROUND		Identifies the earth (ground) connection. NOTE: Not for a protective earth connection.

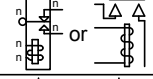
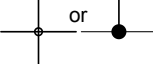
10.4 Glossary

SYMBOL	NOTATION	NAME	VALUES	DESCRIPTION
		NEUTRAL		Electronic neutral or common.
		PLUG CONNECTION		Variously configured male/female separable connectors.
	SOL n	SOLENOID		Electro-magnetically operated valve.
	M n	MOTOR	n Ø,HP,V	A device which converts electrical energy to mechanical energy (motion).
		THERMISTOR		A resistor whose resistance changes with temperature.
	T SW n	THERMAL SWITCH		Protective device that protects circuits from over temperature.
	Q n	TRANSISTOR		A transistor amplifies current. A small base current controls the larger collector current.
	TP n	TEST POINT		Dedicated location for obtaining quantification.
	K n	RELAY	n A, n V	Electro-mechanical device for opening / closing a circuit.
		WIRE NODE		Schematic representation of physical connection of wires.
	Y n	CRYSTAL	n MHz	Device using the mechanical resonance of a physical crystal of piezo-electric material to create an electrical signal with a very precise frequency.
		LAMP		Produces light by heating a filament.
		BIT		Short for binary digit, the smallest unit of information processed by a computer. A single bit can hold only one of two values: 0 or 1. As used in this manual BitI refers to input data, and BitO refers to output data.

10.4 Glossary

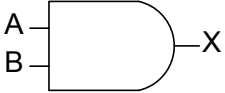
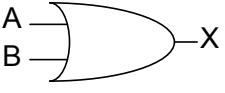
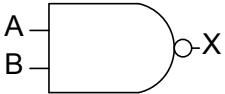
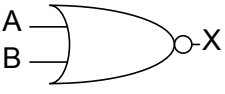
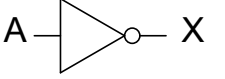
LOGIC SYMBOLS																				
SYMBOL	NAME	DESCRIPTION																		
	AND GATE	<p>An AND gate can have two or more inputs. The output of an AND gate is true when all its inputs are true.</p> <p style="text-align: center;">AND</p> <table border="1" style="margin-left: auto; margin-right: auto;"> <thead> <tr> <th colspan="2">INPUT</th> <th>OUTPUT</th> </tr> <tr> <th>A</th> <th>B</th> <th>$X = AB$</th> </tr> </thead> <tbody> <tr> <td>0</td> <td>0</td> <td>0</td> </tr> <tr> <td>0</td> <td>1</td> <td>0</td> </tr> <tr> <td>1</td> <td>0</td> <td>0</td> </tr> <tr> <td>1</td> <td>1</td> <td>1</td> </tr> </tbody> </table>	INPUT		OUTPUT	A	B	$X = AB$	0	0	0	0	1	0	1	0	0	1	1	1
INPUT		OUTPUT																		
A	B	$X = AB$																		
0	0	0																		
0	1	0																		
1	0	0																		
1	1	1																		
	OR GATE	<p>An OR gate can have two or more inputs. The output of an OR gate is true when at least one of its inputs is true.</p> <p style="text-align: center;">OR</p> <table border="1" style="margin-left: auto; margin-right: auto;"> <thead> <tr> <th colspan="2">INPUT</th> <th>OUTPUT</th> </tr> <tr> <th>A</th> <th>B</th> <th>$X = A+B$</th> </tr> </thead> <tbody> <tr> <td>0</td> <td>0</td> <td>0</td> </tr> <tr> <td>0</td> <td>1</td> <td>1</td> </tr> <tr> <td>1</td> <td>0</td> <td>1</td> </tr> <tr> <td>1</td> <td>1</td> <td>1</td> </tr> </tbody> </table>	INPUT		OUTPUT	A	B	$X = A+B$	0	0	0	0	1	1	1	0	1	1	1	1
INPUT		OUTPUT																		
A	B	$X = A+B$																		
0	0	0																		
0	1	1																		
1	0	1																		
1	1	1																		
	NAND GATE	<p>A NAND gate can have two or more inputs. The 'o' on the output means 'not' showing that it is a Not AND gate. The output of a NAND gate is true unless all its inputs are true.</p> <p style="text-align: center;">NAND</p> <table border="1" style="margin-left: auto; margin-right: auto;"> <thead> <tr> <th colspan="2">INPUT</th> <th>OUTPUT</th> </tr> <tr> <th>A</th> <th>B</th> <th>$X = \overline{A \cdot B}$</th> </tr> </thead> <tbody> <tr> <td>0</td> <td>0</td> <td>1</td> </tr> <tr> <td>0</td> <td>1</td> <td>1</td> </tr> <tr> <td>1</td> <td>0</td> <td>1</td> </tr> <tr> <td>1</td> <td>1</td> <td>0</td> </tr> </tbody> </table>	INPUT		OUTPUT	A	B	$X = \overline{A \cdot B}$	0	0	1	0	1	1	1	0	1	1	1	0
INPUT		OUTPUT																		
A	B	$X = \overline{A \cdot B}$																		
0	0	1																		
0	1	1																		
1	0	1																		
1	1	0																		
	NOR GATE	<p>A NOR gate can have two or more inputs. The 'o' on the output means 'not' showing that it is a Not OR gate. The output of a NOR gate is true when none of its inputs are true.</p> <p style="text-align: center;">NOR</p> <table border="1" style="margin-left: auto; margin-right: auto;"> <thead> <tr> <th colspan="2">INPUT</th> <th>OUTPUT</th> </tr> <tr> <th>A</th> <th>B</th> <th>$X = \overline{A+B}$</th> </tr> </thead> <tbody> <tr> <td>0</td> <td>0</td> <td>1</td> </tr> <tr> <td>0</td> <td>1</td> <td>0</td> </tr> <tr> <td>1</td> <td>0</td> <td>0</td> </tr> <tr> <td>1</td> <td>1</td> <td>0</td> </tr> </tbody> </table>	INPUT		OUTPUT	A	B	$X = \overline{A+B}$	0	0	1	0	1	0	1	0	0	1	1	0
INPUT		OUTPUT																		
A	B	$X = \overline{A+B}$																		
0	0	1																		
0	1	0																		
1	0	0																		
1	1	0																		
	NOT (INVERTER)	<p>A NOT gate can only have one input. The 'o' on the output means 'not'. The output of a NOT gate is the inverse (opposite) of its input, so the output is true when the input is false. A NOT gate is also called an inverter.</p> <p style="text-align: center;">NOT</p> <table border="1" style="margin-left: auto; margin-right: auto;"> <thead> <tr> <th>INPUT</th> <th>OUTPUT</th> </tr> <tr> <th>A</th> <th>$X = \overline{A}$</th> </tr> </thead> <tbody> <tr> <td>0</td> <td>1</td> </tr> <tr> <td>1</td> <td>0</td> </tr> </tbody> </table>	INPUT	OUTPUT	A	$X = \overline{A}$	0	1	1	0										
INPUT	OUTPUT																			
A	$X = \overline{A}$																			
0	1																			
1	0																			

10.5 Meter Use

Relay Voltage Drop as a means of voltage in circuit troubleshooting.

In all series circuits, the total circuit voltage is dropped across the load or electrical devices. The higher the resistance of the load the higher the voltage drop. The lower the load resistance the lower the voltage drop. An open contact in a branch circuit with a load will show a high voltage drop because the meter and the open switch have a very high resistance when compared to the load. While a closed contact that has a meter across it, it shows a very low voltage drop since the resistance across the switch is lower than the load. So, using the meter set at the proper voltage range you can test if the contacts are closed or open.

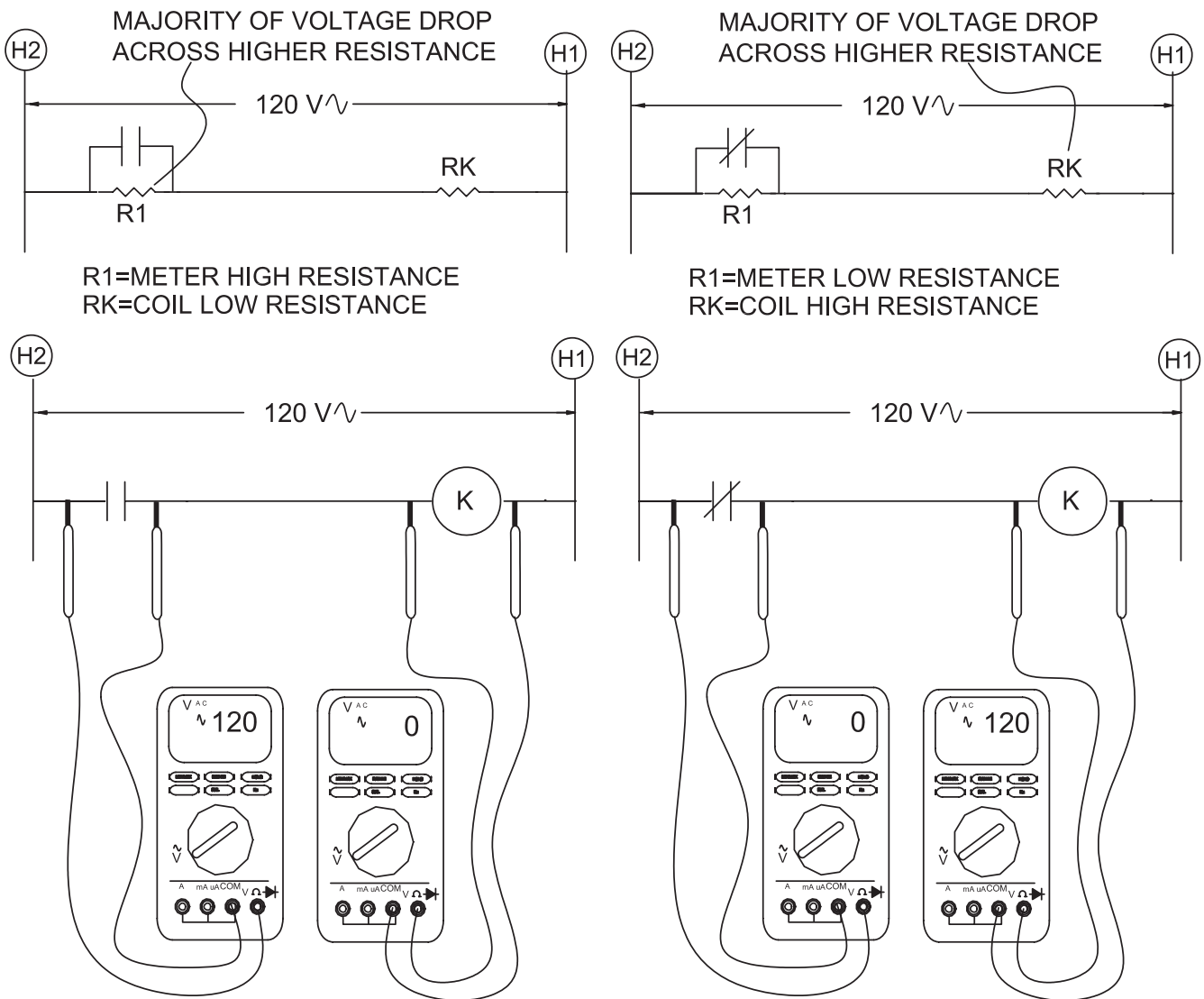

10.6 Ohm Testing

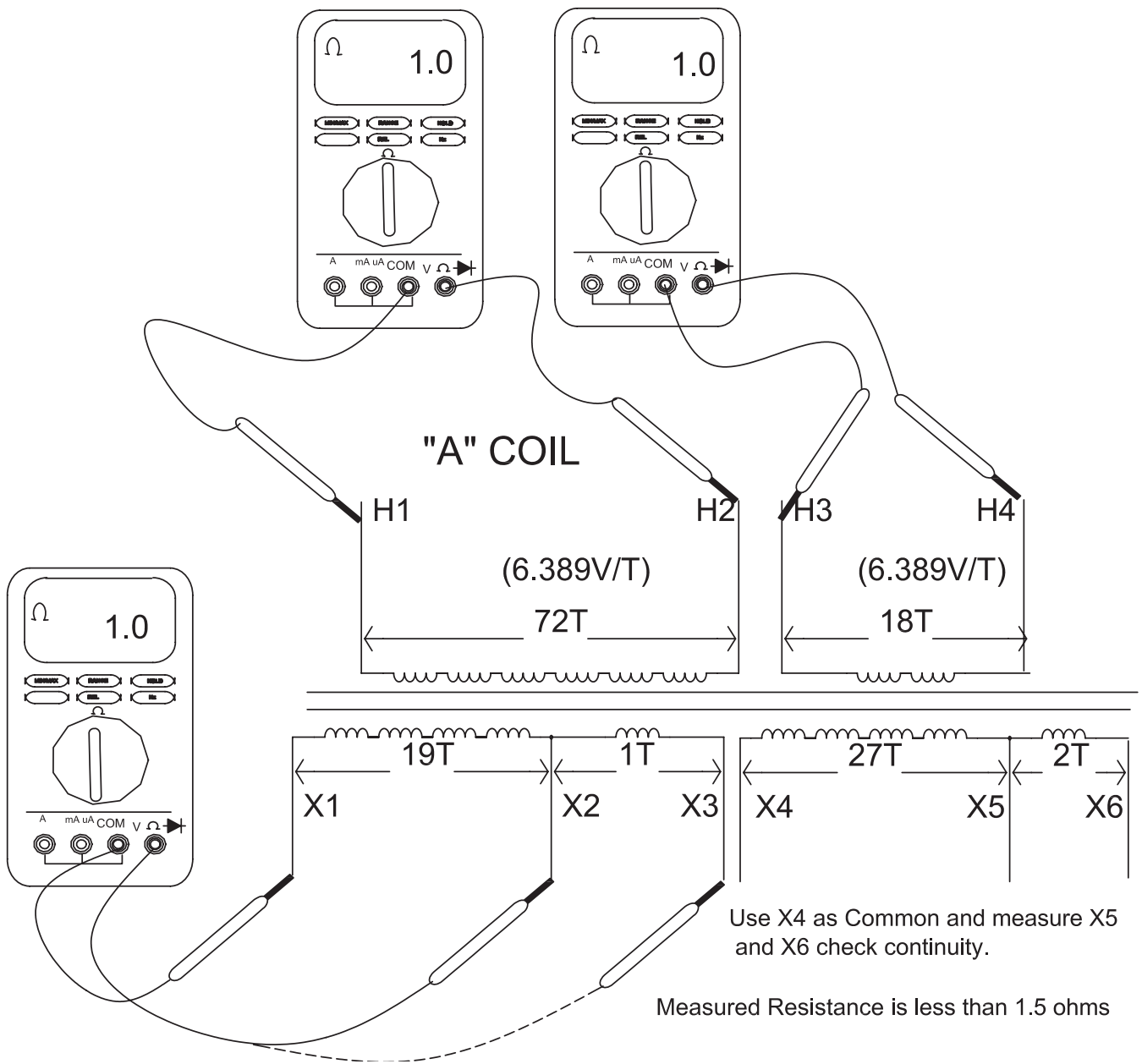

10.7 Diode Testing

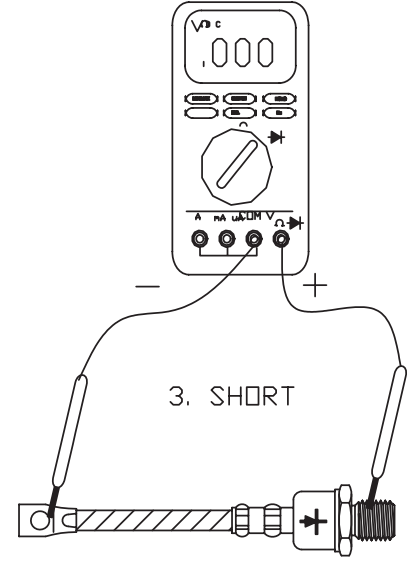
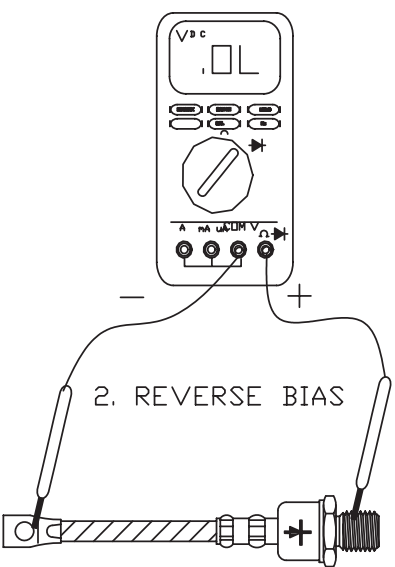
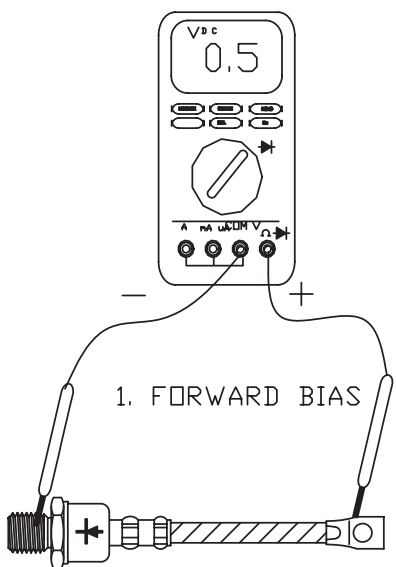
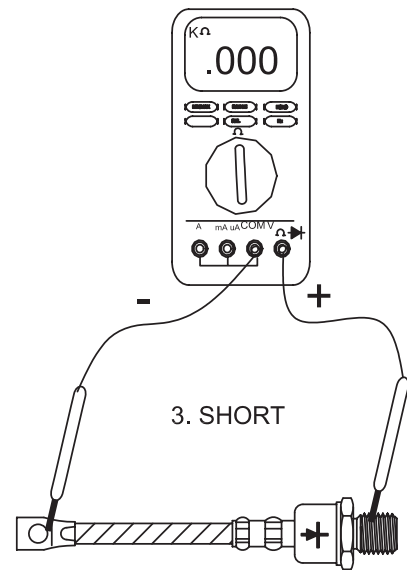
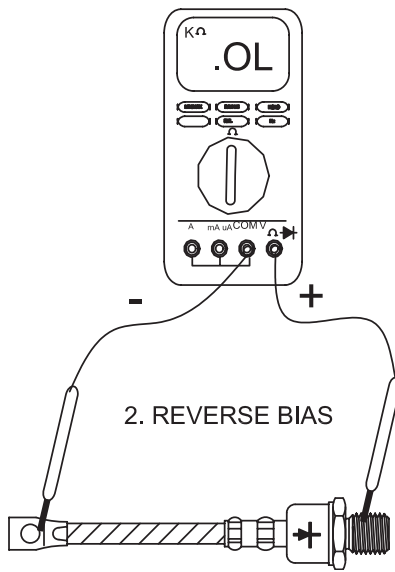
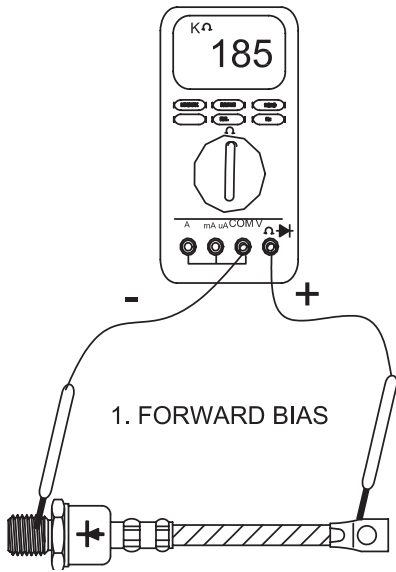

10.8 Ripple

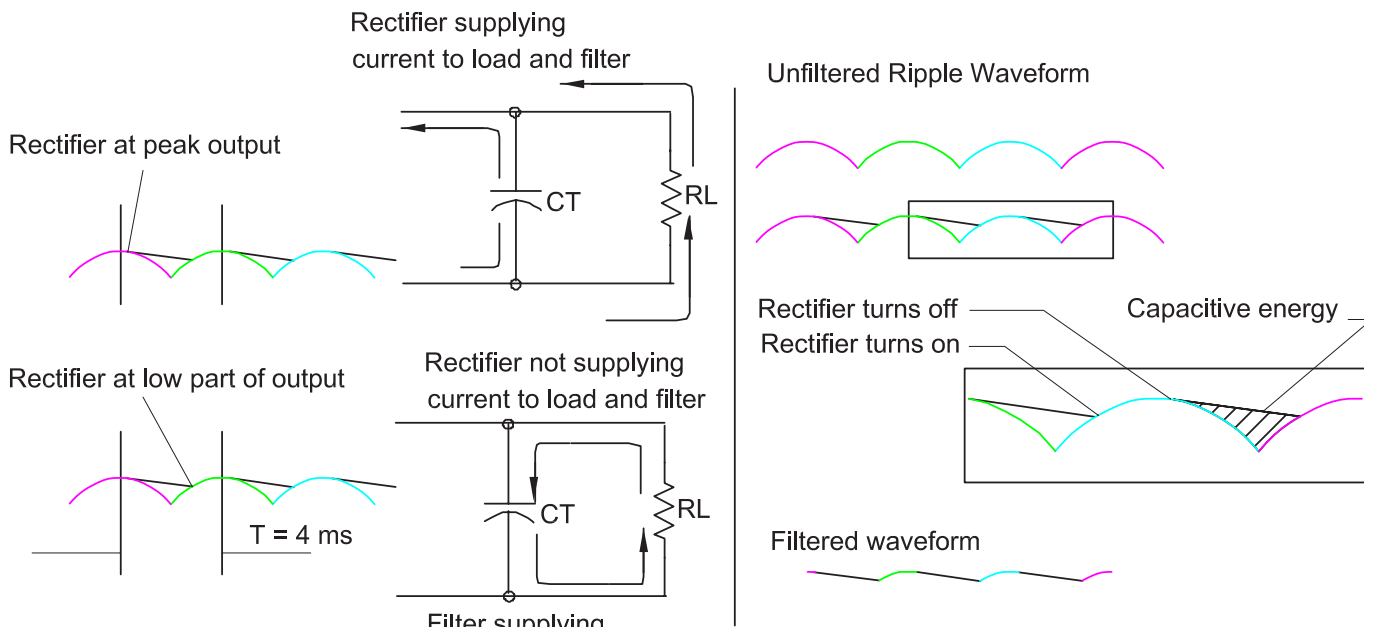
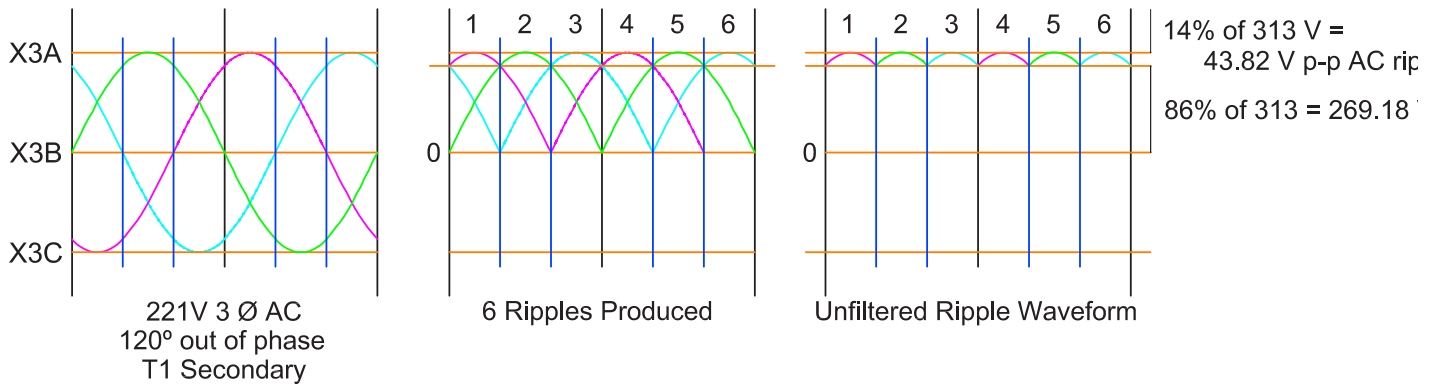

10.9 Voltage Measurement

Voltage measurement from the 3 phase AC V Delta primary and Wye secondary 3 phase AC V output for the bridge rectifier

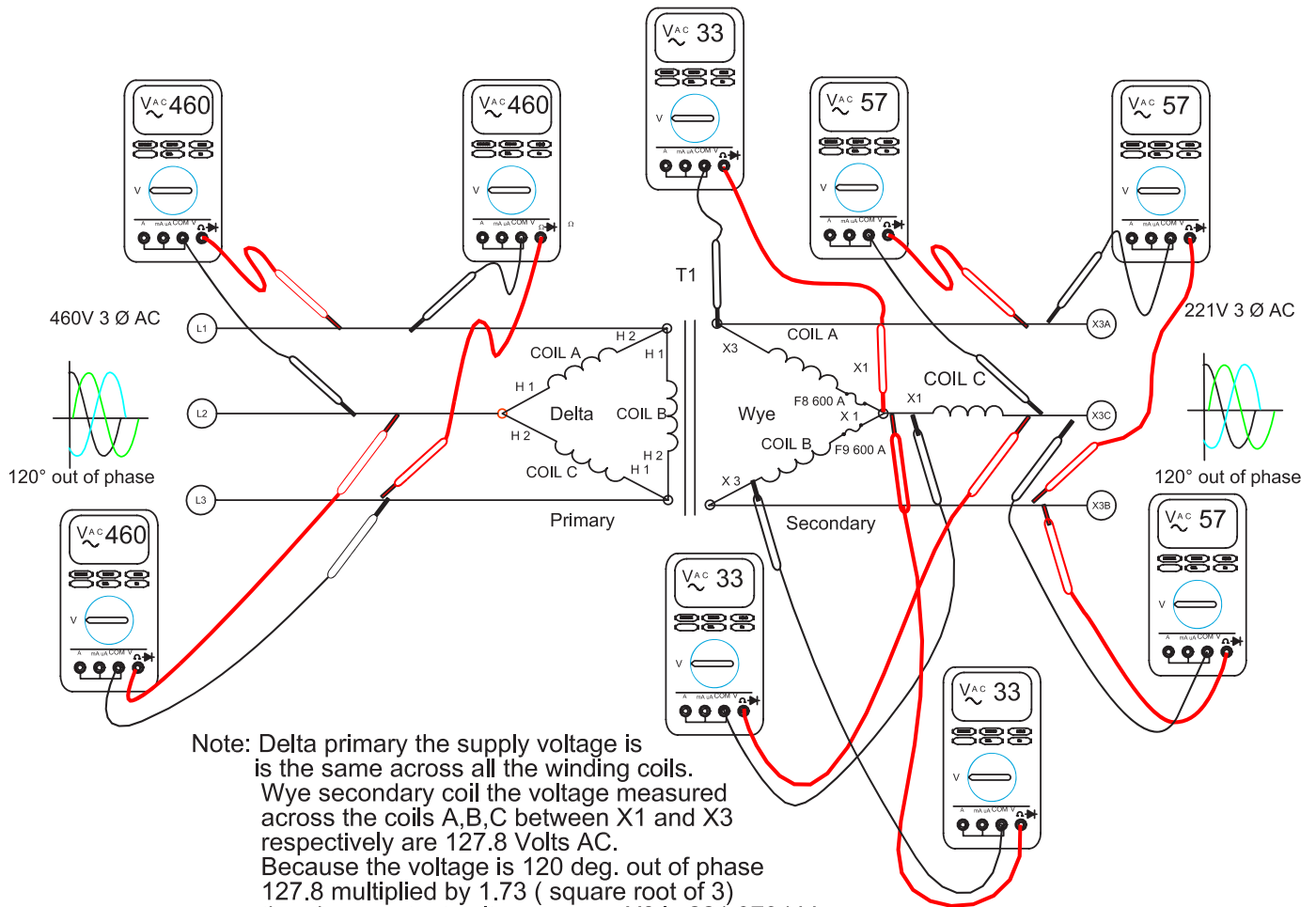

10.10 Generic IGBT Testing

IGBT Handling & Replacement

Since IGBT gates are insulated from any other conducting region, care should be taken to prevent static build up, which could possibly damage gate oxides. All IGBT modules are shipped from the factory with conductive foam contacting the gate and emitter sense pins. Always ground parts touching the gate pins during installation. In general, standard ESD predictions application to FETs should be followed.

Other handling precautions that should also be observed are as follows:

- Use grounded work station with grounded floors and grounded wrist straps when handling devices.
- Use a 100W resistor in series with the gate when performing curve tracer tests.
- Never install devices into systems with power connected to the system.
- Use soldering irons with grounded tips when soldering to gate terminals.

When mounting IGBT modules on a heatsink, certain precautions should be taken to prevent any damage against a sudden torque. If a sudden torque (“one-sided tightening”) is applied at only one mounting terminal the ceramic insulation plate or silicon chip inside the module may get damaged.

The mounting screws are to be fastened in the order shown below, also, care must be taken to achieve maximum contact (i.e. minimum contact thermal resistance) for the best heat dissipation.

Application of a thermal pad on the contact surface improves its thermal conductivity. See Replacement Parts section for the required pad.

When an IGBT fails in these “inverter” units, BOTH IGBTs must be replaced. Failure of a transistor will subject stress into the circuit, and on the input bridge. It is advised that the input bridge also be replaced when a transistor failure has occurred.

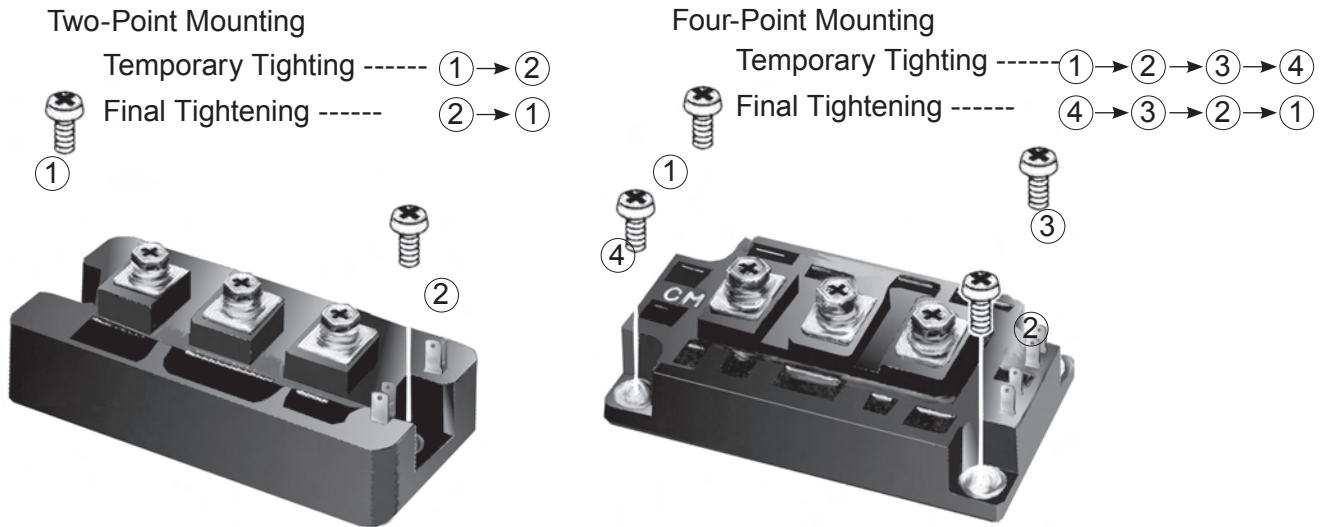

MOUNTING SCREW TORQUES			
Screw Size	Description	Torque (Eng)	Torque (Metric)
M4	Gate Terminal	12-14 in-lb	1.36 - 1.58 N-M
M5	Electrical Connections	19-22 in-lb	2.15 - 2.481 N-M
M6	Mounting Screw	26-28 in-lb	2.94 - 3.16 N-M

10.10.1 IGBT Testing

Take measurements on threaded part below insulated chrome plated spacer.

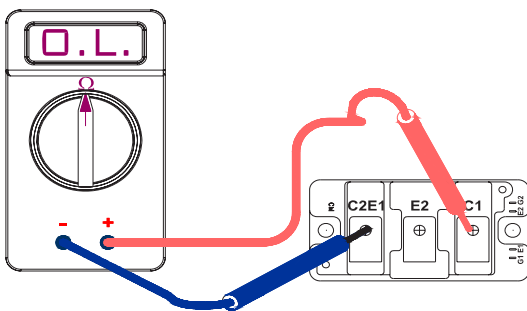
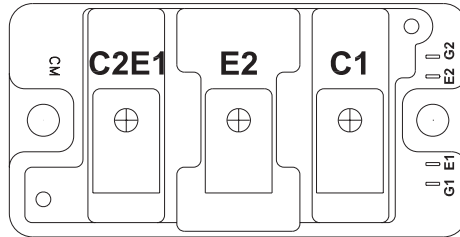

With meter on "OHMS (Ω)" setting, measure resistance by placing the red (+) lead on the Collector (C1) and the black (-) lead on the Emitter (C2E1) of the IGBT.

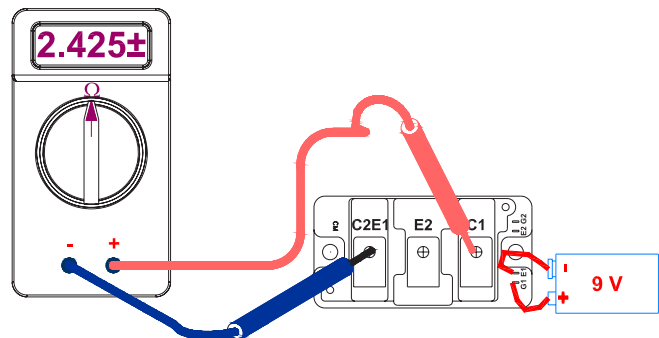

Connect a 9 VDC battery with the negative on the Emitter (E1) and the positive on the Gate (G1). The meter should register a low reading.

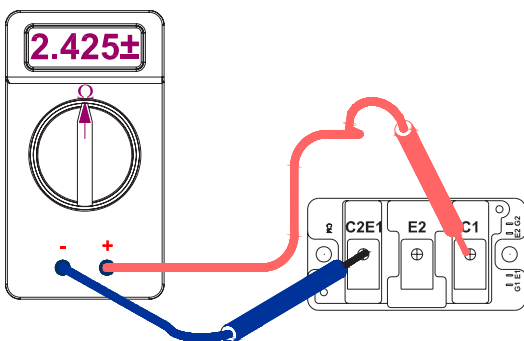

The Gate should remain on once it has activated.

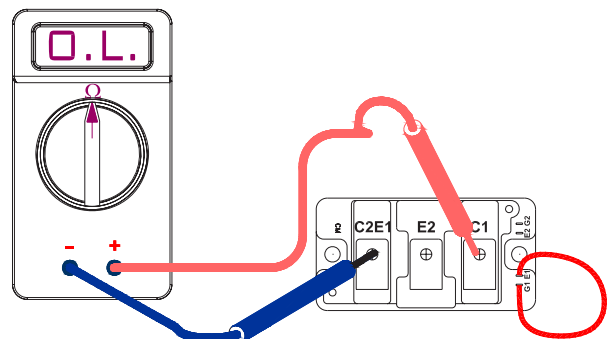

Short the Emitter / Gate (G1-E1) leads to turn the IGBT off.

10.10.1 IGBT Testing

Take measurements on threaded part below insulated chrome plated spacer.

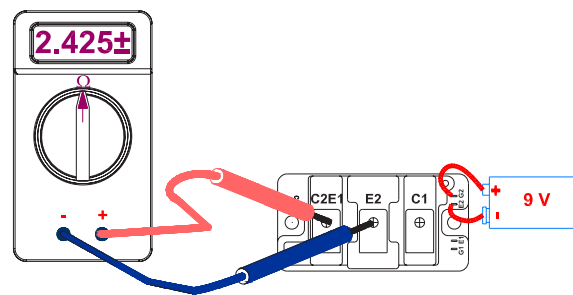
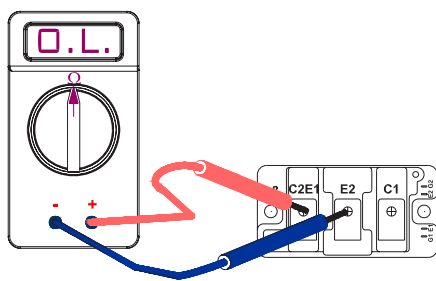
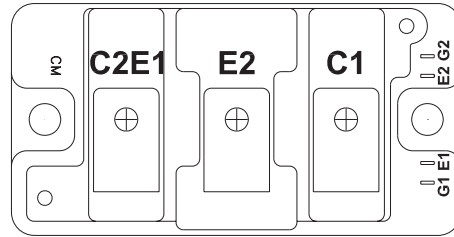

With meter on “OHMS (Ω)” setting, measure resistance by placing the red (+) lead on the Collector (C3 E1) and the black (-) lead on the Emitter (E2) of the IGBT.

Connect a 9 VDC battery with the negative on the Emitter (E2) and the positive on the Gate (G2). The meter should register a low reading.

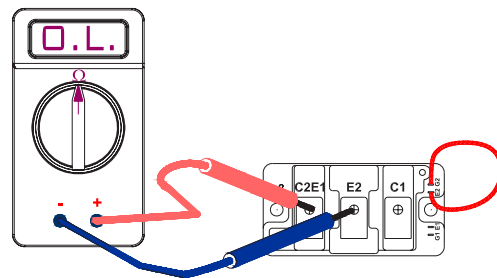
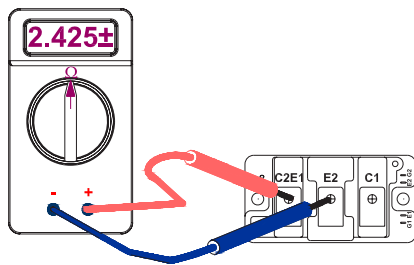

The Gate should remain on once it has activated.

Short the Emitter / Gate (G2-E2) leads to turn the IGBT off.

10.10.1 IGBT Testing

IGBT TESTER SCHEMATIC

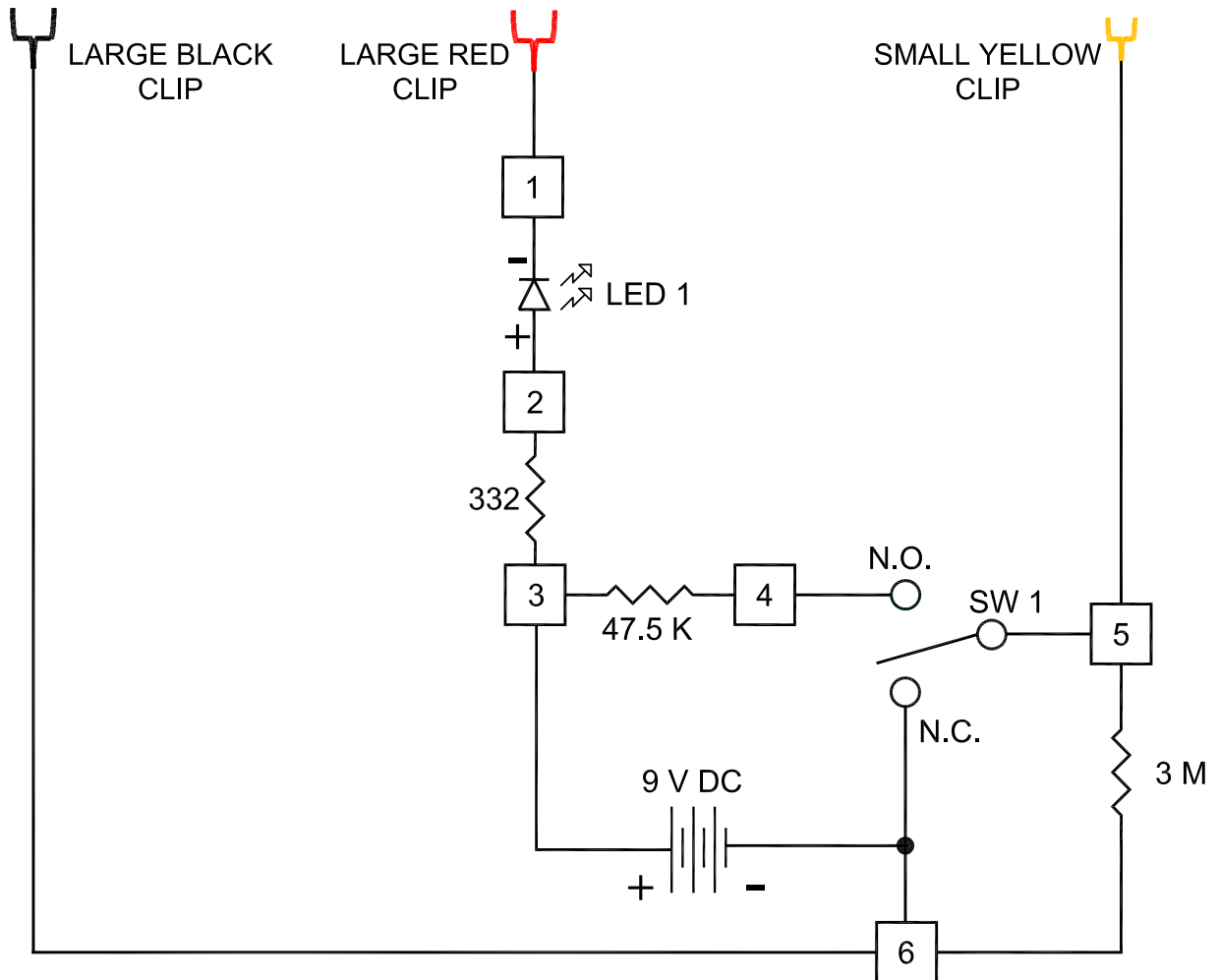

10.10.1 IGBT Information

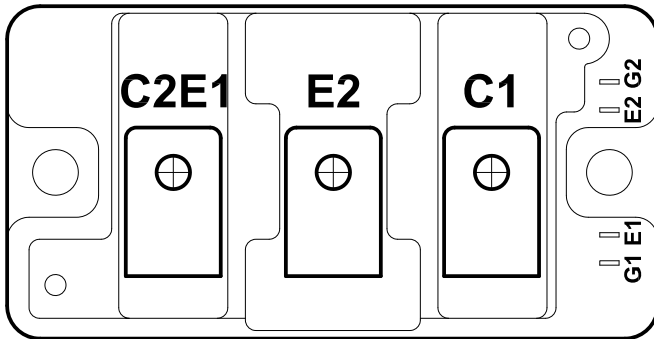

IGBT TESTING



Static Electricity Can Damage Circuit Boards And Electronic Components.

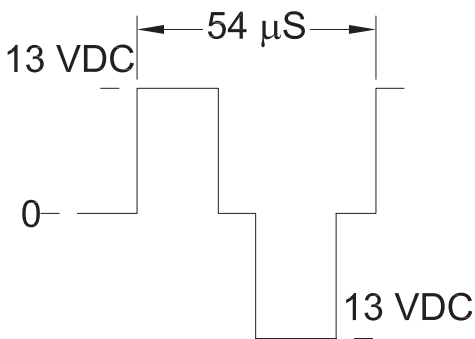
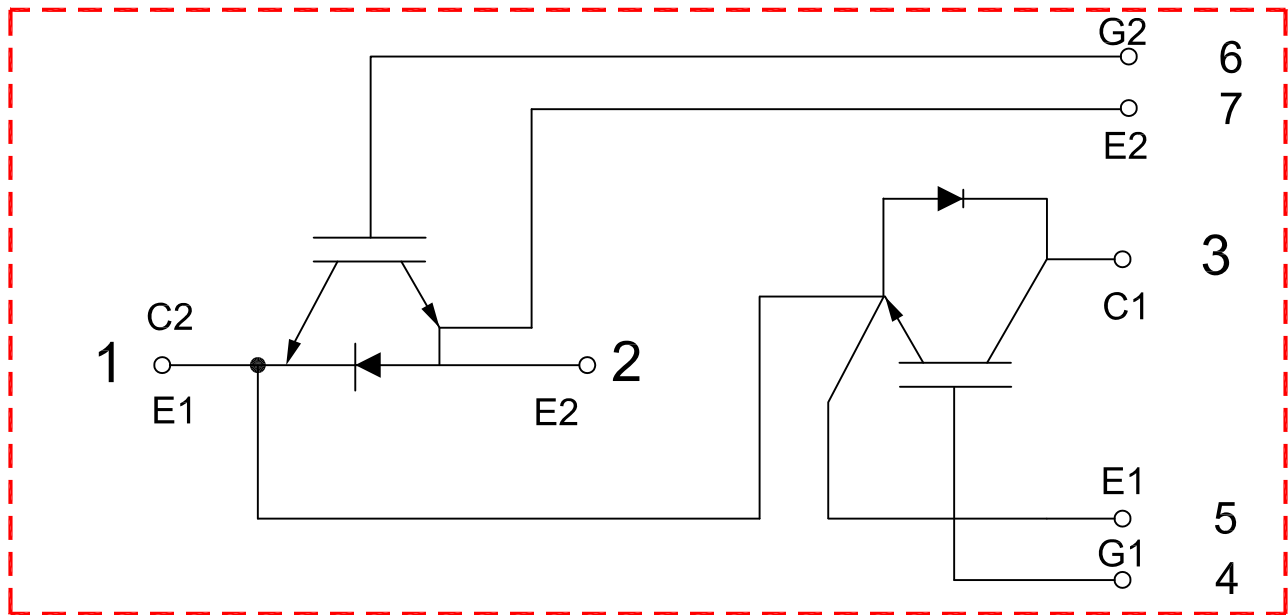

IGBT Gating Signal

Completely clean mating surfaces and apply thermal conducting paste / tape.

NOTE:

Small amounts of dirt between mating surfaces can cause component failure or degraded performance; DO NOT use silicon seal or other adhesives in place of thermal paste.

With a torque wrench evenly and alternately tighten mounting screws to proper torque. Uneven or excessive tightening will damage or destroy the device.

10.11 Buss Supply Power Control / IGBT / MOSFET Testing

IGBT TESTER

IGBT

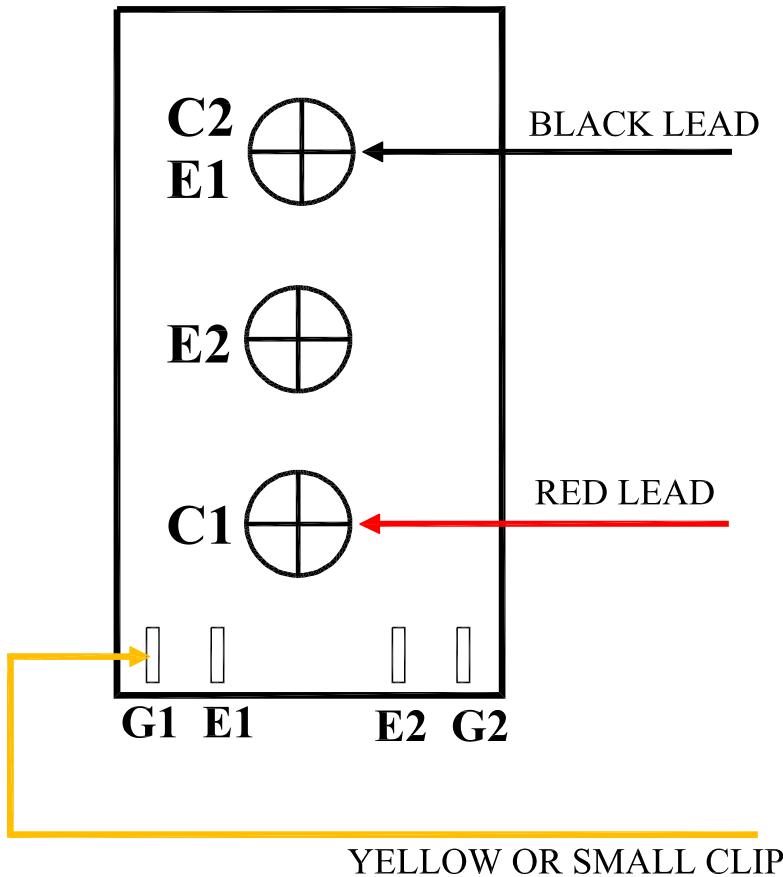

1. Connect as shown
2. Led On = Shorted Junction, Replace Part
3. Press Push-button Switch:
 - Led On = Good
 - Led Off = Bad Or Open, Replace Part

** Repeat steps for E2, C2 and G2

NOTE:
 Black lead always on emitter
 Red lead always on collector
 Yellow on gate connections

- G1 = GATE 1
- G2 = GATE 2
- E1 = EMITTER 1
- E2 = EMITTER 2
- C1 = COLLECTOR 1
- C2 = COLLECTOR 2

1. Connect as shown
2. Led On = Shorted Junction, Replace Part
3. Press Push-button Switch:
 - Led On = Good
 - Led Off = Bad Or Open, Replace Part

MOSFET

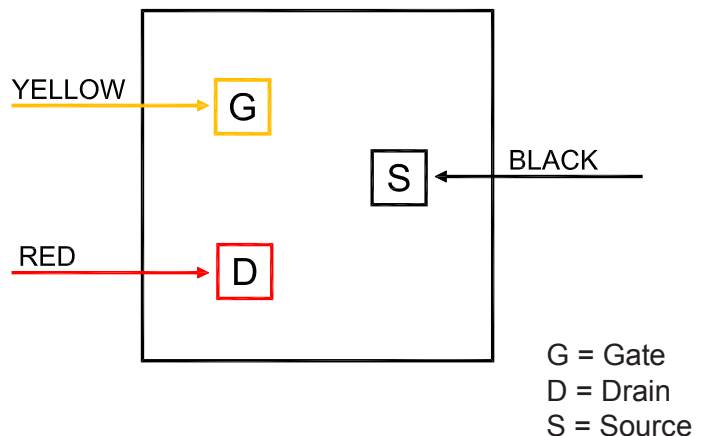

Index

BR1	3, 27, 56, 74, 75, 81, 119
buss	165
C1	165
D1	49, 87
D4	49, 87
D101	26, 33
D102	26, 33
IGBT	59, 72, 73, 160, 161, 162, 163, 164, 165
K1	68
L1	49, 51
L2	52
M1	26
PCB1	34, 35, 36, 37, 38, 39, 40, 41, 42, 43, 44, 45, 46, 47, 48, 49, 50, 68
PCB2	43, 56, 57, 61, 62, 63, 64, 65, 66, 67, 68, 69, 70, 71, 73, 76, 77, 78, 79, 80, 81, 82, 83, 84
PCB3	85, 87, 91
PCB4	3, 79, 85, 87, 118
PCB5	90, 91, 119
PCB6	3, 65, 97, 98, 99
PCB7	95
Q101	58, 119
Q102	58, 119
Q103	90, 119
SOL1	3, 96, 118
SW1	50
SW2	30, 50
T1	31, 32, 87
T2	22, 23, 24, 25, 87, 107, 108, 109, 110, 111, 112, 113, 114, 115
torque	164
TS1	88, 89

REVISION HISTORY

1. Original release - 11/2008
2. Update drawings/BOMs to 0558007540 Rev C

ESAB subsidiaries and representative offices

Europe AUSTRIA ESAB Ges.m.b.H Vienna-Liesing Tel: +43 1 888 25 11 Fax: +43 1 888 25 11 85 BELGIUM S.A. ESAB N.V. Brussels Tel: +32 2 745 11 00 Fax: +32 2 745 11 28 BULGARIA ESAB Kft Representative Office Sofia Tel/Fax: +359 2 974 42 88 THE CZECH REPUBLIC ESAB VAMBERK s.r.o. Vamberk Tel: +420 2 819 40 885 Fax: +420 2 819 40 120 DENMARK Aktieselskabet ESAB Herlev Tel: +45 36 30 01 11 Fax: +45 36 30 40 03 FINLAND ESAB Oy Helsinki Tel: +358 9 547 761 Fax: +358 9 547 77 71 FRANCE ESAB France S.A. Cergy Pontoise Tel: +33 1 30 75 55 00 Fax: +33 1 30 75 55 24 GERMANY ESAB GmbH Solingen Tel: +49 212 298 0 Fax: +49 212 298 218 GREAT BRITAIN ESAB Group (UK) Ltd Waltham Cross Tel: +44 1992 76 85 15 Fax: +44 1992 71 58 03 ESAB Automation Ltd Andover Tel: +44 1264 33 22 33 Fax: +44 1264 33 20 74 HUNGARY ESAB Kft Budapest Tel: +36 1 20 44 182 Fax: +36 1 20 44 186 ITALY ESAB Saldatura S.p.A. Mesero (Mi) Tel: +39 02 97 96 81 Fax: +39 02 97 28 91 81 THE NETHERLANDS ESAB Nederland B.V. Amersfoort Tel: +31 33 422 35 55 Fax: +31 33 422 35 44	NORWAY AS ESAB Larvik Tel: +47 33 12 10 00 Fax: +47 33 11 52 03 POLAND ESAB Sp.zo.o. Katowice Tel: +48 32 351 11 00 Fax: +48 32 351 11 20 PORTUGAL ESAB Lda Lisbon Tel: +351 8 310 960 Fax: +351 1 859 1277 ROMANIA ESAB Romania Trading SRL Bucharest Tel: +40 316 900 600 Fax: +40 316 900 601 RUSSIA LLC ESAB Moscow Tel: +7 (495) 663 20 08 Fax: +7 (495) 663 20 09 SLOVAKIA ESAB Slovakia s.r.o. Bratislava Tel: +421 7 44 88 24 26 Fax: +421 7 44 88 87 41 SPAIN ESAB Ibérica S.A. Alcalá de Henares (MADRID) Tel: +34 91 878 3600 Fax: +34 91 802 3461 SWEDEN ESAB Sverige AB Gothenburg Tel: +46 31 50 95 00 Fax: +46 31 50 92 22 ESAB international AB Gothenburg Tel: +46 31 50 90 00 Fax: +46 31 50 93 60 SWITZERLAND ESAB AG Dietikon Tel: +41 1 741 25 25 Fax: +41 1 740 30 55 UKRAINE ESAB Ukraine LLC Kiev Tel: +38 (044) 501 23 24 Fax: +38 (044) 575 21 88	North and South America ARGENTINA CONARCO Buenos Aires Tel: +54 11 4 753 4039 Fax: +54 11 4 753 6313 BRAZIL ESAB S.A. Contagem-MG Tel: +55 31 2191 4333 Fax: +55 31 2191 4440 CANADA ESAB Group Canada Inc. Mississauga, Ontario Tel: +1 905 670 02 20 Fax: +1 905 670 48 79 MEXICO ESAB Mexico S.A. Monterrey Tel: +52 8 350 5959 Fax: +52 8 350 7554 USA ESAB Welding & Cutting Products Florence, SC Tel: +1 843 669 44 11 Fax: +1 843 664 57 48 Asia/Pacific CHINA Shanghai ESAB A/P Shanghai Tel: +86 21 2326 3000 Fax: +86 21 6566 6622 INDIA ESAB India Ltd Calcutta Tel: +91 33 478 45 17 Fax: +91 33 468 18 80 INDONESIA P.T. ESABindo Pratama Jakarta Tel: +62 21 460 0188 Fax: +62 21 461 2929 JAPAN ESAB Japan Tokyo Tel: +81 45 670 7073 Fax: +81 45 670 7001 MALAYSIA ESAB (Malaysia) Snd Bhd USJ Tel: +603 8023 7835 Fax: +603 8023 0225 SINGAPORE ESAB Asia/Pacific Pte Ltd Singapore Tel: +65 6861 43 22 Fax: +65 6861 31 95	SOUTH KOREA ESAB SeAH Corporation Kyungnam Tel: +82 55 269 8170 Fax: +82 55 289 8864 UNITED ARAB EMIRATES ESAB Middle East FZE Dubai Tel: +971 4 887 21 11 Fax: +971 4 887 22 63 Africa EGYPT ESAB Egypt Dokki-Cairo Tel: +20 2 390 96 69 Fax: +20 2 393 32 13 SOUTH AFRICA ESAB Africa Welding & Cutting Ltd Durbanvill 7570 - Cape Town Tel: +27 (0)21 975 8924 Distributors <i>For addresses and phone numbers to our distributors in other countries, please visit our home page</i> www.esab.com
--	--	--	---



ESAB AB
SE-695 81 LAXÅ
SWEDEN
Phone +46 584 81 000

www.esab.com

