

LKA 180/240

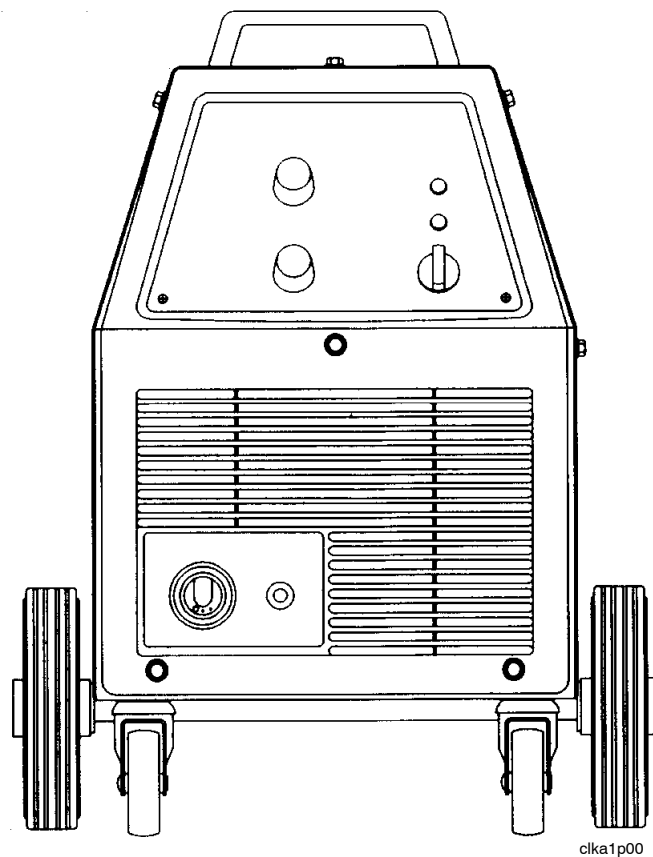

clka1p00

Service manual

INTRODUCTION	1
RATING PLATE	2
COMPONENT DESCRIPTION, LKA 180/240	4
CONNECTION DIAGRAM, LKA 180 Single-phase, 230 V .	5
CONNECTION DIAGRAM, LKA 180 3-phase, 400 V	6
CONNECTION DIAGRAM, LKA 180 3-phase, 230/400 V .	7
CONNECTION DIAGRAM, LKA 240 3-phase, 400 V	8
CONNECTION DIAGRAM, LKA 240 3-phase, 230/400 V .	9
CIRCUIT DIAGRAM, CIRCUIT BOARD AP1	10
COMPONENT POSITIONS, CIRCUIT BOARD AP1	12
DESCRIPTION OF OPERATION, CIRCUIT BOARD AP1 ...	13
LOAD CHARACTERISTICS	17
TECHNICAL DATA	18
INSTALLATION	19
OPERATION	20
MAINTENANCE	21
WELDING DATA SELECTION	21
SPARE PARTS LIST LKA 180/240	24

INTRODUCTION

This service manual is intended for use by technicians with electrical training when carrying out fault tracing and repair of the equipment.

At the end of the manual, there is a brief guide to using the machine in order to assist in understanding the machine.

The manual contains all design modifications introduced up to and including September 2004.

Use the diagrams in the manual when tracing faults. The machine components are described in alphabetical order on the pages foregoing the connection diagram.

The LKA 180 and 240 are designed and tested in accordance with international standard EN 60974-1, EN 50199.
On completion of service or repair work, it is the responsibility of the person(s) etc. performing the work to ensure that the product does not depart from the requirements of the above standard.



WARNING



ARC WELDING AND CUTTING CAN BE INJURIOUS TO YOURSELF AND OTHERS. TAKE PRECAUTIONS WHEN WELDING. ASK FOR YOUR EMPLOYER'S SAFETY PRACTICES WHICH SHOULD BE BASED ON MANUFACTURERS' HAZARD DATA.

ELECTRIC SHOCK – Can kill

- Install and earth the welding unit in accordance with applicable standards.
- Do not touch live electrical parts or electrodes with bare skin, wet gloves or wet clothing.
- Insulate yourself from earth and the workpiece.
- Ensure your working stance is safe.

FUMES AND GASES – Can be dangerous to health

- Keep your head out of the fumes.
- Use ventilation, extraction at the arc, or both, to keep fumes and gases from your breathing zone and the general area.

ARC RAYS – Can injure eyes and burn skin.

- Protect your eyes and body. Use the correct welding screen and filter lens and wear protective clothing.
- Protect bystanders with suitable screens or curtains.

FIRE HAZARD

- Sparks (spatter) can cause fire. Make sure therefore that there are no inflammable materials nearby.

MALFUNCTION – Call for expert assistance in the event of malfunction.









READ AND UNDERSTAND THE OPERATING MANUAL BEFORE INSTALLING OR OPERATING.

PROTECT YOURSELF AND OTHERS!

Rights reserved to alter specifications without notice.

RATING PLATE

The rating plate is secured to the back of the machine. The example shown below is the rating plate for an LKA 240 with an explanation of how the plate should be read and interpreted.

	ESAB AB S-402 77 Göteborg Sweden					
1	LKA 240		XXX YYY ZZZ			
2			EN 60974-1 EN 50199			
3		30A/15V - 200A/24V				
			20%	60%	100%	
		$U_0=36V$	I_2	200A	120A	85A
			U_2	24V	20V	18V
4		$U_1=400V$ 50Hz	I_1	11A	5A	4A
5			IP21			

1. LKA 240 is the type designation for this power source. The first letter, L, indicates that the LKA 240 is a rectifier, while K indicates Compact (Kompakt in Swedish) and A indicates the design generation.
The 240 indicates the maximum welding current.

2. These symbols indicate that the LKA 240 incorporates a transformer and rectifier.

3. This section indicates the voltage/current characteristic when welding and a current range of 30 - 200 A.
The voltage values of 15 and 24 V in the heading indicate that we comply with the international arc characteristic as defined in IEC 974-1.

X = The duty cycle, indicating for how long a time welding can be carried out at the specified welding data, expressed as a percentage of a ten-minute period.

I_2 = The current at the respective duty factors.

U_2 = The arc line characteristic voltage.

U_0 = The open-circuit voltage.

4. Indicates that the unit is intended for connection to a 400 V three-phase supply at 50 or 60 Hz.

I_1 = primary currents at the various load points.

5. IP21 indicates the enclosure class in respect of protection against penetrating objects and water. Enclosure class IP21 indicates that the equipment is intended for indoor use, while IP23 equipment is also suitable for outdoor use.

The  symbol indicates that the rectifier is designed for use in areas of elevated electrical risk.

6. The machine's serial number, in the form of three groups of figures (xxx yyy zzz).

The first group (xxx) indicates the version. The figures represent the year and week of approval of the version.

The second group (yyy) shows the year and week of final testing of the machine. For example, 341 indicates Week 41, 1993.

The final group (zzz) consists of three or four figures, and is a serial number in the range 0001 to 9999.

7. Shows that ESAB complies with the international standard, IEC 974- 1.

COMPONENT DESCRIPTION, LKA 180/240

The following component description refers to the connection diagrams on the following pages.

- AP1** Circuit board with control electronics: see the diagram on page 10 and description on page 13.
- C1–C3** Capacitor PME 0.1 μ F, 400 VDC, transient and HF protection.
- EV1** Fan, 24 VDC, fitted in the LKA 240 and the single-phase version of the LKA 180.
- HL1** Lamp, 28 V, white, lights when the main switch is On.
- KM1** Contactor, 42 V operating voltage.
- L1** Inductor.
- M1** Wire feed unit motor.
- QF1** Switch, 7-way in the LKA 180 and 10-way in the LKA 240.
- R1** Resistor, 1 Ω , only fitted in the single-phase version of LKA 180.
- R2** Resistor, 5.6 k Ω 5 W, only fitted in the single-phase version of LKA 180.
- SB1** Welding torch trigger switch
- ST1** Thermal overload cutout, for protection against overload, fitted in the winding of main transformer TM1. The switch operates (opens) at a temperature of 120 °C.
- ST2** Thermal overload cutout, for protection against overload, fitted on the diode bridge cooling fins (V1 – V6). It operates (breaks) at 110 °C in the single-phase version of the LKA 180 and at 130 °C in other machines.
- TC1** Control power supply transformer.
Supplied at 230 or 400 V and protected by a 1.6 A anti-surge fuse.
Secondary output voltages of 42, 27 and 20 V to circuit board AP1.
- TM1** Main transformer.
- V1–V6** Diode bridge, rectifier.
- V7** LED, yellow. Lights if thermal overload cutouts ST1 or ST2 operate as a result of high temperature.
- XS1** 9-pole connector.
- XS2** 5-pole connector.
- XS3** 7-pole connector.
- XS4** 2-pole connector.
- XT1** Mains terminal block, 5-way.
- XT2** Terminal block, positive and negative welding voltages.
- XT3** 6-pole terminal block for mains voltage selection.
Fitted only in the multi-voltage versions of the machine.
- YV1** Solenoid valve

CONNECTION DIAGRAM, LKA 180 Single-phase, 230 V

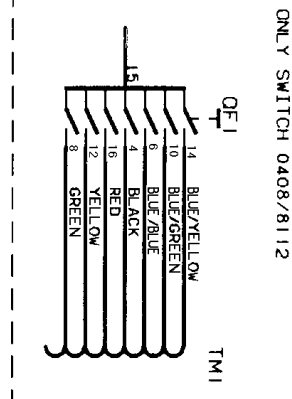
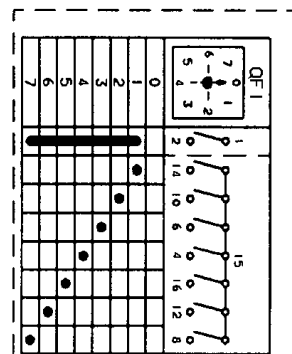
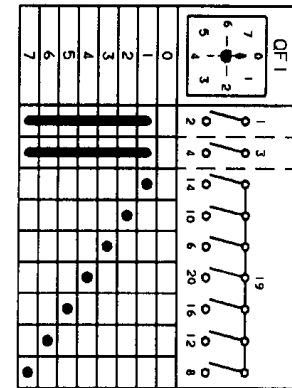
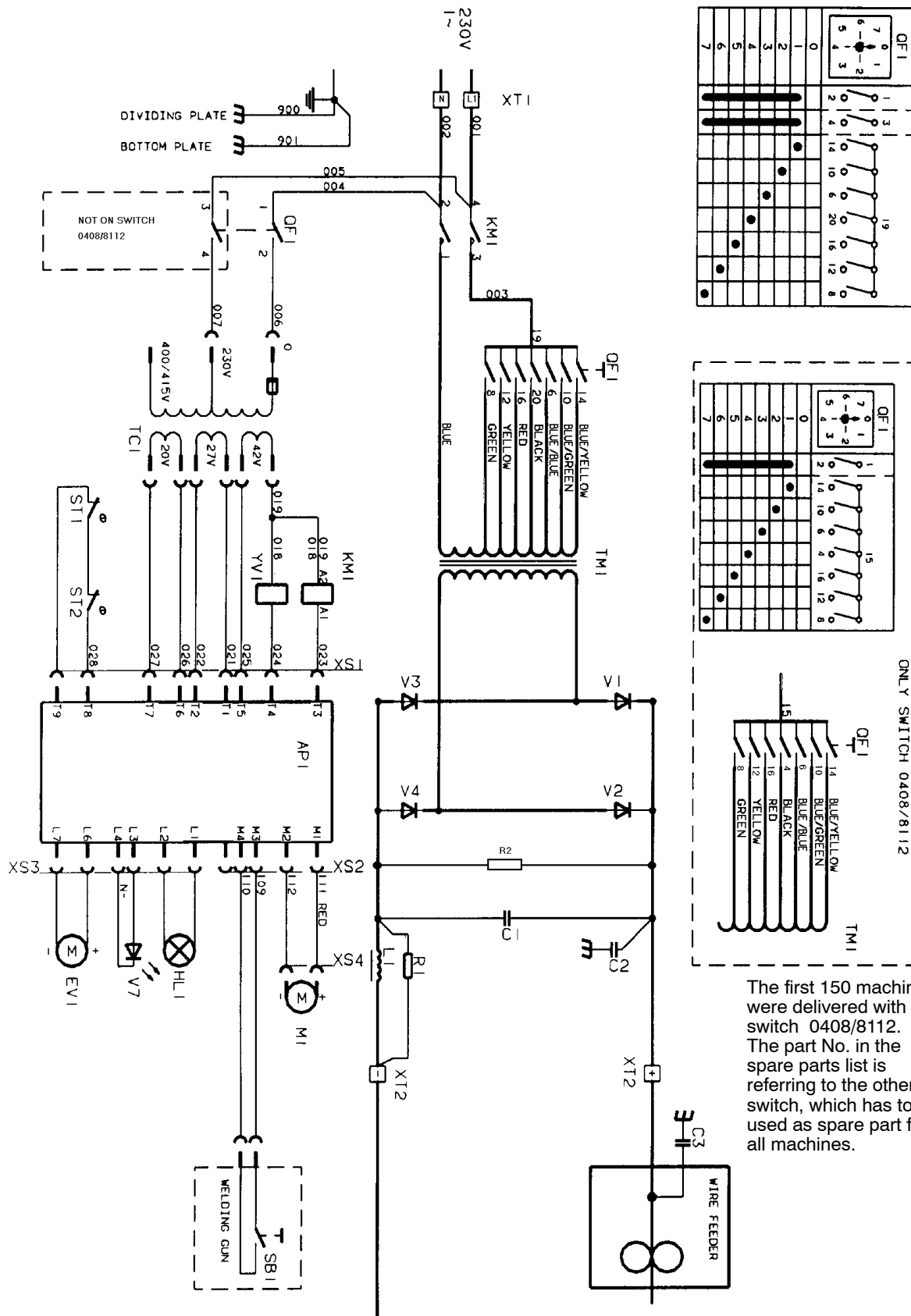

The first 150 machines were delivered with switch 0408/8112. The part No. in the spare parts list is referring to the other switch, which has to be used as spare part for all machines.

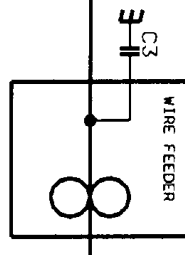

CONNECTION DIAGRAM, LKA 180 3-phase, 400 V

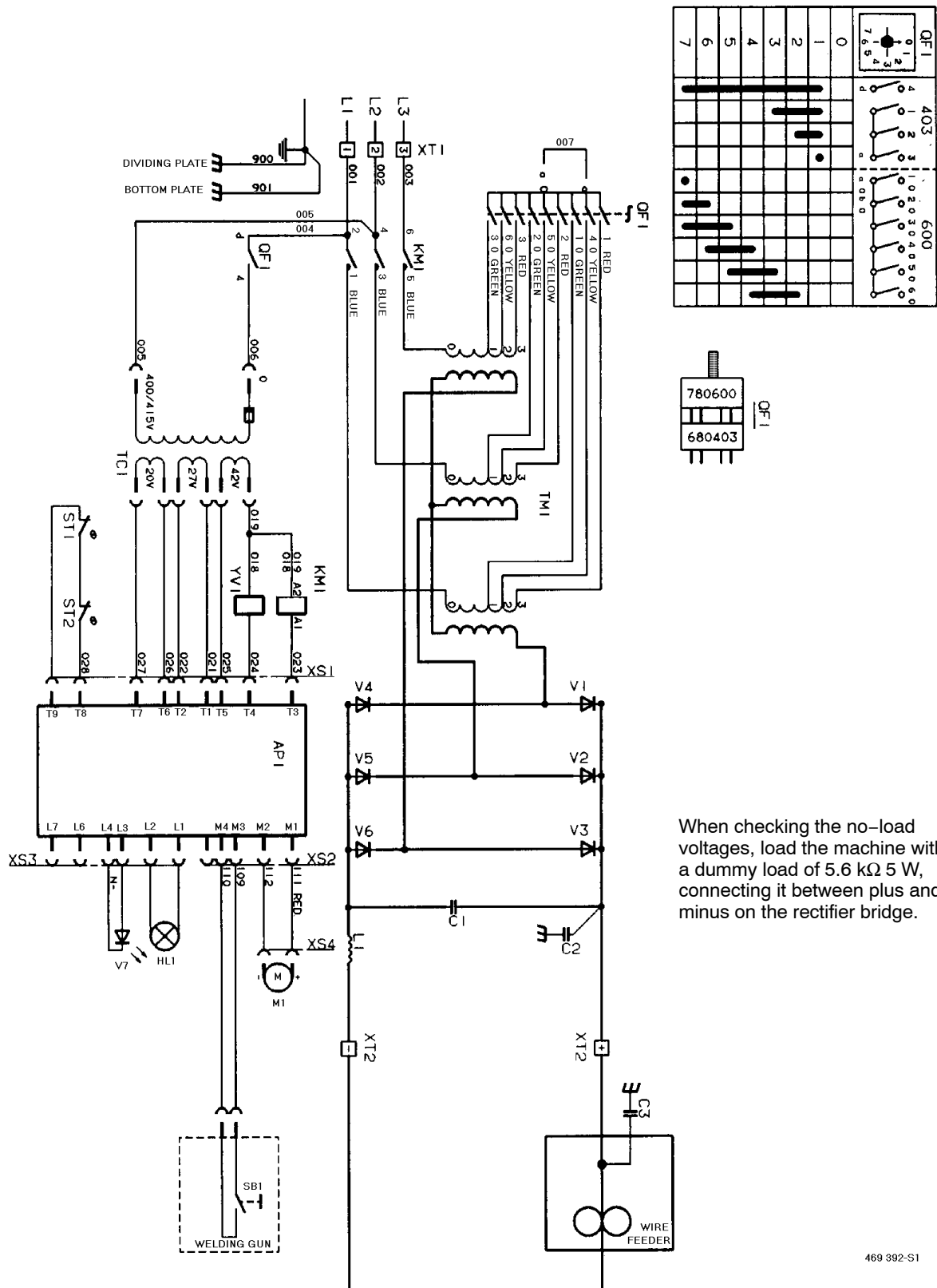

When checking the no-load voltages, load the machine with a dummy load of 5.6 kΩ 5 W, connecting it between plus and minus on the rectifier bridge.

469 392-S1

clka1e01

CONNECTION DIAGRAM, LKA 180 3-phase, 230/400 V

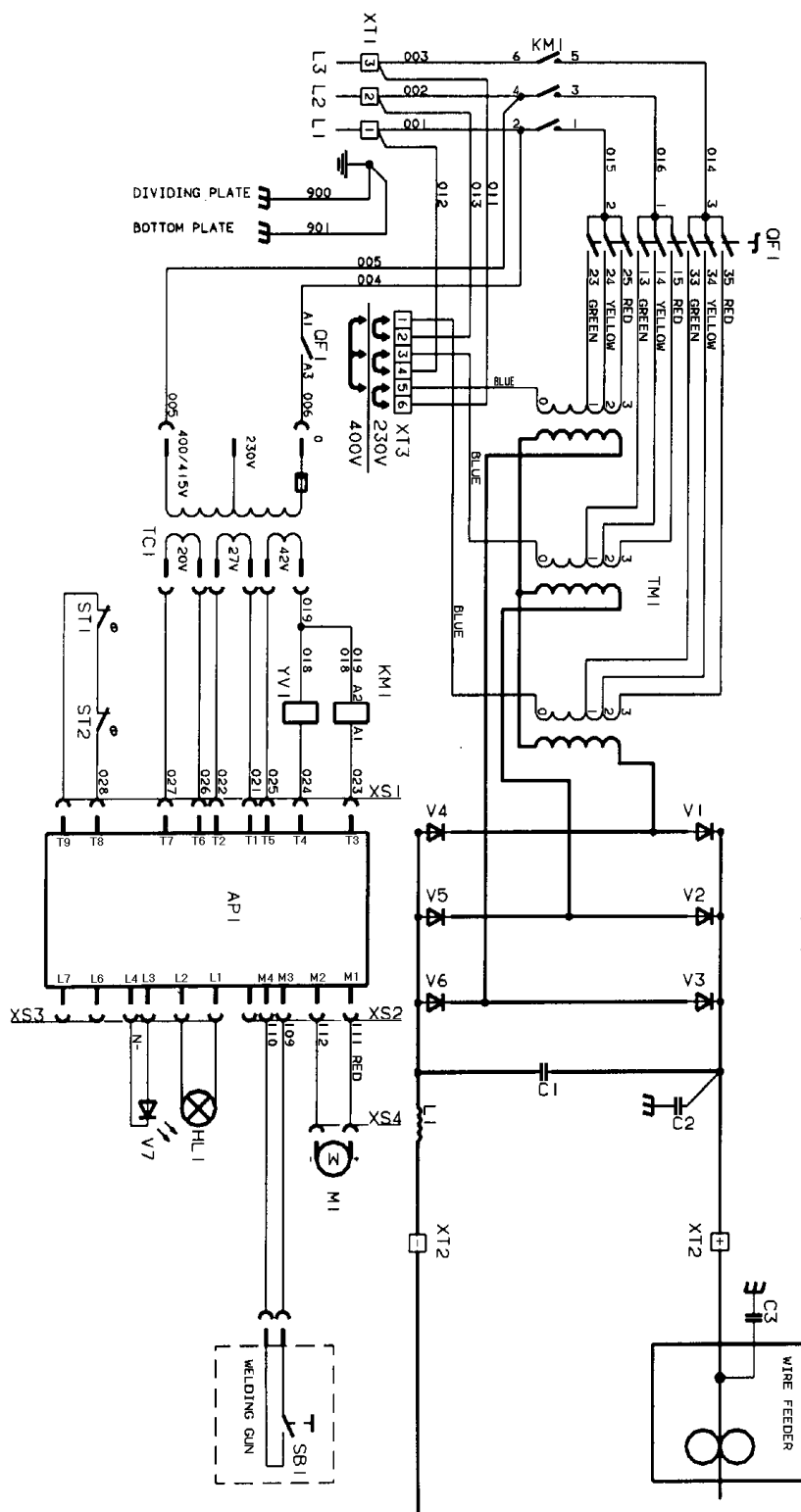

OF 1		A3	
0	1	A1	35
1	2	34	33
2	3	15	14
3	4	13	12
4	5	29	28
5	6	27	26
6	7	25	24
7		23	22

When checking the no-load voltages, load the machine with a dummy load of 5.6 kΩ 5 W, connecting it between plus and minus on the rectifier bridge.

469 557-S1
clka1e12

CONNECTION DIAGRAM, LKA 240 3-phase, 400 V

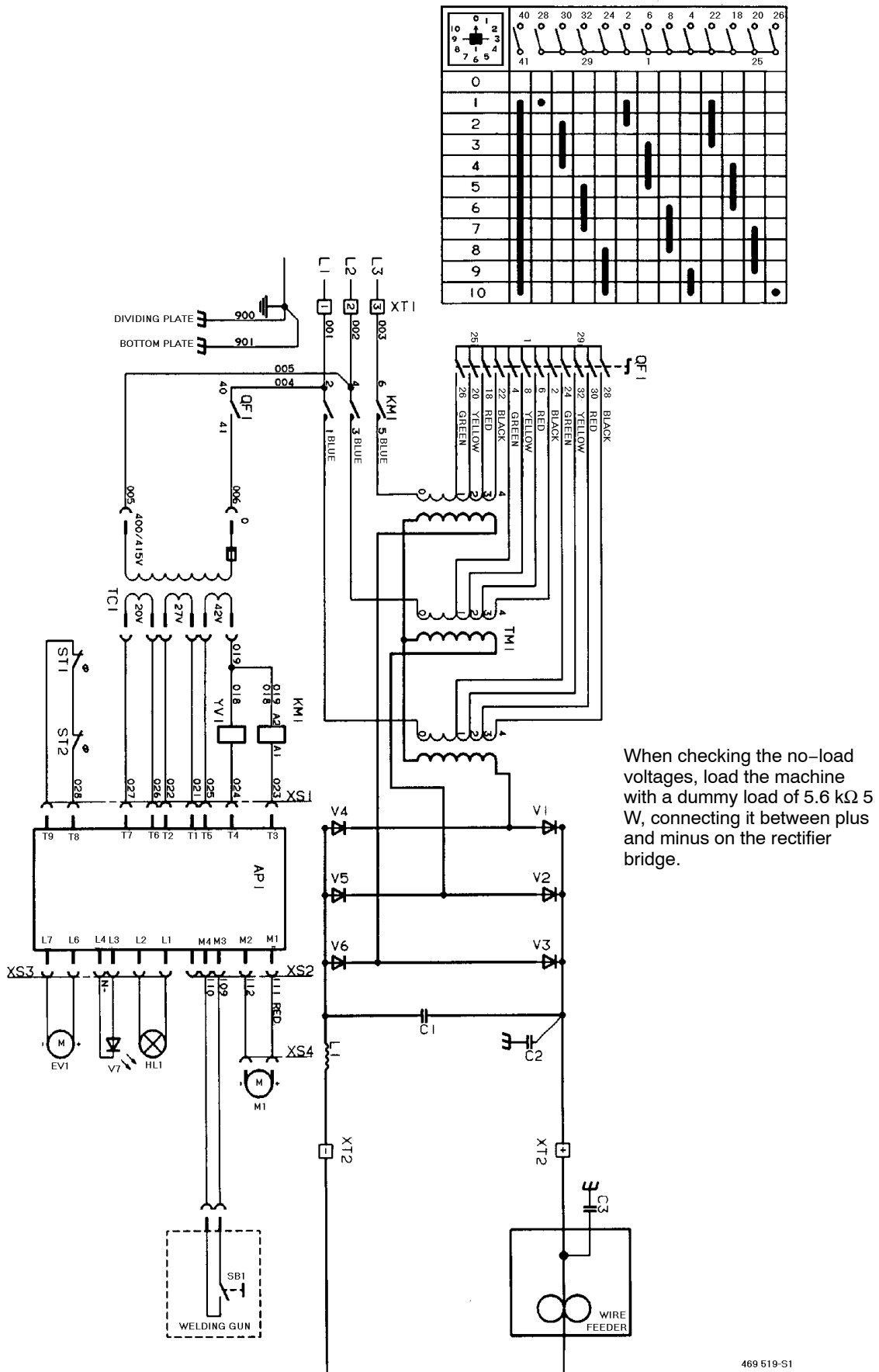

469 519-S1
clka1e02

CONNECTION DIAGRAM, LKA 240 3-phase, 230/400 V

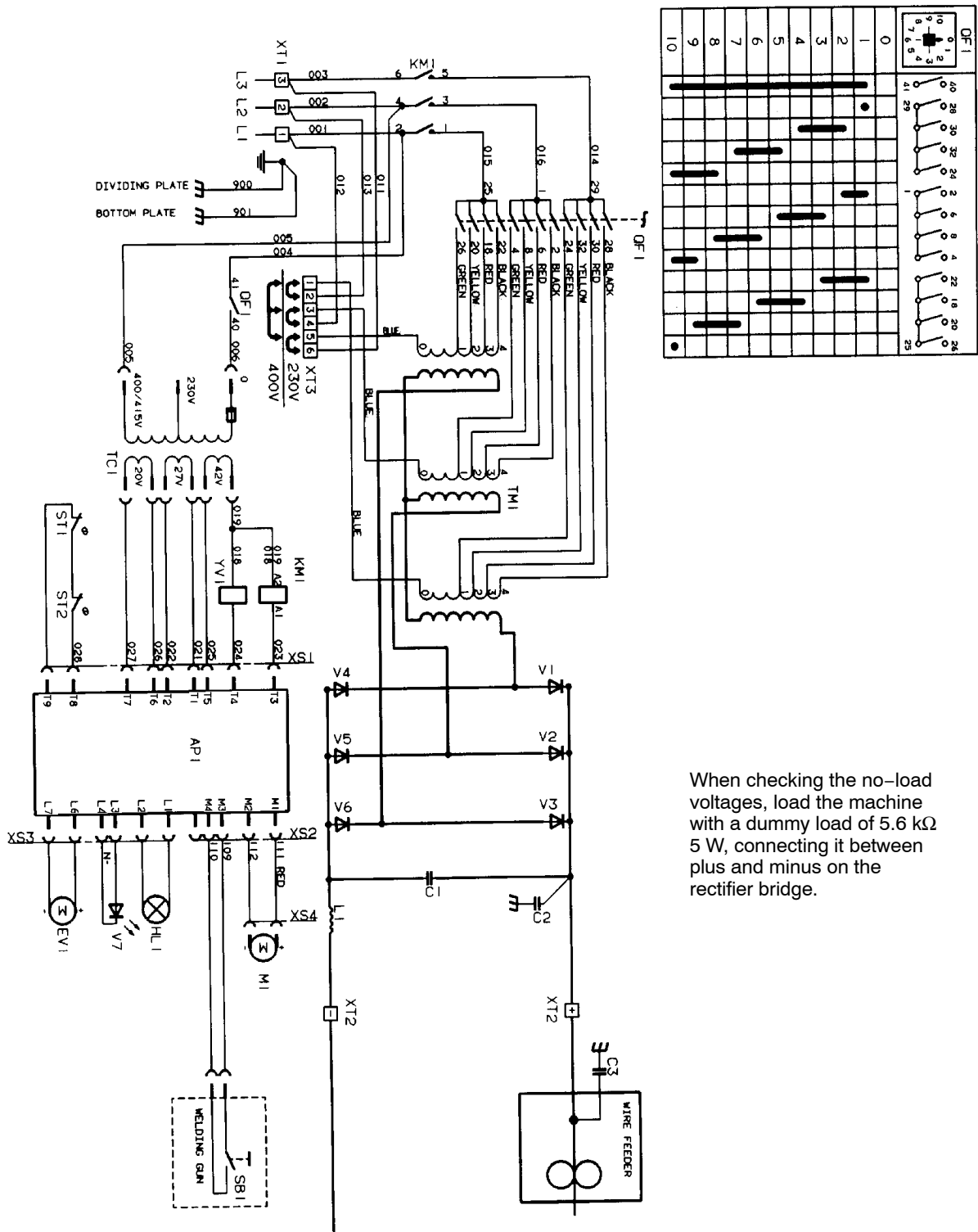

When checking the no-load voltages, load the machine with a dummy load of 5.6 kΩ 5 W, connecting it between plus and minus on the rectifier bridge.

469 558-S1
clka1e13

CIRCUIT DIAGRAM, CIRCUIT BOARD AP1

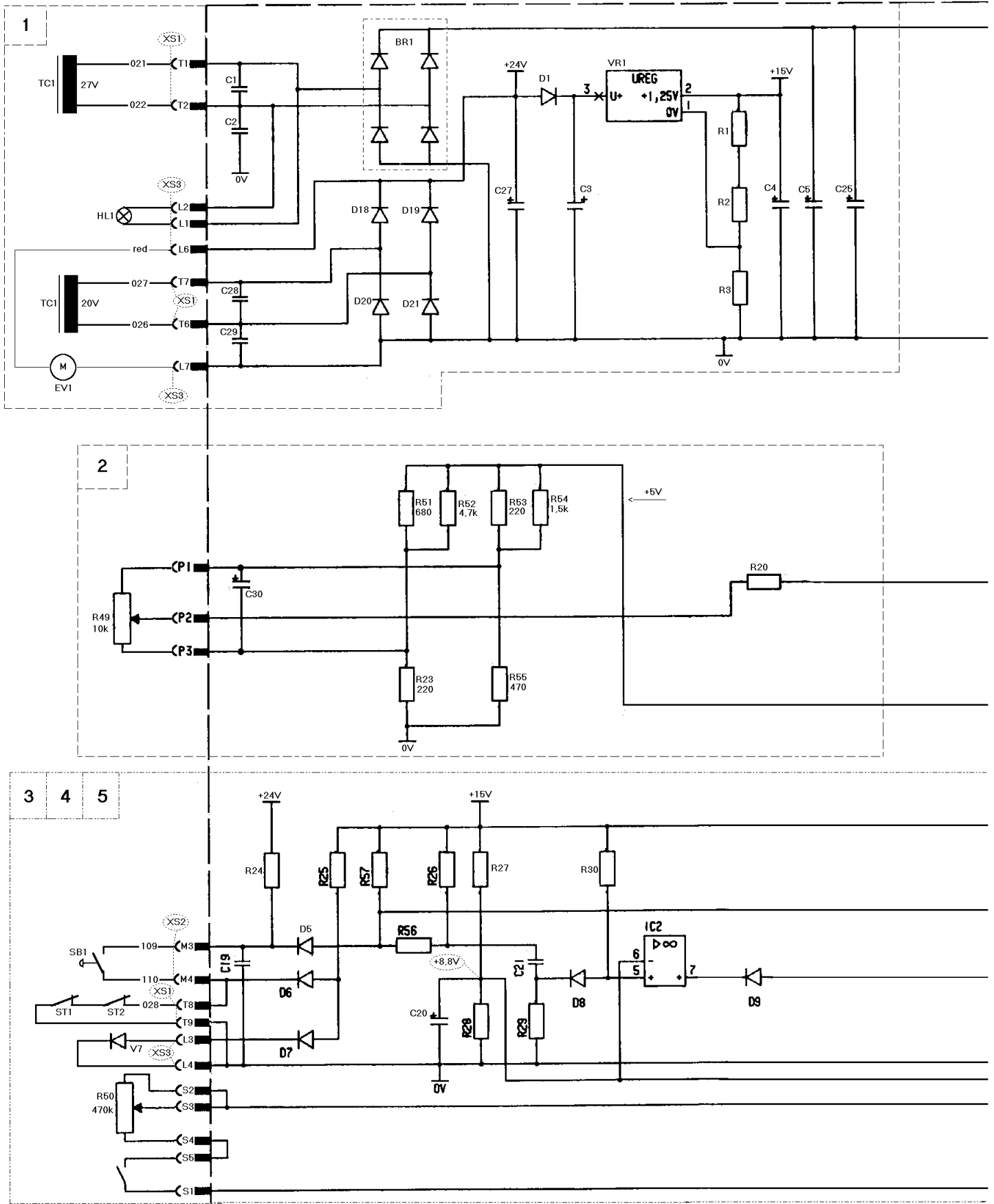

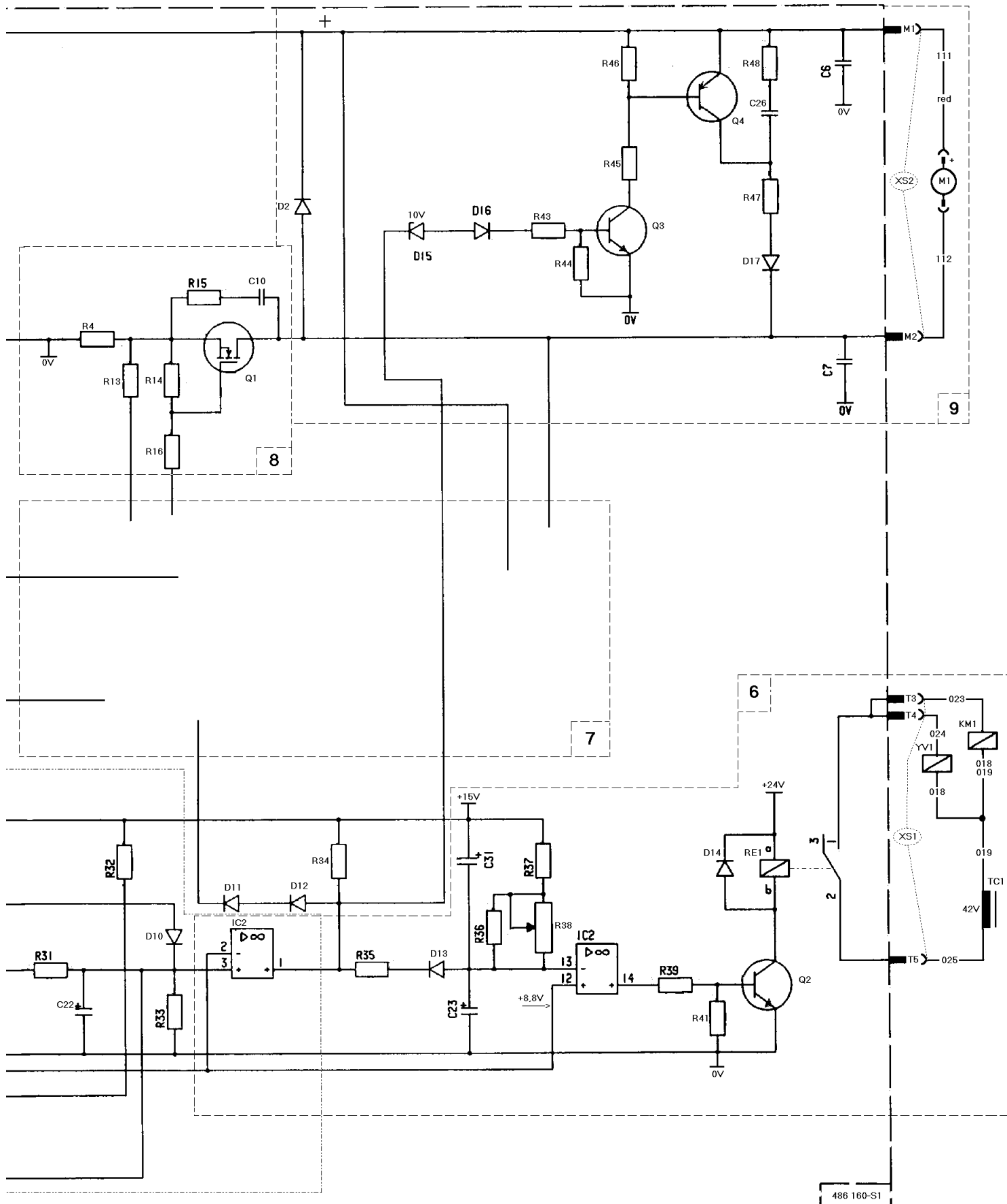

COMPONENT POSITIONS, CIRCUIT BOARD AP1

486 159-51

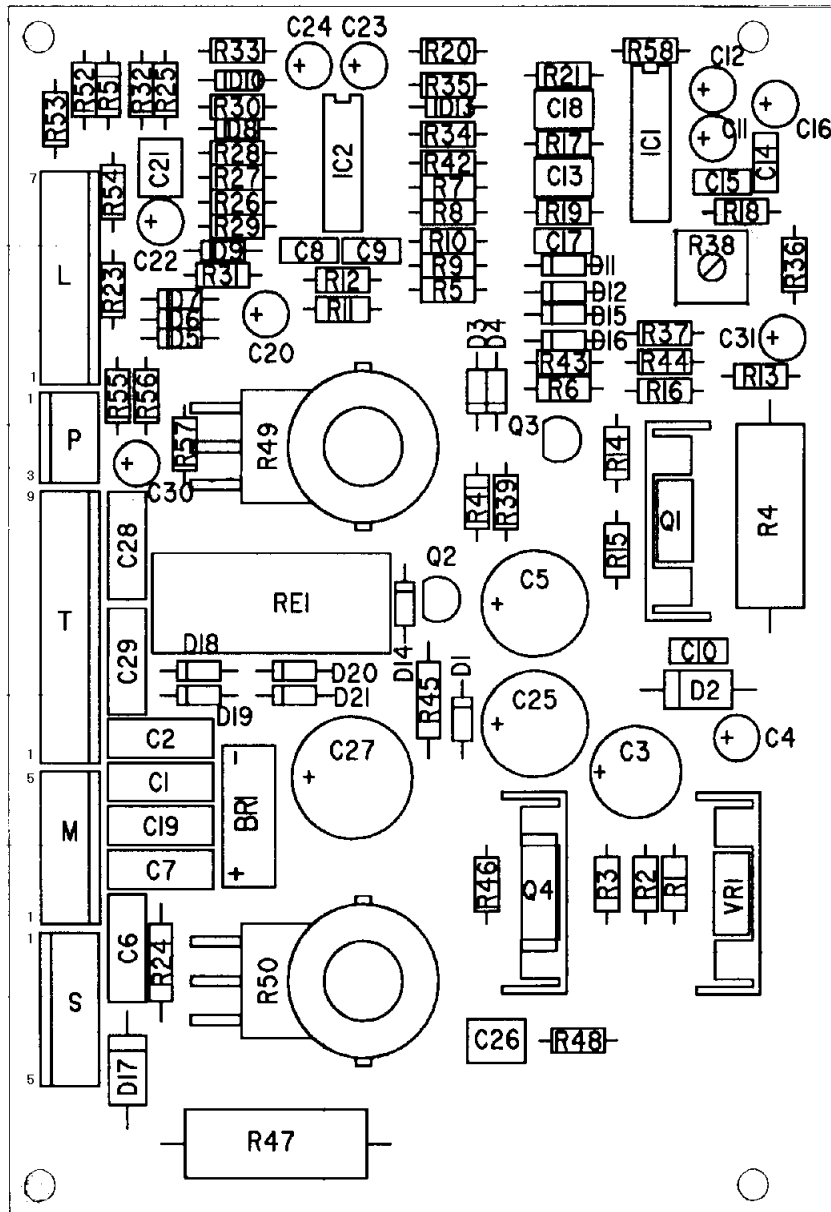

clka1e05

DESCRIPTION OF OPERATION, CIRCUIT BOARD AP1

This description relates to the circuit diagram on page 10 and to the component positions diagram on page 12.

Only those items connected to the inputs and outputs of the board are described here. If the board is faulty, it must be replaced.

1 POWER SUPPLY

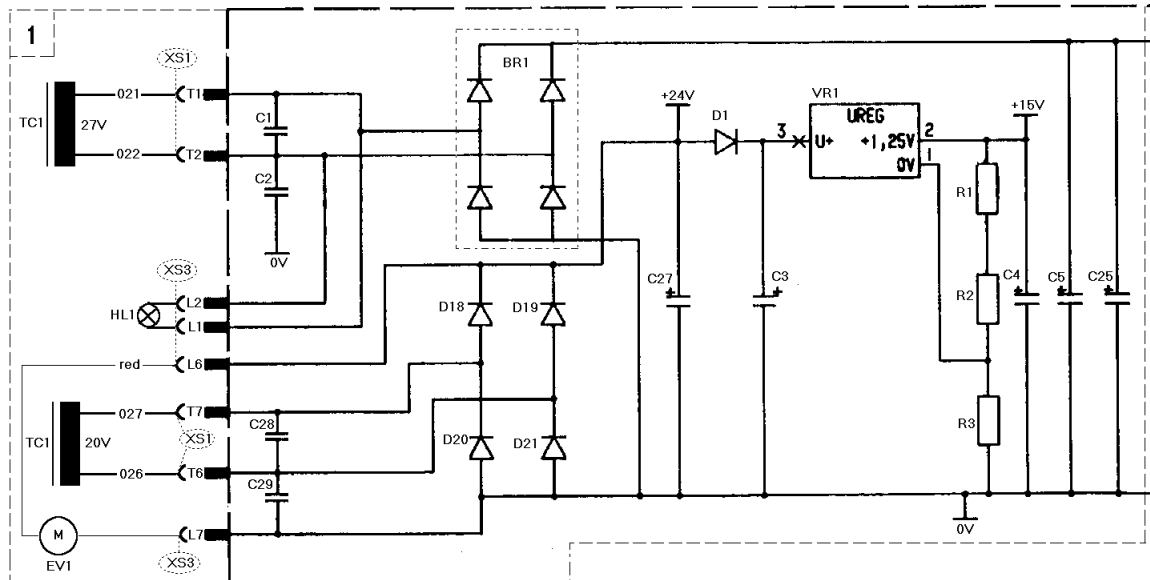

clka1e06

Transformer TC1 supplies indicating lamp HL1 and rectifier bridge BR1 with 27 V AC. The unsmoothed DC output from BR1 is smoothed by capacitors C5 and C25 to produce an open-circuit voltage of 38 V \pm 10%.

This provides the power supply for the wire feeder motor.

Connections T6 and T7 supply 20 V AC from transformer TC1 to diodes D18 – D21. The rectified voltage is about 24 V in the fan-cooled machines and somewhat higher in the 3-phase LKA 180. This supply powers fan EV1 in the fan-cooled machines.

Voltage regulator VR1 is supplied via diode D1 to provide a regulated 15 \pm 0.6 V supply.

2 REFERENCE CIRCUIT

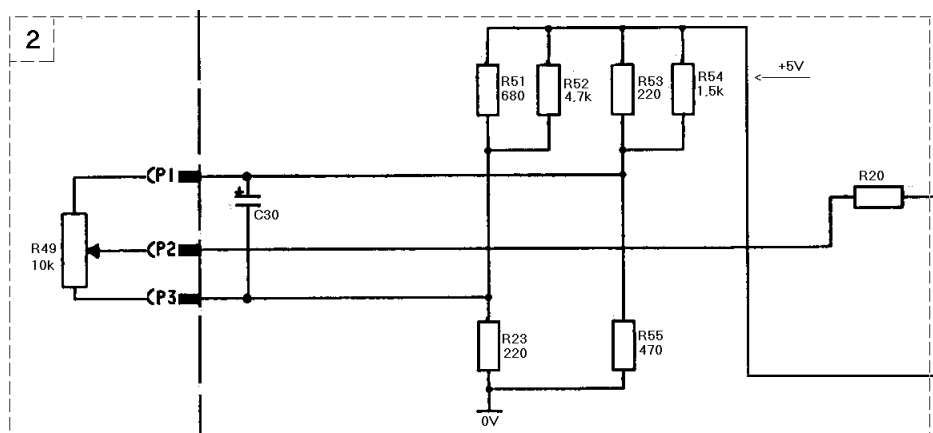

clka1e07

Potentiometer R49 controls the wire feed speed and is connected to terminals P1 – P3. It is energised via resistors R51 – R55 and R23. The reference voltage is supplied through resistor R20 to the error amplifier.

START/STOP CIRCUIT, THERMAL OVERLOAD CIRCUIT AND SPOT WELDING CIRCUIT

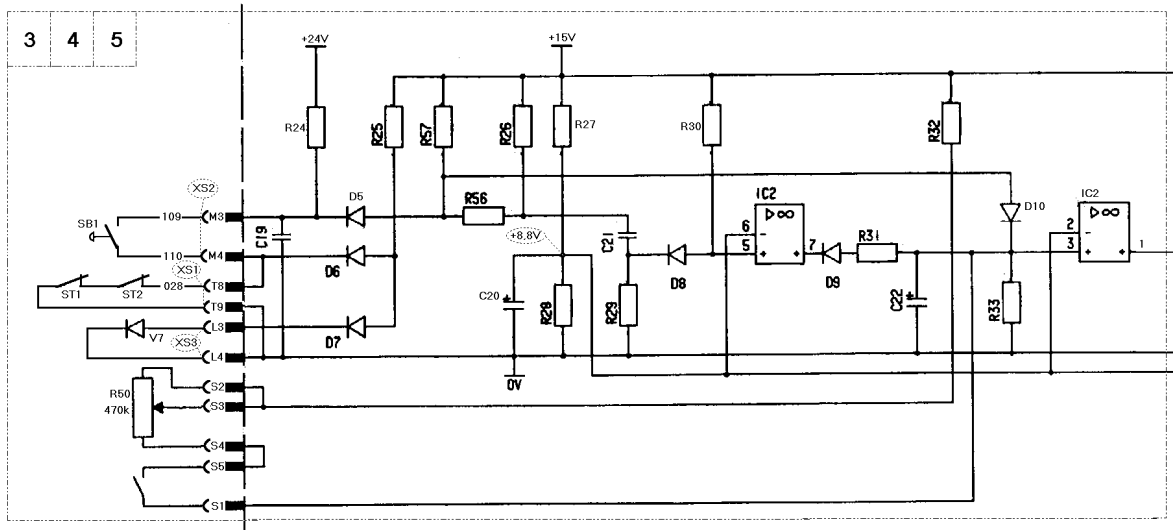

clka1e08

3 START AND STOP CIRCUIT

When the torch trigger switch SB1 is not activated, the voltage between M3 and M4 is 24 V. Pressing the trigger switch shorts the circuit, producing a voltage of 0 V between M3 and M4.

4 THERMAL OVERLOAD CIRCUIT

The machine contains two thermal overload cutouts, wired in series and connected to inputs T8 and T9. If either of them operates, the torch trigger switch circuit cannot be short-circuited, with the result that wire feed cannot be started.

When either of the thermal cutouts has operated, LED V7 is energised to indicate this via diode D7.

5 SPOT WELDING CIRCUIT

Potentiometer R50 controls the spot welding time and incorporates a switch. When in the zero position, the switch is open.

When the switch in R50 and torch trigger switch SB1 are closed, capacitor C22 charges up through resistors R32 and R50. Wire feed stops when the voltage on C22 reaches 8.8 V. The trigger switch must be released and then pressed again before a new spot weld can be made.

The spot welding time can be adjusted between 0.2 and 2.5 seconds $\pm 30\%$.

6 BURN-BACK TIME

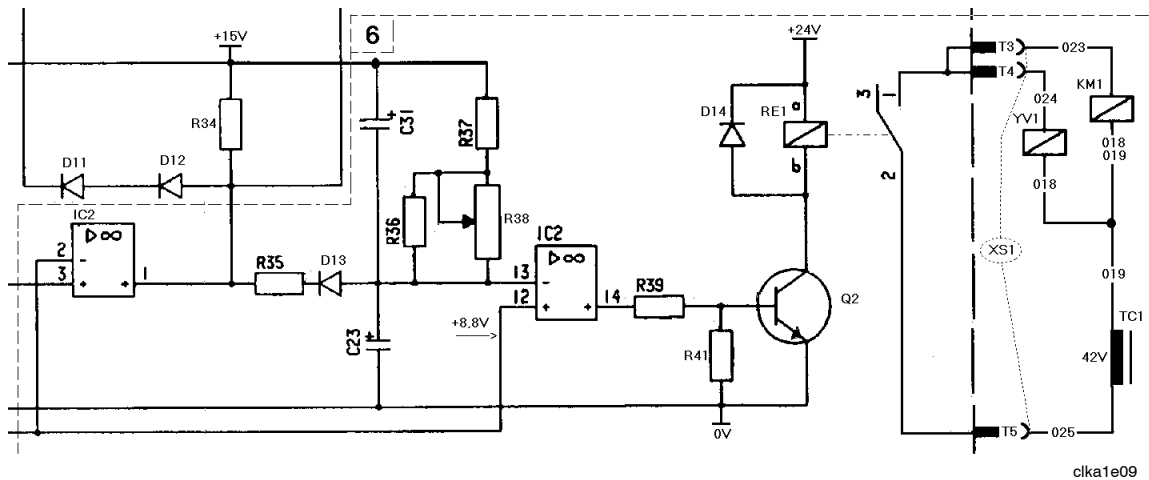

The burn-back time is the time from when wire feed ceases until contactor KM1 drops off.

During welding, the voltage at pin 13 of IC2 is low. The output of the inverter at pin 14 is therefore high, turning on transistor Q2 and activating relay RE1.

When the torch trigger switch is released, or when the spot welding time expires, capacitor C23 charges up via resistors R36, R37 and R38. When the voltage across C23 reaches 8.8 V, output 14 of IC2 goes low, turning off Q2 and causing relay RE1 to drop off.

Potentiometer R38 is used to adjust the burn-back time between 15 and 250 milliseconds. As delivered, the burn-back time is set to 170 milliseconds.

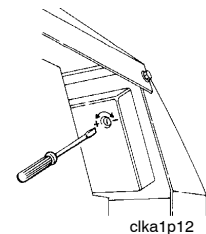

Adjusting the burn-back time

From machine number 618 R38 is not mounted, the burn-back time is not adjustable and set to 33 milliseconds with the resistors R36 and R37.

Spare part circuit boards to machines with earlier machine numbers are also having a none adjustable burn-back time, which is set to 65 milliseconds.

7 CONTROL AMPLIFIER AND PULSE WIDTH MODULATOR

The control amplifier compares the set value speed signal with the actual speed and supplies a control signal to the pulse width modulator. The actual value speed signal is provided by measuring the motor voltage.

The pulse width modulator controls the frequency and pulse time of current to the wire feed motor.

The switching frequency is about 2.5 kHz. The frequency is constant: it is the mark/space ratio that is varied.

MOTOR DRIVE AND BRAKING

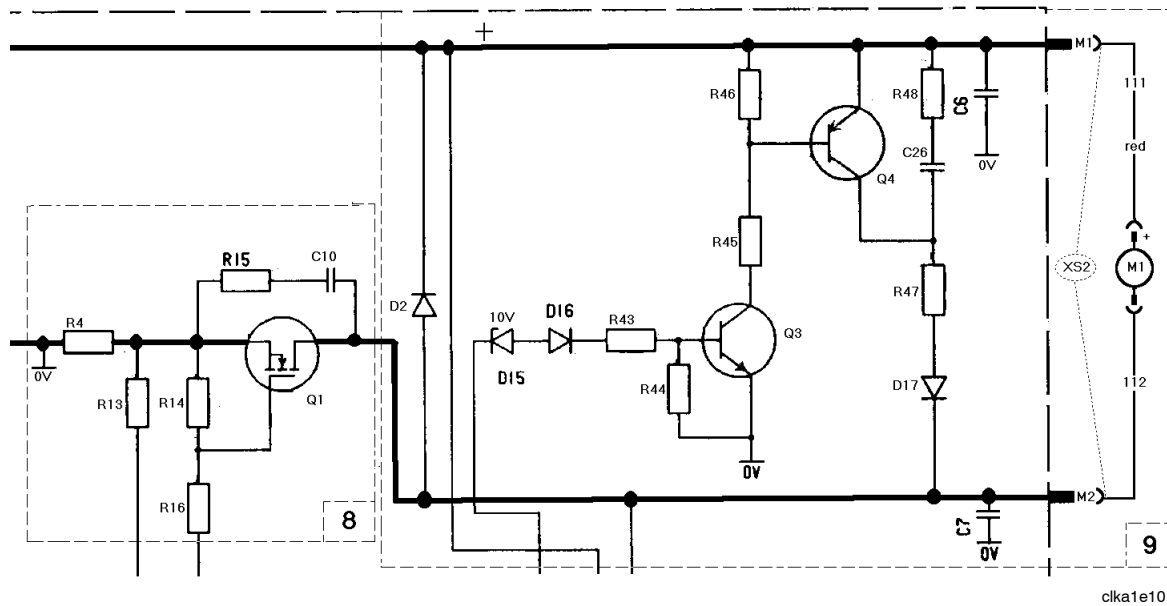

8 MOTOR DRIVE CIRCUIT

The output stage of the pulse width modulator is connected to transistor Q1 via resistor R16.

A motor current signal is provided by measuring the voltage across resistor R4, connected to transistor Q1.

If the voltage across R4 exceeds $1.1 \text{ V} \pm 60 \text{ mV}$, the gate pulses to Q1 are inhibited. This provides a current limit of about 11 A.

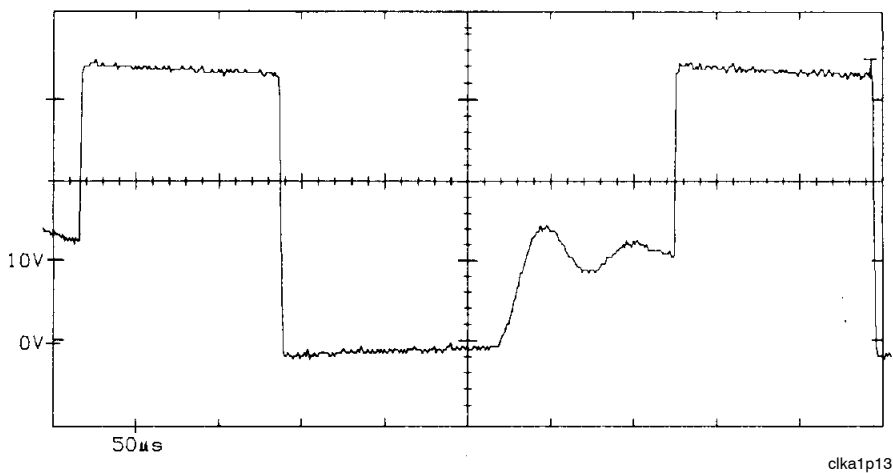

Motor voltage when the wire feed speed control potentiometer is in its centre position. The motor is unloaded.

9 BRAKING CIRCUIT

When wire feed is to stop, the pulse width modulator turns off the pulses to Q1. Transistors Q3 and Q4 turn on: transistor Q4 provides a path for dynamic braking current to flow through resistor R47 and diode D17.

LOAD CHARACTERISTICS

LKA 180 single phase

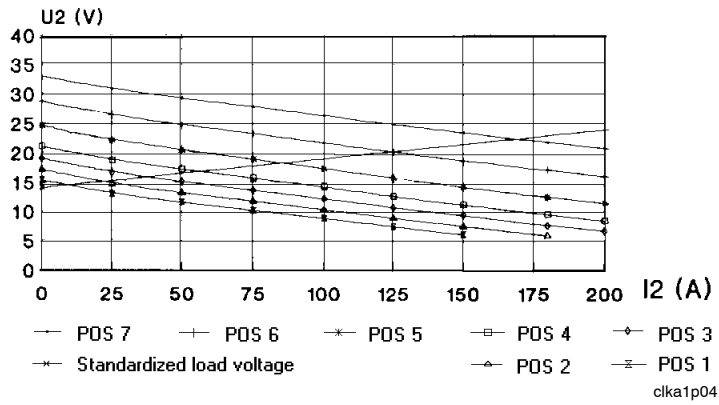

LKA 180 3-phase

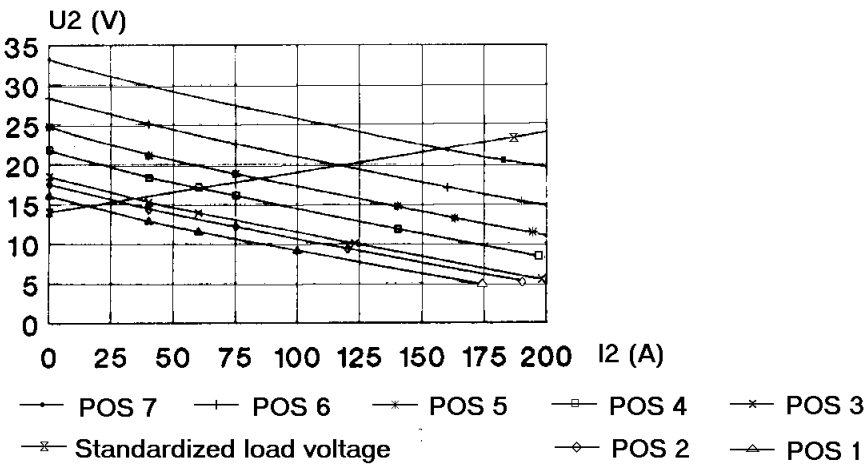

clka1p06

LKA 240

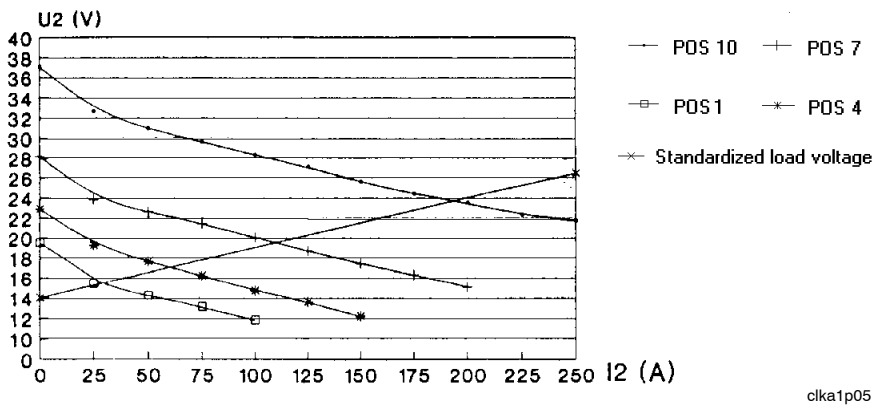

clka1p05

TECHNICAL DATA

	LKA 180 230V	LKA 180 400V	LKA 180 230/400V	LKA 240 400V	LKA 240 230/400V
Permissible loading At 10% duty cycle At 15% duty cycle At 60% duty cycle At 100% duty cycle	180A/19V 75A/19V 60A/17V	180A/19V 75A/18V 60A/17V	180A/19V 65A/20V;75/18 60A/17V;60/17	240A/22V 110A/19V 85A/18V	240A/22V 120A/20V;110/19 85A/19V;85/18
No-load voltage	16–33V	15–33V	15–33V	18–36V	18–36V
Voltage steps	7	7	7	10	10
Wire feed speed	1–15 m/min	1–15 m/min	1–15 m/min	1–15 m/min	1–15 m/min
Spot welding time	0.25–2.5 s	0.25–2.5 s	0.25–2.5 s	0.25–2.5 s	0.25–2.5 s
Wire drum capacity	5–15 kg	5–15 kg	5–15 kg	5–15 kg	5–15 kg
Wire sizes Non–alloyed steel Stainless steel Aluminium Gasless filler wire	0.6–0.8 mm 0.6–0.8 mm 1.0 mm 0.8–0.9 mm	0.6–0.8 mm 0.6–0.8 mm 1.0 mm 0.8–0.9 mm	0.6–0.8 mm 0.6–0.8 mm 1.0 mm 0.8–0.9 mm	0.6–0.8 mm 0.6–0.8 mm 1.0 mm 0.8–0.9 mm	0.6–0.8 mm 0.6–0.8 mm 1.0 mm 0.8–0.9 mm
Power supply	230V 50Hz 1–phase	400V 50Hz 3–phase	230/400V 50Hz 3–phase	400V 50Hz 3–phase	230/400V 50Hz 3–phase
Maximum primary current	30A	9A	16/9A	11A	19/11A
Mains fuse rating	20A slow–blow	10A slow–blow	10/10A slow–blow	10A slow–blow	16/10A slow–blow
Mains cable, area	3x2.5 mm ²	4x1.5 mm ²	4x2.5 mm ²	4x1.5 mm ²	4x2.5 mm ²
Weight	53 kg	53 kg	53 kg	56 kg	56 kg
Enclosure class	IP21S	IP21	IP21	IP21	IP21
Application class	S	S	S	S	S

The **S** symbol indicates that the machine has been designed and built for use in areas of elevated electrical risk.

IP21 indicates the enclosure class in respect of protection against penetrating objects and water. Enclosure class IP21 indicates that the equipment is intended for indoor use, while IP23 equipment is also suitable for outdoor use.

Main dimensions, LKA 180 and LKA 240

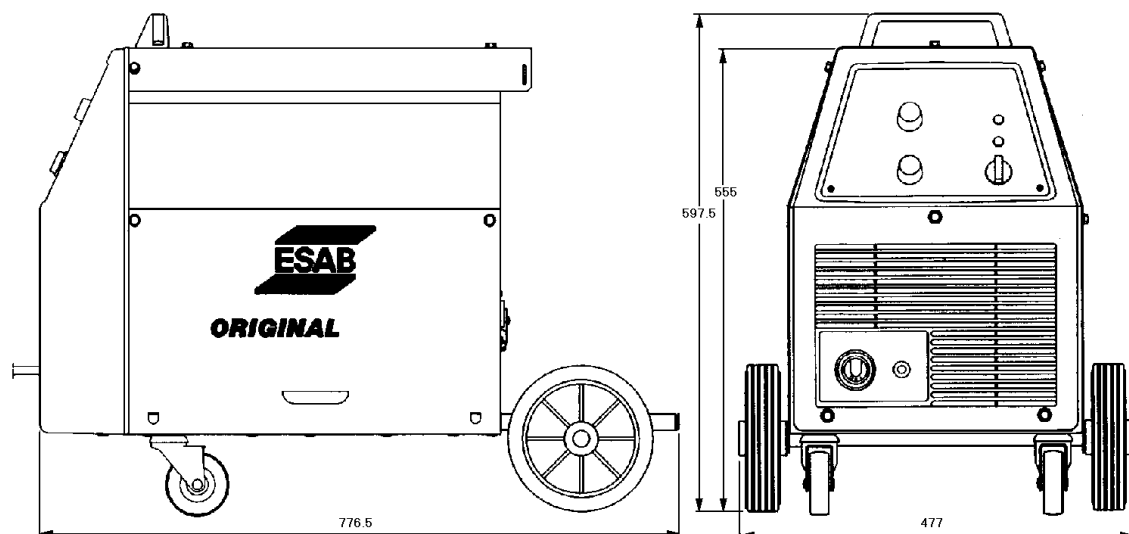

clka1p08

INSTALLATION

- Place the machine in a suitable position and check that cooling is not obstructed.
- Check that the machine is connected to suit the mains supply voltage. In the machines that can be connected for different supply voltages, make the appropriate connections as required at terminal block XT3 and transformer TC1. Make the necessary earth connections in accordance with safety regulations.

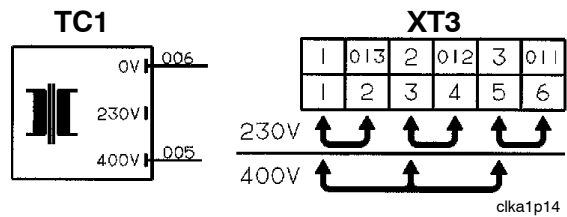

- Fit the filler wire as shown below.

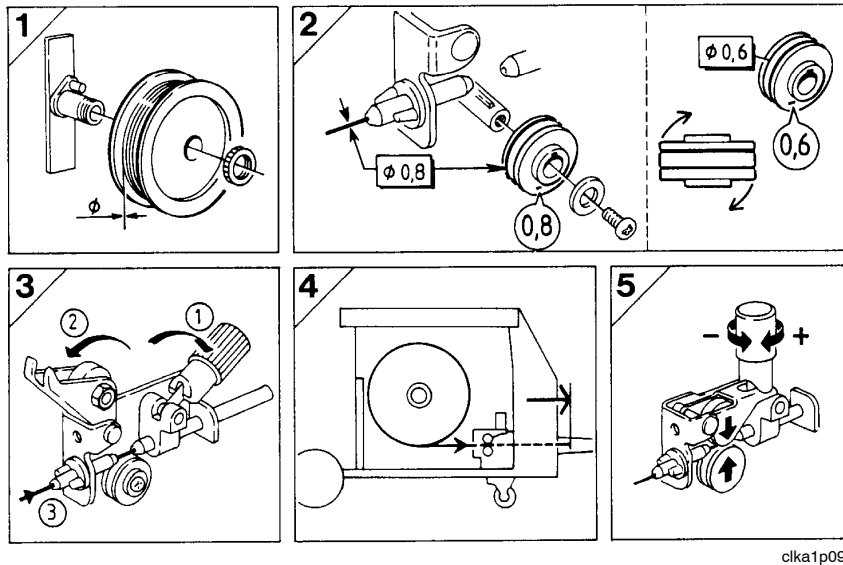

The picture above is valid for machines with serial numbers before 618

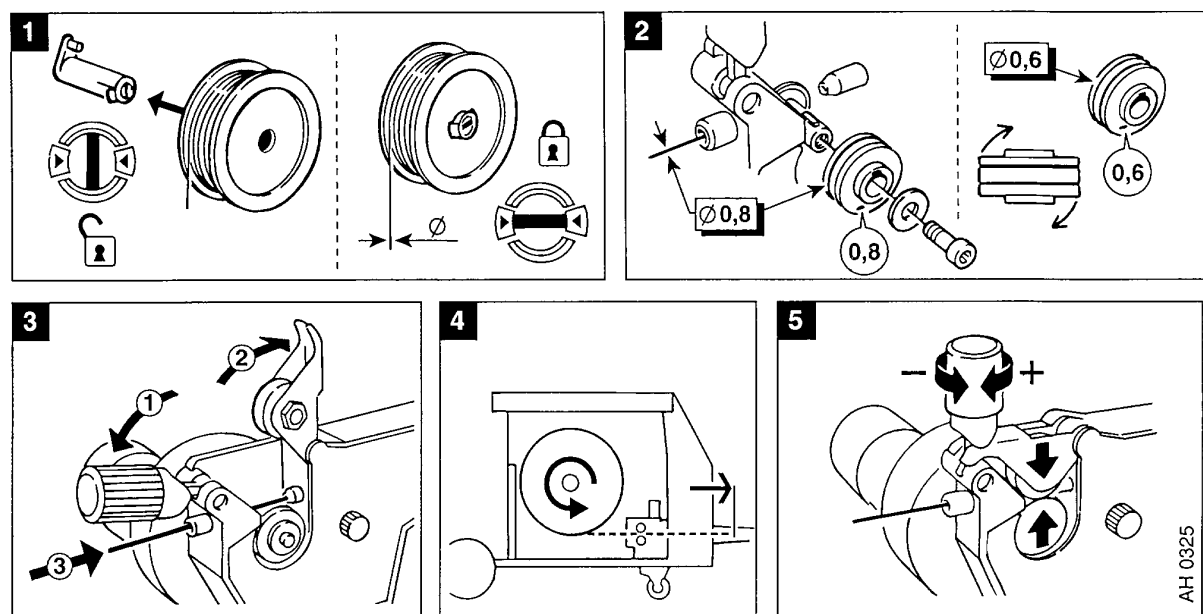

The picture above is valid from serial number 618

If the drive rollers slip or wire feed does not work properly, it may be necessary to adjust the roller pressure, as shown in Figure 5 above.

GASLESS WIRE

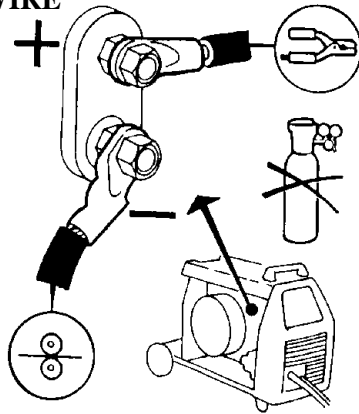

SOLID WIRE

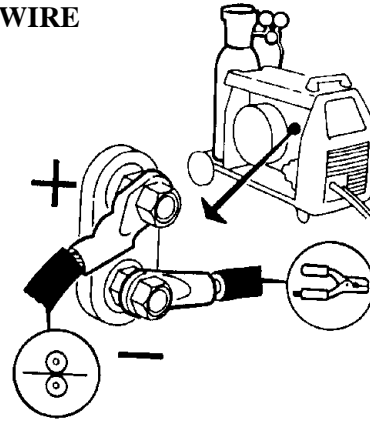

clka0p10

When welding with gasless wire, the return current cable must be connected to the positive terminal on the terminal block above the wire feed unit.

OPERATION

- Connect the return current conductor clamp (E) to the workpiece.
- When welding with solid wire, open the gas valve (A) on the gas bottle and adjust the gas flow by reducer valve (B). The gas flow must be 8 – 12 litres per minute.
- Turn on the power unit and set a suitable voltage with knob (L). The white indicating lamp (K) must be lit.
- Hold the welding torch trigger switch (D) pressed until filler wire is fed out through the contact tip (F).
- Select suitable welding data with the voltage control selector (L) and the wire feed control knob (H), as shown in the tables on page 21 – 23.
- Start welding. Adjust the settings if necessary.
- The yellow LED (J) on the front panel will light if the thermal overload cutout operates as a result of overload. The overload cutout resets automatically when the machine has cooled to a safe temperature.

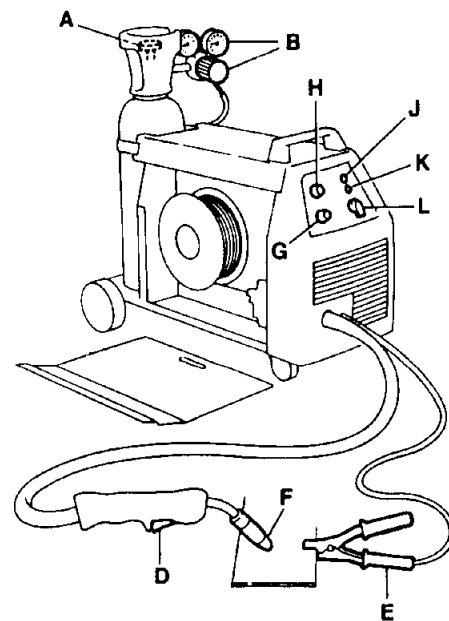

clka1p11

Spot welding

Set potentiometer (G) to a suitable spot welding time: the time range is steplessly adjustable from 0.2 to 2.5 seconds. The scale is graduated from 1 to 10. Press the torch trigger switch. When the preset welding time is up, welding will be stopped without the operator having to release the trigger switch. Release the trigger switch and press it again to start a new welding sequence.

MAINTENANCE

- **Cleaning away dust**

Blow the unit clean with compressed air at reduced pressure.

- **Wire feed mechanism.**

The wire feed mechanism should be cleaned, and wearing parts replaced, at regular intervals in order to ensure smooth, reliable wire feed.







Do not tension the pressure roller too hard, as this will result in abnormal wear to the pressure roller, the feed roller and the wire guide.

- **Welding torch.**

Blow the wire guide clean and clean the gas nozzle at regular intervals.

WELDING DATA SELECTION



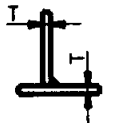
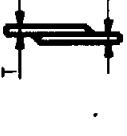
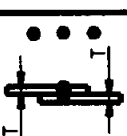
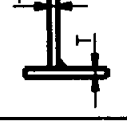



MACHINE SETTINGS, LKA 180 single-phase

LKA 180 ~		T mm	TRÁD WIRE DRAHT FIL	MIX			CO ₂			T			
						t			t			t	
Fe		0.6	Fe 0.8	2,5	2					2,5	1		
			Gl 0.8										
		0.8	Fe 0.6	4,5	4								
			Fe 0.8	3	3								
		1.0	Fe 0.6	7	5								
			Fe 0.8	3,5	4		3	4			3	2	
	1.5	Fe 0.8	10	6									
		Gl 0.8	5	5		4	5			3,5	3		
	2.0	Fe 0.6											
		Fe 0.8	7	6		6	6						
	3.0	Gl 0.8								5	4		
		Fe 0.8	9,5	7		8	7			7	5		
			0.6	Fe 0.8	5,5	5	3,5				5	5	3
				Gl 0.8									
0.8			Fe 0.8	5,5	5	5,5							
			Gl 0.8										
1.0			Fe 0.8	5,5	5	7							
1.5	Fe 0.8	7,5	7	7									
Al			Ar										
			1.0	Al 1.0	4,5	2							
			1.5	Al 1.0	5	3							
			2.0	Al 1.0	5,5	4							
			3.0	Al 1.0	6	6							
4.0	Al 1.0	8	7										
Ss			Ar+O ₂										
			1.0	Ss 0.8	3,5	2							
			1.5	Ss 0.8	5,5	5							
			2.0	Ss 0.8	7	6							
3.0	Ss 0.8	10	7										

455 019-001

clka1p15



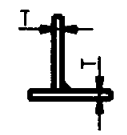
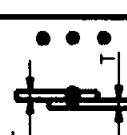
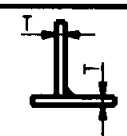
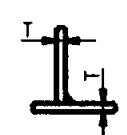



MACHINE SETTINGS, LKA 180 3-phase

LKA 180		T mm	TRAD WIRE DRAHT FIL	MIX			CO ₂			Ar		
						t			t			t
Fe		0.6	F 0.6	3	2							
			F 0.8	2,5	2							
			GL 0.8						2,5	1		
		0.8	F 0.6	3,5	3		3,5	4				
			F 0.8	2,5	2		3	4				
			GL 0.8						2,5	2		
	1.0	F 0.6	4	4		4,5	5					
		F 0.8	3	3		3	4					
		GL 0.8						3	2			
	1.5	F 0.6	5,5	5		8	6					
		F 0.8	3,5	4		3,5	5					
		GL 0.8						3	3			
	2.0	F 0.6	6,5	5		10	7					
		F 0.8	4,5	5		5,5	6					
		GL 0.8						3,5	5			
	3.0	F 0.6	9	6								
		F 0.8	6,5	6		7	7					
		GL 0.8						6	6			
4.0	F 0.8	9	7									
	GL 0.8						10	7				
		0.6	F 0.8	10	7	1,5						
			GL 0.8						10	7	2	
		0.8	F 0.8	10	7	2,5						
			GL 0.8						10	7	3,5	
		1.0	F 0.8	10	7	3,5						
			GL 0.8						10	7	8	
1.5	F 0.8	10	7	8,5								
Al		Ar										
		1.0	Al 1.0	5	2							
		1.5	Al 1.0	7	4							
		2.0	Al 1.0	7	5							
		3.0	Al 1.0	8,5	6							
4.0	Al 1.0	10	7									
Ss		Ar + O₂										
		1.0	Ss 0.6	6,5	4							
			Ss 0.8	4	4							
			Ss 1.0	3,5	3							
		1.5	Ss 0.6	9	5							
			Ss 0.8	5,5	5							
			Ss 1.0	3,5	4							
		2.0	Ss 0.8	9	6							
			Ss 1.0	5,5	5							
		3.0	Ss 0.8	10	7							
Ss 1.0	6,5		7									
4.0	Ss 1.0	7	7									

469 448-001

clka1p16

MACHINE SETTINGS, LKA 240

LKA 240	T mm	TRAD WIRE DRAHT FIL	MIX			CO ₂			T			
					t			t			t	
Fe	0.6	F _e 0.6	3	1								
		F _e 0.8	2.5	1								
		Gl 0.8										
	0.8	F _e 0.6	3.5	2		3	3					
		F _e 0.8	3	1		2.5	3					
		F _e 1.0	2.5	1		2.5	4		2.5	1		
	1.0	Gl 0.8										
		F _e 0.6	4	3		3.5	4					
		F _e 0.8	3	2		2.5	4					
	1.5	F _e 1.0	2.5	1		2.5	4					
		Gl 0.8							2.5	1		
		F _e 0.6	5.5	4		4.5	5					
	2.0	F _e 0.8	3.5	3		3	5					
		F _e 1.0	3	3		3	5					
		Gl 0.8							3	3		
	3.0	F _e 0.6	7.5	6		6	7					
		F _e 0.8	4.5	5		3.5	6					
		F _e 1.0	4	5		3.5	6		4	5		
	4.0	Gl 0.8										
		F _e 0.6	10	7		8	8					
		F _e 0.8	6.5	7		4.5	7					
	Al	0.6	F _e 1.0	6	8		4	7		5.5	7	
			Gl 0.8									
			F _e 0.8	9.5	9		6	8				
0.8		F _e 1.0	8	10		5.5	9		8.5	9		
		Gl 0.8										
		F _e 0.8	7	9	2.5				8	8	2	
1.0		Gl 0.8										
		F _e 0.8	7	9	4				8	8	3.5	
		Gl 0.8										
1.5		F _e 0.8	7	9	6				8	8	6	
		Gl 0.8										
		F _e 0.8	8	10	8.5							
Ar												
		1.5 Al 1.0	7	2								
		2.0 Al 1.0	8	4								
Ss		1.0	3.0 Al 1.0	9	7							
		1.5	Ar+O₂									
			S _s 0.6	7	4							
			S _s 0.8	6	5							
		2.0	S _s 1.0	3.5	2							
			S _s 0.6	10	6							
			S _s 0.8	7.5	7							
	3.0	S _s 1.0	4.5	4								
		S _s 0.8	9	8								
		S _s 1.0	7	6								
4.0	S _s 0.8	10	10									
	S _s 1.0	8	9									
	S _s 1.0	8.5	10									

469 455-001

clka1p17

SPARE PARTS LIST LKA 180/240

Edition 040928

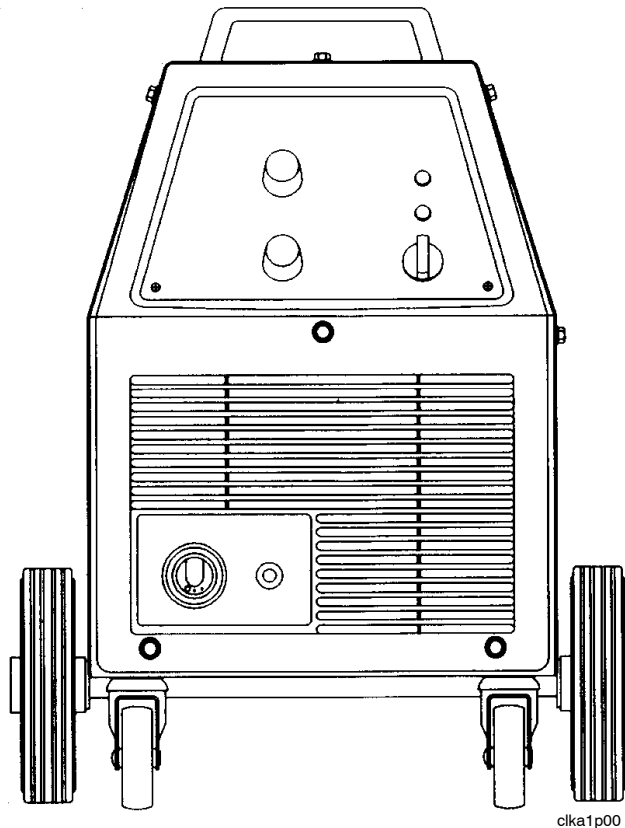

Ordering no.	Denomination	Notes
469 440-880	LKA 180	400 V 3 phase
469 565-880	LKA 180	230/400 V reconnectable, 3 phase
469 560-880	LKA 180	230 V single-phase
469 560-881	LKA 180	230 V single-phase, only for the Australian market. Position 102 deviates from version 469 560-880
469 450-880	LKA 240	400 V 3 phase
469 570-880	LKA 240	230/400 V reconnectable, 3 phase
469 560-881	LKA 180	230 V single-phase, only for the Australian market. Position 102 deviates from version 469 560-880
469 450-882	LKA 240	400 V 3 phase, only for the Australian market. Position 102 deviates from version 469 560-880

Spare parts list - Reservdelsförteckning - Ersatzteilverzeichnis - Liste de pièces détachées

Spare parts are to be ordered through the nearest ESAB agency as per the list on the back of the cover. Kindly indicate type of unit, serial number, denominations and ordering numbers according to the spare parts list.

Reservdelar beställs genom närmaste ESAB-representant, se sista sidan. Vid beställning var vänlig uppgi typ och tillverkningsnummer samt benämningar och beställningsnummer enligt reservdelsförteckningen.

Die Ersatzteile können bei der nächsten ESAB-Vertretung bestellt werden, siehe letzte Seite. Bitte geben Sie Typenbezeichnung und Herstellungsnummer sowie Bezeichnungen und Bestellnummern laut Ersatzteilverzeichnis an.

Au dos de la brochure, vous trouverez l'adresse du représentant ESAB le plus proche. Prière de lui adresser votre commande, après avoir pris le soin de mentionner le type et le numéro de série de l'unité ainsi que le numéro de commande et la désignation conformément à la liste de pièces détachées.

180 = LKA 180 240 = LKA 240

C = component designation in the circuit diagram

Item no.	Qty 180	Qty 240	Ordering no.	Denomination	Notes	C
101	1	1	469 368-001	Cover plate		
102	1	1	469 369-001	Rear panel		
	1	1	469 664-001	Rear panel	Only for the Australian market	
103	1	1	469 447-001	Side panel	With text	
104	1	1	0700 200 002	Welding gun MXL 200		
107	1	-	0469 572 881	Return cable	Complete	
	-	1	0469 443 880	Return cable	Complete	
109	1	1	469 361-001	Front panel		
110	2	2	469 468-001	Link wheel		
	8	8		Screw	M6 x 16 mm	
111	1	1	368 265-001	Securing strap		
120	2	2	469 453-001	Attachment		
121	1	1	469 516-001	Shaft		
122	2	2		Washer	D 21/36	
123	2	2	469 469-001	Wheel		
124	2	2	192 859-126	Locking washer		
125b	1	1	146 967-881	Brake hub	From machine no. 547 612	
126	1	1	469 437-001	Handle		
	2	2		Screw	M6 x 16mm	

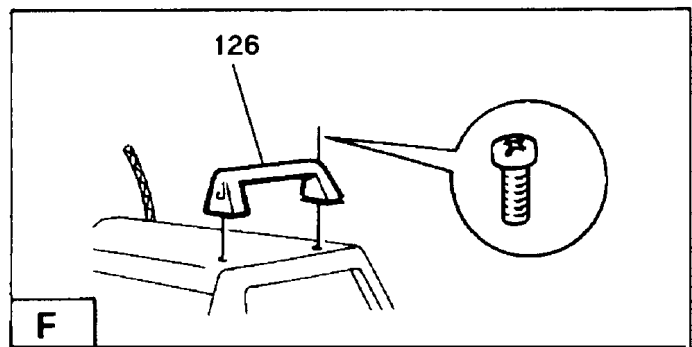
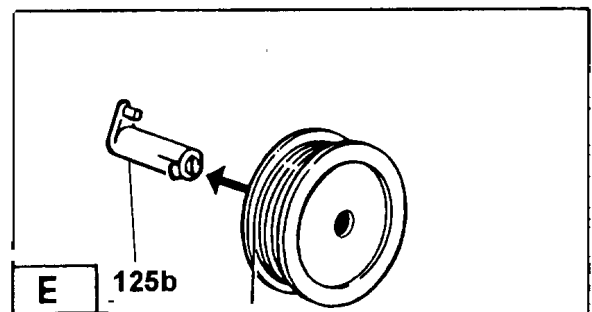
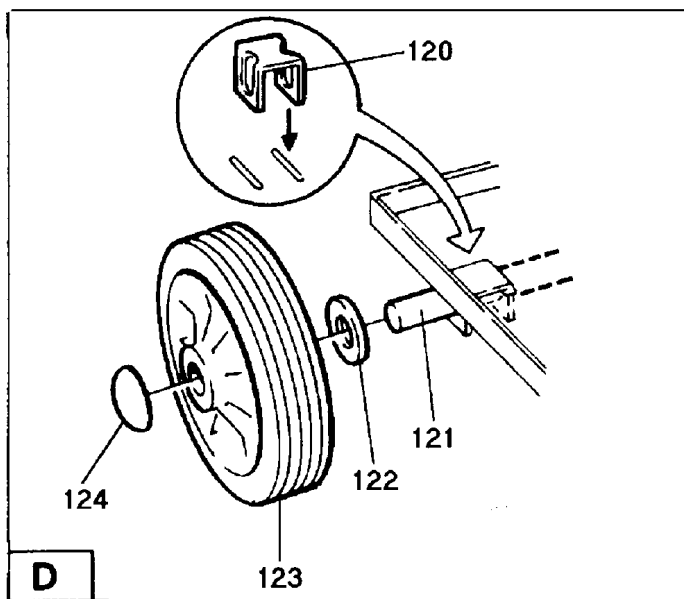
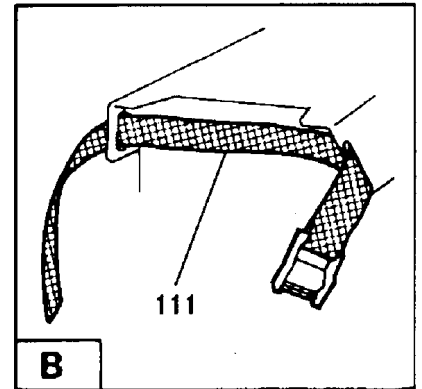
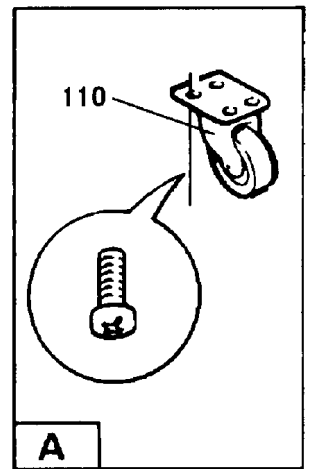
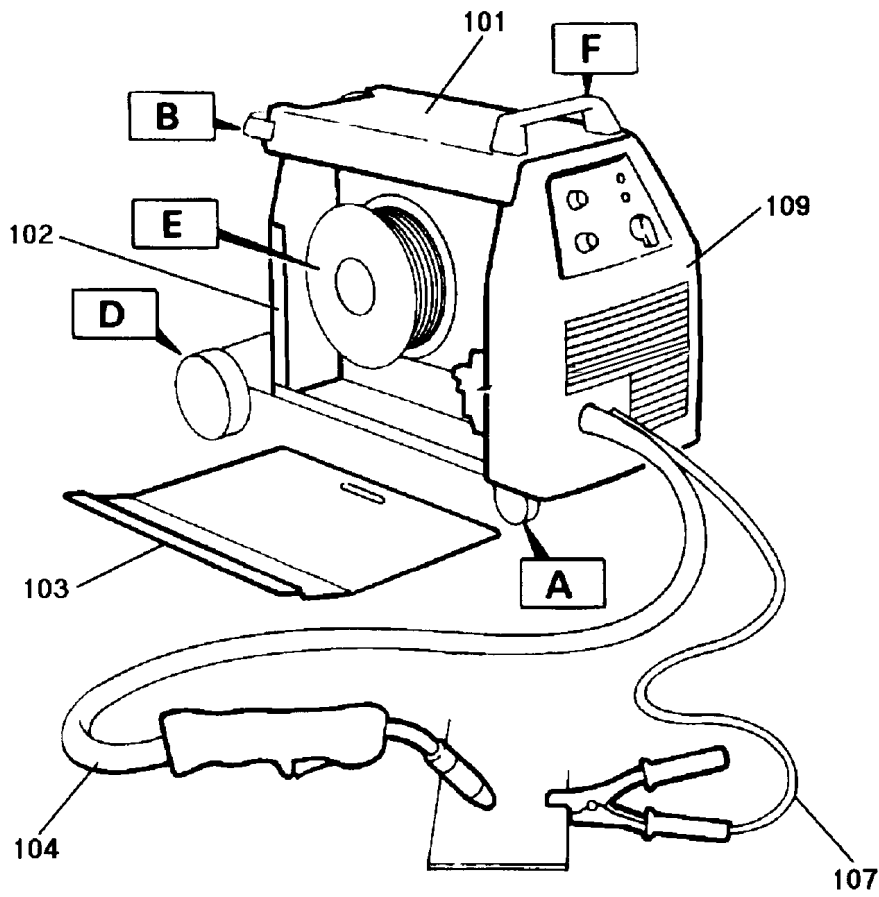

WIRE FEED UNIT

C = component designation in the circuit diagram

Item no.	Qty	Ordering no.	Denomination	Notes	C
-	-	455 890-890	Feed unit	Complete, contains items 301 - 333	
300	1	367 529-001	Pressure arm	Complete, contains items 301 - 305	
301	2	455 906-001	Spacer sleeve		
302	1	455 907-001	Pressure roller		
		466 262-001	Pressure roller *	Knurled	
303	1		Nut	SGA D8	
304	1		Holder		
305	1		Shaft		
306	1	455 896-001	Spring		
308	1	469 397-001	Drive unit		M1
309	1	2157 010-07	Locking washer	Included in item 308	
310	1	191 496-114	Key	Included in item 308	
311	1	466 074-001	Inlet nozzle		
312	1	367 528-001	Pin bolt		
313	1	368 749-880	Pressure transducer		
314	2	368 750-001	Insulating sleeve		
315	1	455 894-001	Insert tube		
316	1	455 885-001	Outlet nozzle		
317	1	455 882-001	Current sleeve		
318	1	455 883-001	Spacer sleeve	∅ 16/8.2x0.9	
319	1		Washer	∅ 16/8.4x1.5	
320	1		Screw	M8x20	
321	1	455 881-001	Protection plate		
322	1	2152 012-02	O-ring		
323	1	455 898-001	Screw	(M5x12)	
324	1		Screw	M4x12	
326	1	193 104-002	Washer	∅ 16/5x1	
327	1	367 556-001	Feed roller	For ∅ 0.6 - 0.8 mm Fe, Ss and cored wire	
	1	367 556-002	Feed roller *	For ∅ 0.8 - 1.0 mm Fe, Ss and cored wire	
	1	367 556-006	Feed roller *	Knurled, for ∅ 1.0 - 1.2 mm cored wire	
	1	367 556-004	Feed roller *	For ∅ 1.0 - 1.2 mm Al wire	
329	1	455 893-001	Shaft		
330	1	455 884-001	Gear housing		
331	3	2121 107-42	Screw	B12x16	
332	1	469 380-881	Capacitor	PME 0.1 µF 400 V, with cable lugs	C3
333	1	455 892-001	Spacer sleeve		

* = accessories

WIRE FEED UNIT

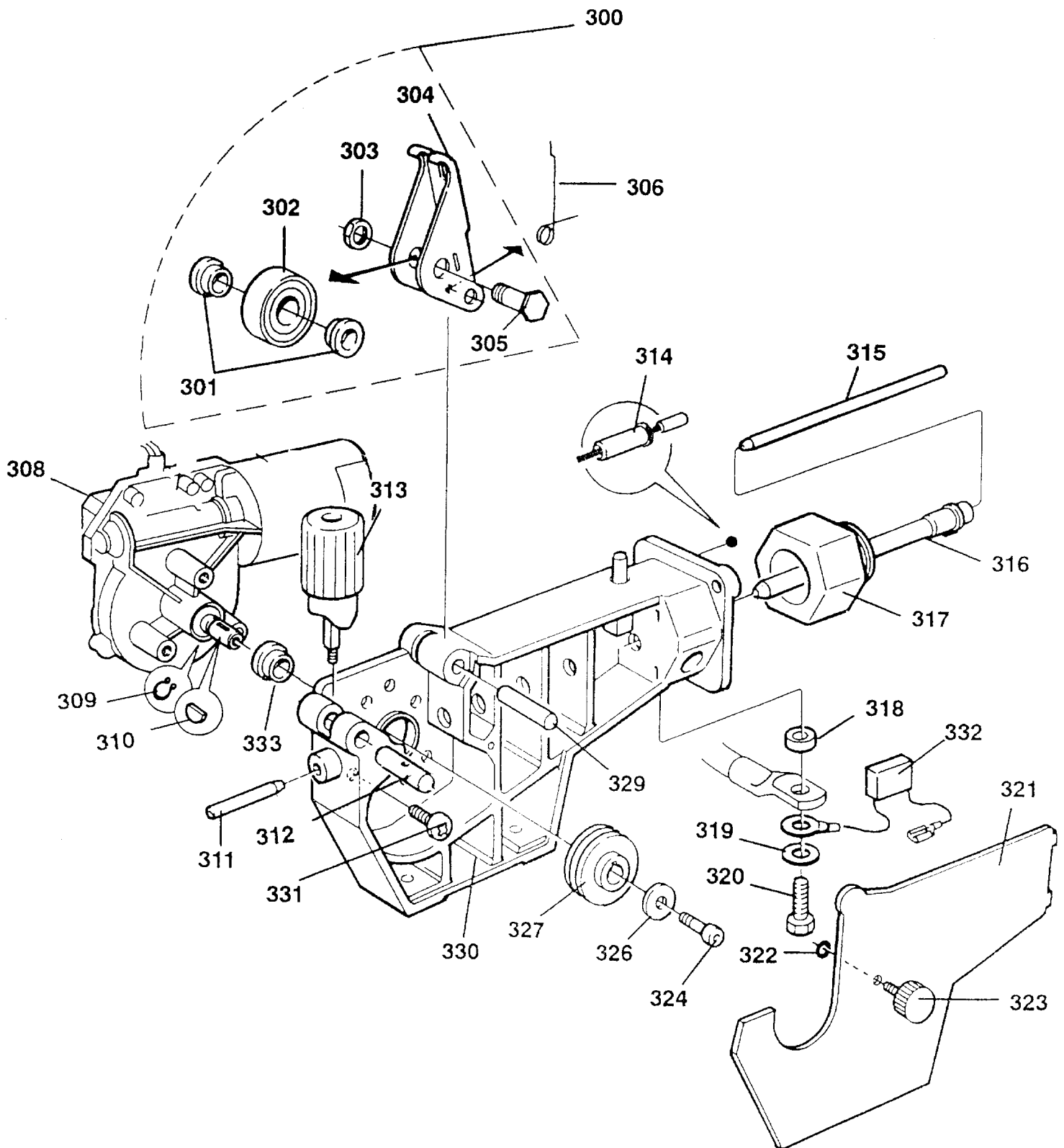

180= LKA180 240= LKA240

1ph= 1 phase 230V

rec= reconnectable 230/400V 400= 400 V mains supply voltage

C = component designation in the circuit diagram

Item no	Qty 180 1ph	Qty 180 400	Qty 180 rec	Qty 240 400	Qty 240 rec	Ordering no.	Denomination	Notes	C
201	1	1	1	1	1	193 054-002	Gas valve		YV1
202	1	-	-	-	-	469 659-001	Switch	With knob (item 227)	QF1
	-	1	-	-	-	469 472-001	Switch	Without knob (item 227)	QF1
	-	-	1	-	-	469 564-001	Switch	With knob (item 227)	QF1
	-	-	-	1	-	469 473-001	Switch	With knob (item 227)	QF1
	-	-	-	-	1	469 566-001	Switch	With knob (item 227)	QF1
203	1	-	-	-	-	193 297-101	Contacteur		KM1
	-	1	1	1	1	193 296-104	Contacteur		KM1
204	1	-	-	-	-	469 300-880	Inductor		L1
	-	1	1	1	1	469 295-880	Inductor		L1
205	1	-	1	-	1	469 563-001	Control transformer	Primary voltage 230/400 V	TC1
	-	1	-	1	-	469 470-001	Control transformer	Primary voltage 400 V	TC1
206	1	-	-	-	-	469 660-880	Main transformer	Thermal cutout ST1 included	TM1
	-	1	1	-	-	469 285-880	Main transformer	Thermal cutout ST1 included	TM1
	-	-	-	1	1	469 290-880	Main transformer	Thermal cutout ST1 included	TM1
207	1	-	-	-	-	2626 133-14	Mains cable	3 x 2.5 mm ² 2.5 meter	
	-	1	-	1	-	2626 134-05	Mains cable	4 x 1.5 mm ² 2.5 meter	
	-	-	1	-	1	192 106-117	Mains cable	4 x 2.5 mm ² 2.5 meter to be ordered per meter	
208	1	1	1	1	1	190 315-102	Gas hose	To be ordered per meter 1.5 meter as delivered	
209	1	-	-	-	-	469 662-880	Diode bridge		V1 - V6
	-	1	1	-	-	469 318-880	Diode bridge		V1 - V6
	-	-	-	1	1	469 346-880	Diode bridge		V1 - V6
210	1	1	1	1	1	469 380-880	Capacitor	Set of 2 capacitors, PME 0.1µF 400V, with cable lugs	C1 +C2
211	-	-	1	-	1	466 884-006	Terminal	6-pole	XT3
	-	-	1	-	1	469 569-001	Insulation	With text	
212	1	1	1	1	1	193 260-006	Connector	7-pole	XS3
213	1	1	1	1	1	193 260-151	Connector	3-pole, to R49 on AP1	
214	1	1	1	1	1	193 260-157	Connector	9-pole	XS1
215	1	1	1	1	1	193 260-153	Connector	5-pole, before ser.no. 618 ...	XS2
	1	1	1	1	1	193 260-150		2-pole, from ser.no. 618 ...	
	1	1	1	1	1	193 260-151		3-pole, from ser.no. 618 ...	
216	1	1	1	1	1	193 260-153	Connector	5-pole, to R50 on AP1	
217a	-	1	1	1	1	469 477-002	Cable inlet	With mains terminal	XT1
	1	-	-	-	-	469 477-001	Cable inlet		
217b	1	-	-	-	-	162 781-011	Mains terminal	Delivered as 12-pole, to be cut to 2-pole	XT1
	1	-	-	-	-	468 882-005	Insulation	With text	
218	6	6	6	6	6	192 562-105	Cage nut	M6	
219	3	3	3	3	3	469 381-001	Speednut		
220	1	-	-	-	-	321 229-003	Thermal cutout	Opens at 110°C	ST2
	-	1	1	1	1	320 918-001	Thermal cutout	Opens at 130°C	ST2
221	1	1	1	1	1	469 377-001	Connection block		XT2
222	1	1	1	1	1	469 378-001	Insulation		
223	1	1	1	1	1	469 379-001	Bus bar		
224	1	1	1	1	1	486 159-880	Circuit board	Before ser.no. 618	AP1
	1	1	1	1	1	486 159-882	Circuit board	From ser.no. 618	AP1
225	1	1	1	1	1	193 759-002	Light-emitting diode	Yellow	V7
226	1	1	1	1	1	193 759-001	Indicating lamp	White, 28 V	HL1
227	-	1	-	-	-	366 296-001	Knob		
	1	-	1	1	1		Knob	Included in item 202	
228	2	2	2	2	2	191 510-104	Knob		
229	1	1	1	-	-	469 365-001	Panel	With text	
	-	-	-	1	1	469 366-001	Panel	With text	
230	1	-	-	1	1	469 479-001	Fan	24 V DC	EV1
231	1	-	-	-	-	467 169-001	Resistor		R1
232	1	-	-	-	-	369 864-881	Resistor	5.6 kΩ 5 W	R2

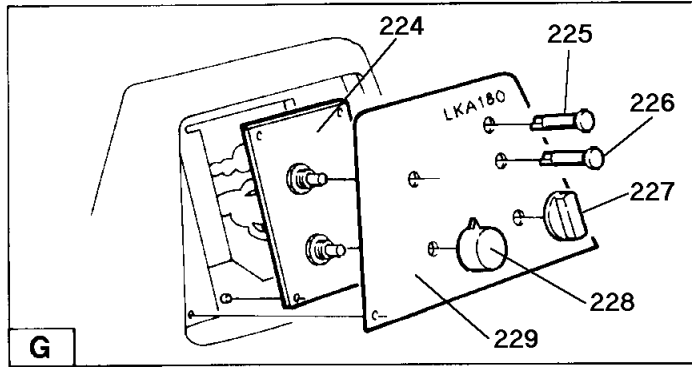
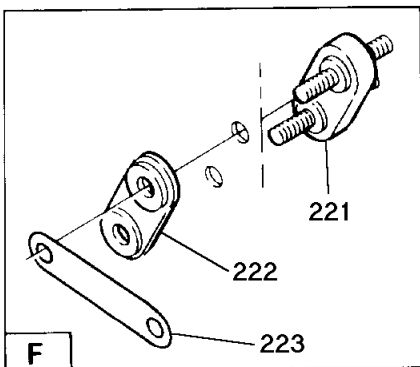
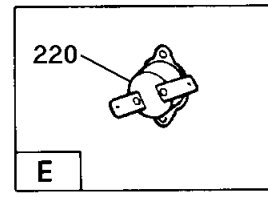
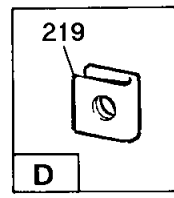
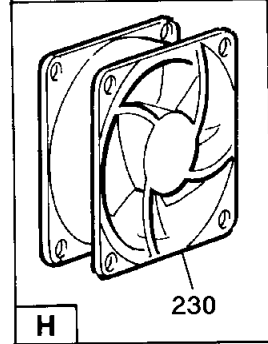
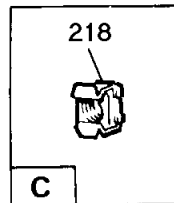
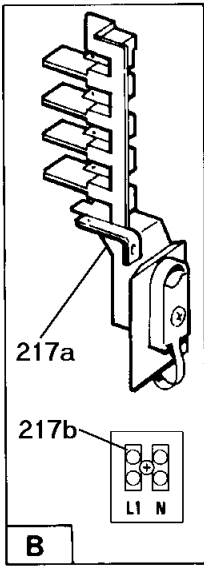
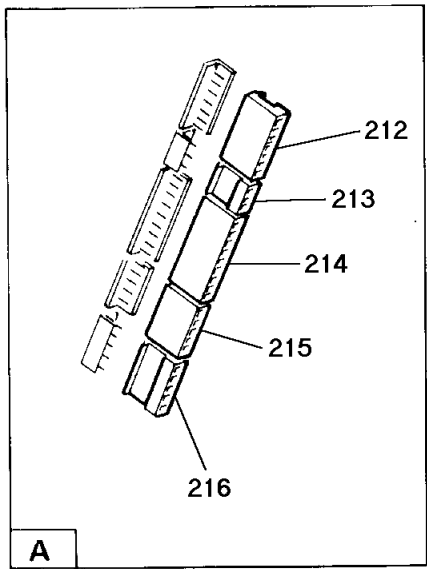
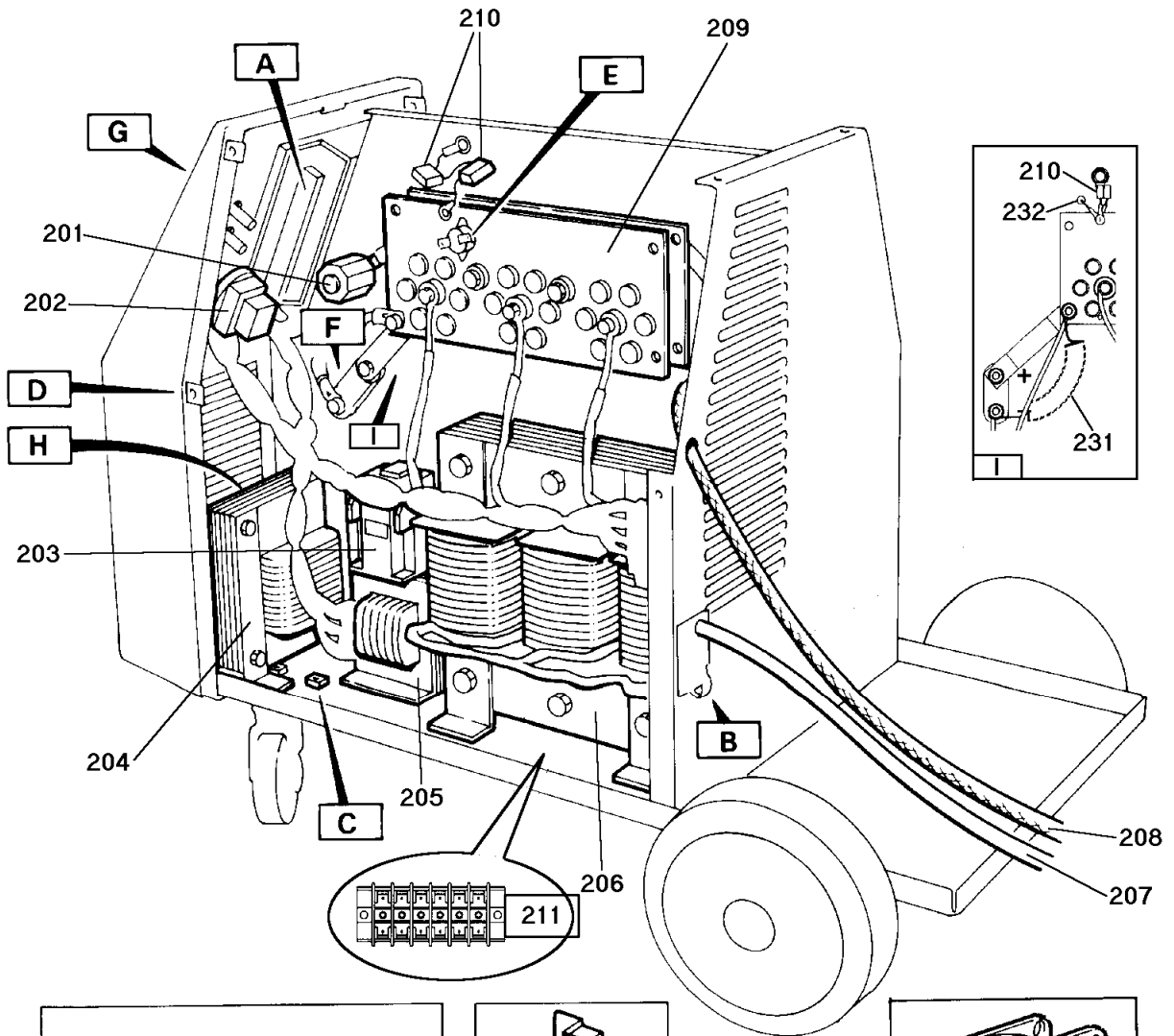

AP0218

ESAB subsidiaries and representative offices

Europe

AUSTRIA

ESAB Ges.m.b.H
Vienna-Liesing
Tel: +43 1 888 25 11
Fax: +43 1 888 25 11 85

BELGIUM

S.A. ESAB N.V.
Brussels
Tel: +32 2 745 11 00
Fax: +32 2 726 80 05

THE CZECH REPUBLIC

ESAB VAMBERK s.r.o.
Prague
Tel: +420 2 819 40 885
Fax: +420 2 819 40 120

DENMARK

Aktieselskabet ESAB
Copenhagen-Valby
Tel: +45 36 30 01 11
Fax: +45 36 30 40 03

FINLAND

ESAB Oy
Helsinki
Tel: +358 9 547 761
Fax: +358 9 547 77 71

FRANCE

ESAB France S.A.
Cergy Pontoise
Tel: +33 1 30 75 55 00
Fax: +33 1 30 75 55 24

GERMANY

ESAB GmbH
Solingen
Tel: +49 212 298 0
Fax: +49 212 298 204

GREAT BRITAIN

ESAB Group (UK) Ltd
Waltham Cross
Tel: +44 1992 76 85 15
Fax: +44 1992 71 58 03

ESAB Automation Ltd

Andover
Tel: +44 1264 33 22 33
Fax: +44 1264 33 20 74

HUNGARY

ESAB Kft
Budapest
Tel: +36 1 20 44 182
Fax: +36 1 20 44 186

ITALY

ESAB Saldatura S.p.A.
Mesero (Mi)
Tel: +39 02 97 96 81
Fax: +39 02 97 28 91 81

THE NETHERLANDS

ESAB Nederland B.V.
Utrecht
Tel: +31 30 248 59 22
Fax: +31 30 248 52 60

NORWAY

AS ESAB
Larvik
Tel: +47 33 12 10 00
Fax: +47 33 11 52 03

POLAND

ESAB Sp. z o.o.
Katowice
Tel: +48 32 35 111 05
Fax: +48 32 35 111 20

PORTUGAL

ESAB Lda
Lisbon
Tel: +351 1 837 1527
Fax: +351 1 859 1277

SLOVAKIA

ESAB Slovakia s.r.o.
Bratislava
Tel: +421 7 44 88 24 26
Fax: +421 7 44 88 87 41

SPAIN

ESAB Ibérica S.A.
Alcobendas (Madrid)
Tel: +34 91 623 11 00
Fax: +34 91 661 51 83

SWEDEN

ESAB Sverige AB
Gothenburg
Tel: +46 31 50 95 00
Fax: +46 31 50 92 22

ESAB International AB

Gothenburg
Tel: +46 31 50 90 00
Fax: +46 31 50 93 60

SWITZERLAND

ESAB AG
Dietikon
Tel: +41 1 741 25 25
Fax: +41 1 740 30 55

North and South America

ARGENTINA

CONARCO
Buenos Aires
Tel: +54 11 4 753 4039
Fax: +54 11 4 753 6313

BRAZIL

ESAB S.A.
Contagem-MG
Tel: +55 31 3369 4333
Fax: +55 31 3369 4440

CANADA

ESAB Group Canada Inc.
Mississauga, Ontario
Tel: +1 905 670 02 20
Fax: +1 905 670 48 79

MEXICO

ESAB Mexico S.A.
Monterrey
Tel: +52 8 350 5959
Fax: +52 8 350 7554

USA

ESAB Welding & Cutting Products
Florence, SC
Tel: +1 843 669 44 11
Fax: +1 843 664 44 58

Asia/Pacific

CHINA

Shanghai ESAB A/P
Shanghai
Tel: +86 21 6539 7124
Fax: +86 21 6543 6622

INDIA

ESAB India Ltd
Calcutta
Tel: +91 33 478 45 17
Fax: +91 33 468 18 80

INDONESIA

P.T. Esabindo Pratama
Jakarta
Tel: +62 21 460 01 88
Fax: +62 21 461 29 29

MALAYSIA

ESAB (Malaysia) Snd Bhd
Selangor
Tel: +60 3 703 36 15
Fax: +60 3 703 35 52

SINGAPORE

ESAB Singapore Pte Ltd
Singapore
Tel: +65 861 43 22
Fax: +65 861 31 95

ESAB Asia/Pacific Pte Ltd

Singapore
Tel: +65 861 74 42
Fax: +65 863 08 39

SOUTH KOREA

ESAB SeAH Corporation
Kyung-Nam
Tel: +82 551 289 81 11
Fax: +82 551 289 88 63

UNITED ARAB EMIRATES

ESAB Middle East
Dubai
Tel: +971 4 338 88 29
Fax: +971 4 338 87 29

Representative offices

BULGARIA

ESAB Representative Office
Sofia
Tel/Fax: +359 2 974 42 88

EGYPT

ESAB Egypt
Dokki-Cairo
Tel: +20 2 390 96 69
Fax: +20 2 393 32 13

ROMANIA

ESAB Representative Office
Bucharest
Tel/Fax: +40 1 322 36 74

RUSSIA-CIS

ESAB Representative Office
Moscow
Tel: +7 095 937 98 20
Fax: +7 095 937 95 80

ESAB Representative Office

St Petersburg
Tel: +7 812 325 43 62
Fax: +7 812 325 66 85

Distributors

For addresses and phone numbers to our distributors in other countries, please visit our home page

www.esab.com



ESAB AB
SE-695 81 LAXÅ
SWEDEN
Phone +46 584 81 000



www.esab.com